



www.hth.info



FDC

Fire damper

Fire protection

Installation and operation manual

Scan for
Product catalog



Scan for
Declaration of
performance



Version 1.0.0

Issue Date: 20.03.2026.

Read this before using this manual

This installation and operating manual is designed to assist operational or service personnel in properly installing and utilizing the Klimaoprema products, ensuring safe and effective use. This manual is intended for installation companies, in-house technicians, technical personnel, trained individuals, and certified electricians. It is crucial for these individuals to read and fully comprehend this manual before commencing any work. Adhering to the safety guidelines and all instructions within this manual is fundamental for safe operations.

Local health and safety regulations, along with general safety standards, are also applicable.

Upon commissioning of the system, this manual should be provided to the system owner, who must retain it with the system documentation. The manual should be stored in an easily accessible location at all times.

The illustrations in this manual are primarily for informational purposes and may not accurately represent the actual design.

Limitation of Liability

The information provided in this manual has been compiled in accordance with relevant standards and guidelines, reflecting the current state of technology and our extensive expertise and experience.

The manufacturer disclaims any liability for damages arising from:

- Non-compliance with this manual
- Operation or handling by untrained personnel
- Technical alterations
- Improper use
- Unauthorized modifications
- Use of non-approved replacement components

The delivery contents may differ from what is described in this manual due to customized designs, extra order options, or recent technical modifications.

The responsibilities outlined in the order, along with the general terms and conditions, the manufacturer's delivery terms, and the applicable legal regulations at the time the contract is signed, will be in effect.

We reserve the right to implement technical modifications.

Copyright

This document is protected by copyright. Any unauthorized use may constitute a copyright infringement, and the infringer will be liable for any resulting damages.

Qualified Personnel

Warning!

Risk of Injury from Insufficiently Qualified Individuals! Improper use may lead to significant injury or property damage. Only trained specialists should perform this work.

Personnel Requirements:

Skilled Qualified Electrician:

A skilled qualified electrician is an individual with adequate

professional or technical training, knowledge, and hands-on experience necessary to work on electrical systems. They should be able to identify potential hazards associated with their tasks and recognize and mitigate any associated risks.

Specialist Personnel:

Specialist personnel possess sufficient professional or technical training, knowledge, and experience to fulfill their assigned responsibilities. They should be aware of potential hazards related to their work and capable of recognizing and avoiding any risks involved.

SAFETY!

Proper Use

The fire damper functions as an automatic shut-off device to prevent the spread of fire and smoke through ductwork. It is suitable for both supply and exhaust air in HVAC systems. The fire damper can be utilized in potentially explosive environments if the appropriate special accessories are employed and the product displays the CE conformity marking in accordance with Directive 94/9/EC. Fire dampers intended for such atmospheres are labeled for the zones for which they have been certified. The operation of the fire dampers is permitted only in accordance with installation regulations and the technical specifications provided in this installation and operating manual. Altering the fire damper or using unapproved replacement parts is strictly prohibited.

CAUTION!

Risk of Injury from Sharp Edges, Corners, and Thin Sheet Metal Parts! Sharp edges, pointed corners, and thin metal components can lead to cuts or abrasions. Exercise caution when performing any work. Always wear protective gloves, safety footwear, and a hard hat.

DANGER!

Risk of Electric Shock! Do Not Touch Live Components! Electrical equipment carries hazardous voltage.

Only qualified electricians are permitted to work on the electrical system. Always turn off the power supply before servicing any electrical equipment.

WARNING!

Risk of Danger from Improper Use!

Incorrect use of the fire damper can create hazardous situations.

Never use the fire damper:

- Without specially approved attachments in potentially explosive environments
- As a smoke control damper
- Outdoors without adequate protection from weather conditions
- In environments where chemical reactions, whether intended or unintended, could damage the fire damper or cause corrosion.

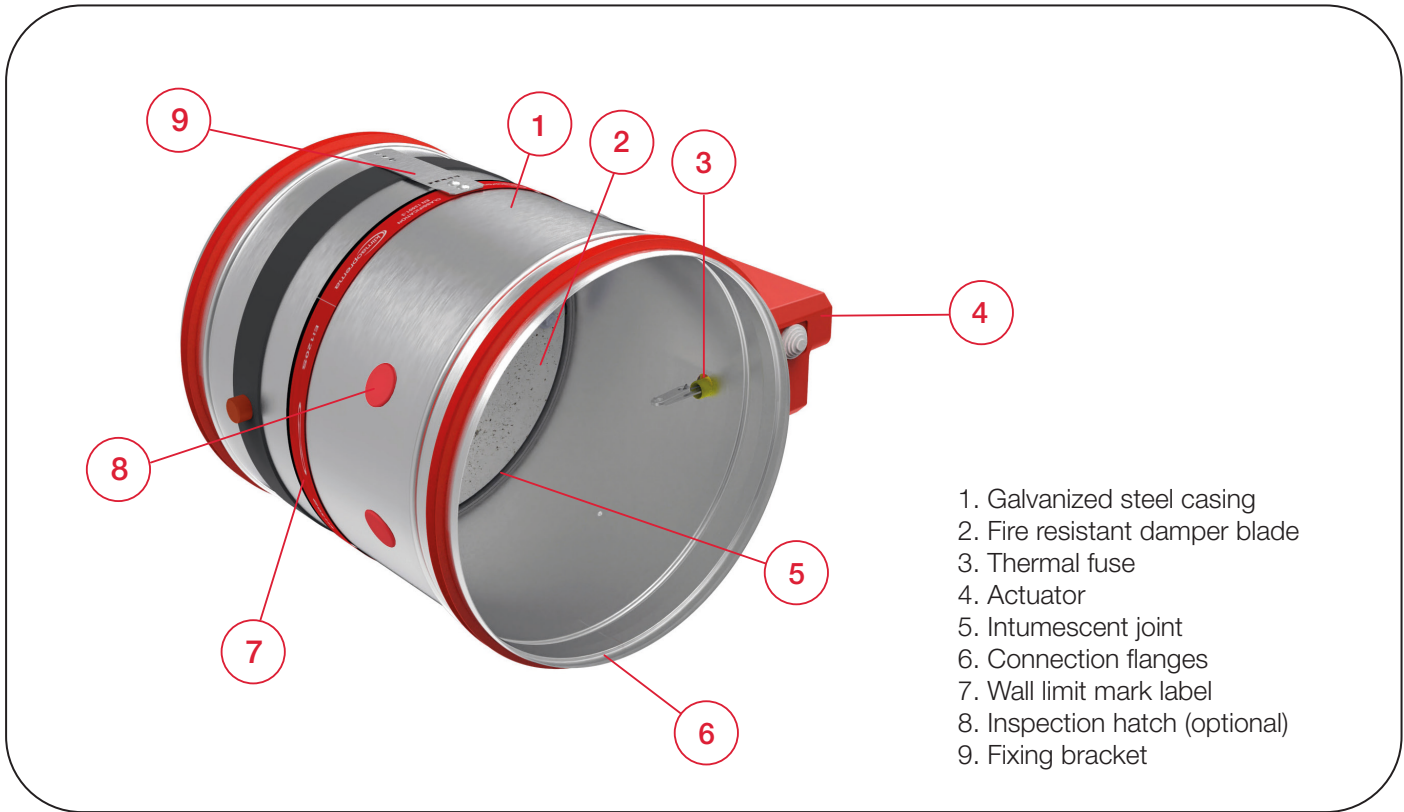

PRODUCT OVERVIEW

Fire dampers FDC are used for prevention of fire spread through the ventilation ducts and between fire sections. Fire dampers consist of steel sheet casing, calcium silicate damper blade, damper blade mechanism outside of the airflow and a manual, electromagnetic or electric actuator.

Fire damper casing is made out of galvanized steel sheet. Variants produced from stainless steel and powder coated steel are also available. Calcium silicate blade is equipped with brass bearings and seals made out of polyurethane and elastomer rubber.

All fire dampers are tested according to the EN 1751 for airtightness and retain class 3 leakage on the closed damper blade and class C on the casing air leakage.

Fire dampers FDC25 are produced from d100 up to size d315 and have 25 mm thick damper blade. Fire dampers FDC40 are produced in sizes from d355 till d800 and have 40 mm thick damper blade.

FDC25 fire dampers are equipped with R25 manual mechanism and FDC40 fire dampers are equipped with R40 manual mechanism.

Manual spring return mechanism is equipped with thermal fuse that is triggered automatically when the temperature inside the duct reaches 72 °C. It can also be activated manually by the push of the button on the mechanism. Additional equipment for manual mechanism include end contact switches for damper position signalling.

Electromagnetic actuators feature spring return mechanism with electromagnet for remote activation. Additional equipment for electromagnetic mechanism include end contact switches for damper position signalling. Rearming of the electromagnetic actuator is manual.

Fire dampers with electric actuators are equipped with Belimo actuator drives in 24 V or 230 V versions. Activation of fire dampers equipped with electric drives can be via 72 °C or 95 °C thermal fuse or remotely via control signal. Rearming of the electric fire damper can also be done remotely via control signal. All electric actuators are equipped with end switches for position signalling.

ATEX rated versions of fire dampers can be delivered with Schischek 24 V / 230 V electric actuators that are rated for installation in explosive atmosphere areas.

All fire dampers are tested according to the EN 1751 for airtightness and retain class 3 leakage on the closed damper blade and class C on the casing air leakage.

1 CLASS C EN1751

  **USER MANUALS**

www.hth.info 

2 SERIAL NUMBER:	201623500700001	16
3 PRODUCTION DATE	11.03.2022	
4 TYPE:	FDC25 – d125 – R	
5 DIMENSION:	d125	17 LOCATION:
6 ACT. MECHANISM:	R	9 IP PROTECTION:
7 NOMINAL VOLTAGE:	–	10 FREE SPACE m ² :
8 SIGNALISATION	No	11 THERMAL FUSE:
		72°C

 **EN15650:2010** **12**

1812
17
1812 – CPR – 1161 **13**

13 For fire classification of product
consult declaration of performance.
DOP 711 XXX **14**

14 EI60/90/120 (Ve Ho i < – > o)S 500Pa **14**

19 **PRODUCT MUST BE INSTALLED BY INSTRUCTIONS SUPPLIED BY MANUFACTURER**

 **15**

201623500700001

Product label

- 1 - Casing air leakage classification
- 2 - Serial number
- 3 - Production date
- 4 - Type
- 5 - Dimension of the fire damper
- 6 - Mechanism type
- 7 - Nominal voltage
- 8 - Signalisation (end contacts)
- 9 - IP protection
- 10 - Free space
- 11 - Thermal fuse temperature
- 12 - Number of the European standard and year of its publication
- 13 - Declaration of performance
- 14 - Classification according to EN 13501-3
- 15 - Barcode
- 16 - QR code link to user manual
- 17 - Location-if specified
- 18 - CE- Classification
- 19 - Notified body Products Regulation

MODELS

Casings

FDC25

Cylindrical fire damper with 25 mm damper blade and fire classification up to EI120S. Sizes range from d100 till d315.

FDC40

Cylindrical fire damper with 40 mm damper blade and fire classification up to EI120S. Sizes range from d355 till d800.

FDC25 - APP

Cylindrical fire damper with integrated Applique installation frame with 25 mm damper blade and fire classification up to EI90S.

Sizes range from d100 till d315.

FDC25 - MF1/MF2

Cylindrical fire damper with integrated MF1 installation frame with 25 mm damper blade and fire classification up to EI60S.

Sizes range from d100 till d315.

FDC40 - MF2

Fire damper with integrated MF2 installation frame with 40 mm damper blade and fire classification up to EI90S. Sizes range from d355 till d800.

Actuators

R (R-S)

Manual operating mechanism, optionally with end switches (R-S). In case of fire, the fire damper closes automatically. Damper closing can be initiated either by thermal fuse melting, or by manual activation on the operating mechanism. Upon closure, damper blade is locked in closed position and can only be opened manually. Thermal fuse melting point is 72 °C.

EMS-S

Electromagnetic operating mechanism, comes with end switches as standard. In case of fire, the fire damper closes automatically. Damper closing can be initiated either by thermal fuse melting or remotely by triggering the electromagnet. Electromagnet is constantly under power and activates closing of the damper blade in case the power cuts out. Upon closure, damper blade is locked in closed position and can only be opened manually. Thermal fuse melting point is 72 °C.

M230-S/M230-S-ST

Belimo 230 V electro motor operating mechanism, comes with integrated end switches. In case of fire, the fire damper closes automatically.

Damper closing can be initiated either by thermoelectric release device or remotely by triggering the electro motor. Upon closure, damper blade is locked in closed position and can be opened by sending a signal to electro motor. Standard thermoelectric release point is 72 °C, optional 95 °C.

Product specifications

Nominal sizes FDC	100 - 800 [mm]
Casing length	380 mm
Temperature range	-20 °C ... 50 °C
Release temperature	72 °C (standard) or 95 °C (optional with electric actuator)
	Electric drive up to 12m/s
Volume flow rate range	EMS up to 10m/s
	Manual drive
Differential pressure range	up to 1000 Pa
Casing air leakage	Class C, EN 1751
Closed blade air leakage	Class 3, EN 1751
Upstream velocity	< 12 m/s
EC conformity	EN 13501-3, EN 1366-2, EN 15650, EN 1751, CPR no.305/2011
Declaration of performance	DoP 711 XXX

M230-S-ST actuator is additionally equipped with connection plug for easy connection with power supply and communication modules.

M24-S/ M24-S-ST

Belimo 24 V electro motor operating mechanism, comes with integrated end switches. In case of fire, the fire damper closes automatically.

Damper closing can be initiated either by thermoelectric release device or remotely by triggering the electro motor. Upon closure, damper blade is locked in closed position and can be opened by sending a signal to electro motor. Standard thermoelectric release point is 72 °C, optional 95 °C. M24-S-ST actuator is additionally equipped with connection plug for easy connection with power supply and communication modules.

EX

ATEX rated fire dampers are equipped with Schischek ExMax-5.10-BF actuators, ExPro-TT thermal switches and ExBox-BF plenum boxes.

Optional casing can be produced in AISI 316 stainless steel.

FDC25/FDC40 - R (manual mechanism)

- Automatic closure when the temperature in the duct exceeds 72 °C
- Manual rearming
- Manual unlocking possible for periodical test of fire damper
- Optional with end position switches (-R-S)
- FDC25 fire dampers are equipped with R25 manual mechanism
- FDC40 fire dampers are equipped with R40 manual mechanism



Product	A [mm]	C [mm]	D [mm]	E [mm]
FDC 25	55	150	105	150
FDC 40	55	200	105	200

FDC25-R25

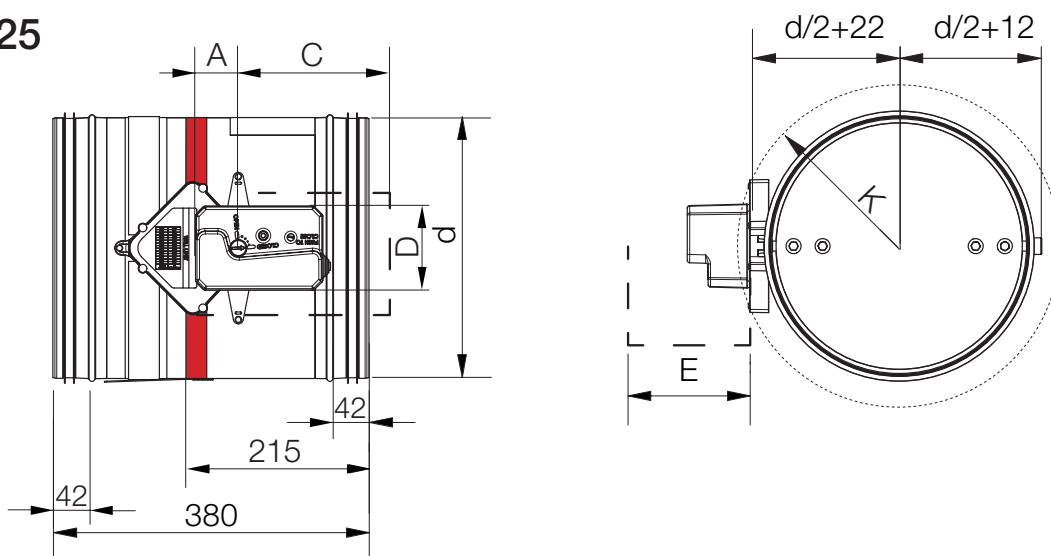

FDC40-R40

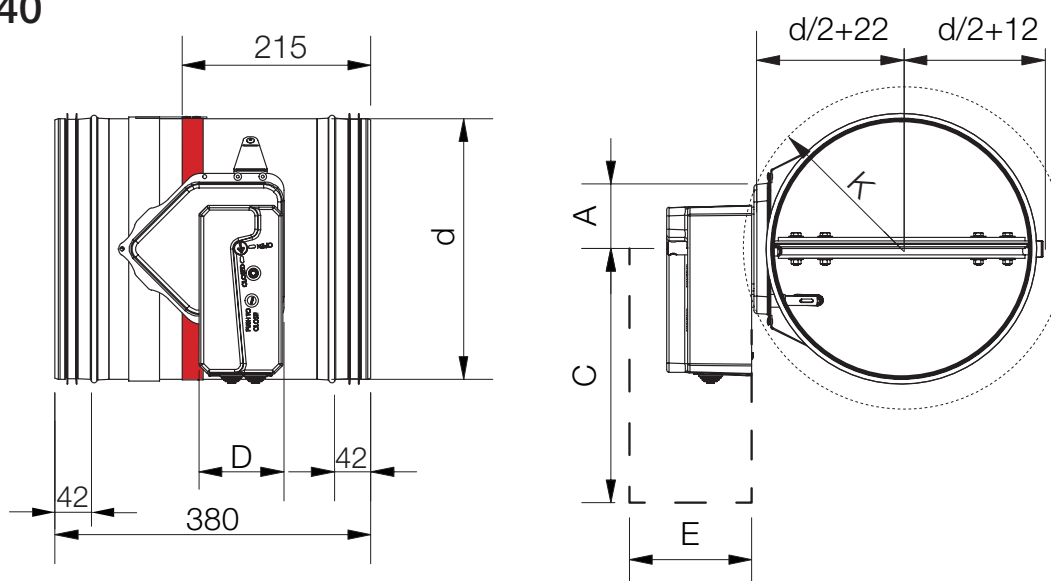

	FDC25-R						FDC40-R							
Ød [mm]	100	125	160	200	250	315	355	400	450	500	560	630	710	800
Weight [kg]	3,8	4,2	4,7	5,4	6,3	7,7	11,9	13,5	15,4	17,5	20,4	23,6	27,7	33,7
K [mm]	120	128	140	155	176	204	221	242	265	289	317	351	389	433

FD25/FD40 - EMS (solenoid actuator)

- Electromagnetic actuator with integrated limit switches and thermal fuse release mechanism (72 °C)
- Manual rearming
- Remote closing with electromagnetic actuator
- Manual closing possible
- EMS - solenoid actuator is constantly under power. Actuating mechanism is tripped when the power is interrupted, or thermal fuse is melted.

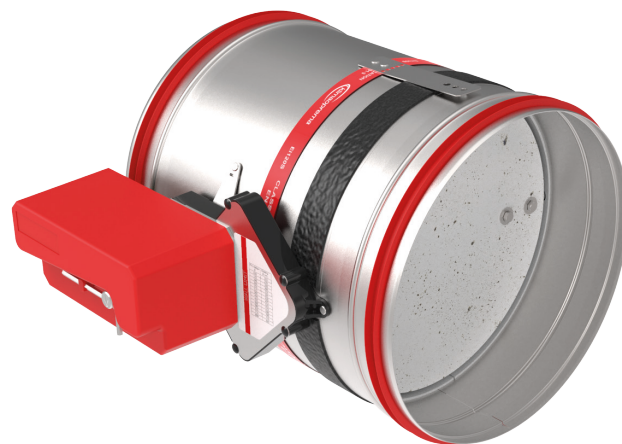

Product	A [mm]	C [mm]	D [mm]	E [mm]
FDC 25	55	150	105	150
FDC 40	55	200	105	200

FDC25-R25

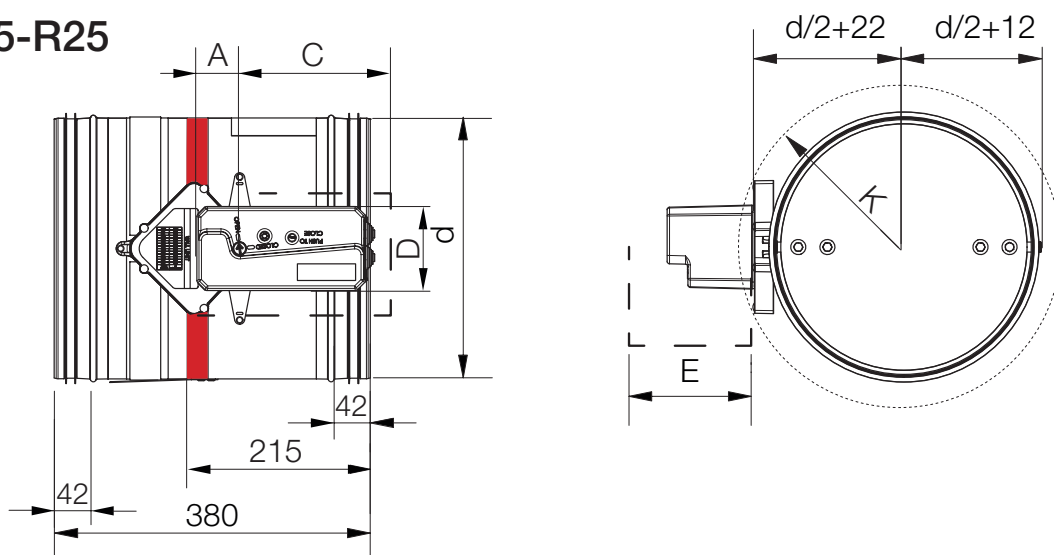

FDC40-R40

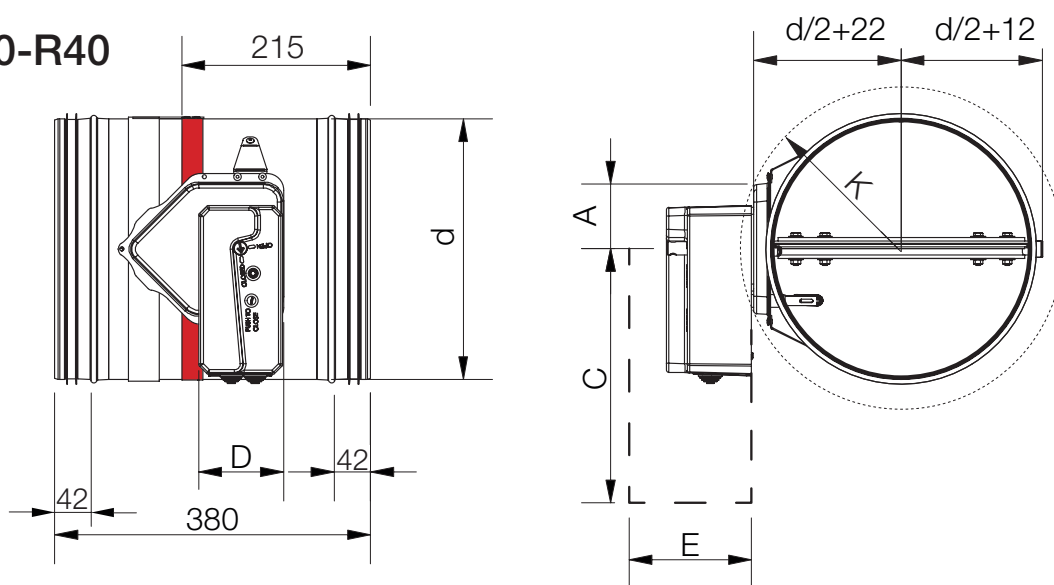

	FDC25-EMS							FDC40-EMS						
Ød [mm]	100	125	160	200	250	315	355	400	450	500	560	630	710	800
Weight [kg]	5,3	5,7	6,2	6,9	7,8	9,2	12,2	13,8	15,7	17,8	20,7	23,9	28	34
K [mm]	120	128	140	155	176	204	221	242	265	289	317	351	389	433

* The images shown are for illustration purposes only and may not be an exact representation of the product.

FDC25/FDC40 - M (electric actuator)

- Thermoelectric release device (72 °C) with electric actuator and return spring
- Integrated end switches
- Fully automatic operation
- Optional 95 °C thermoelectric release device for warm air installations



Product	A [mm]	C [mm]	D [mm]	E [mm]
BFL (M)	25	200	90	120
BFN (M)	25	225	100	120
BF (M)*	50	250	100	120

FDC25-R25

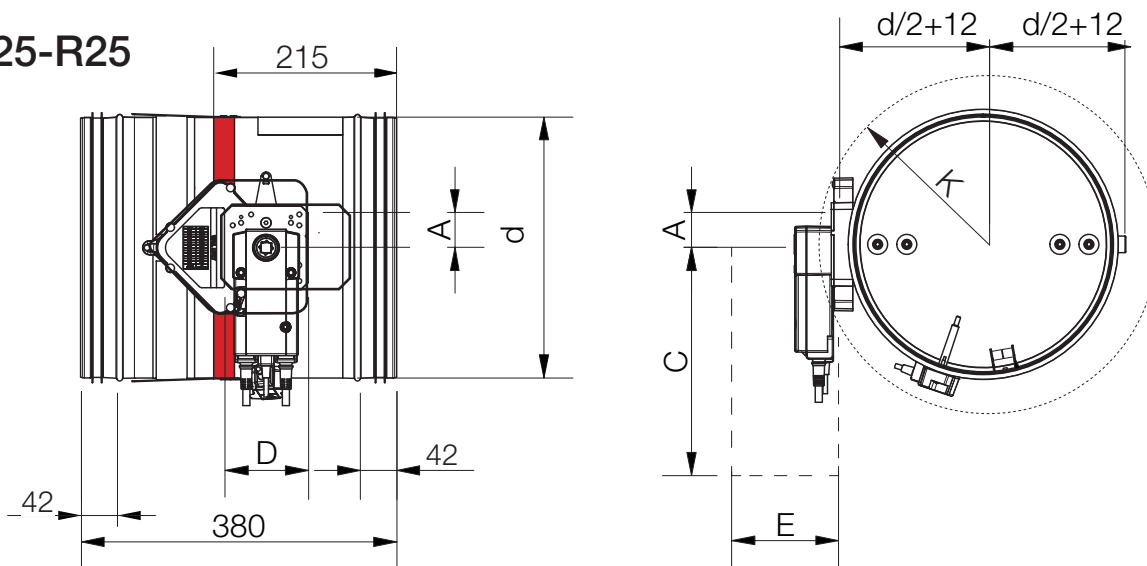

FDC40-R40

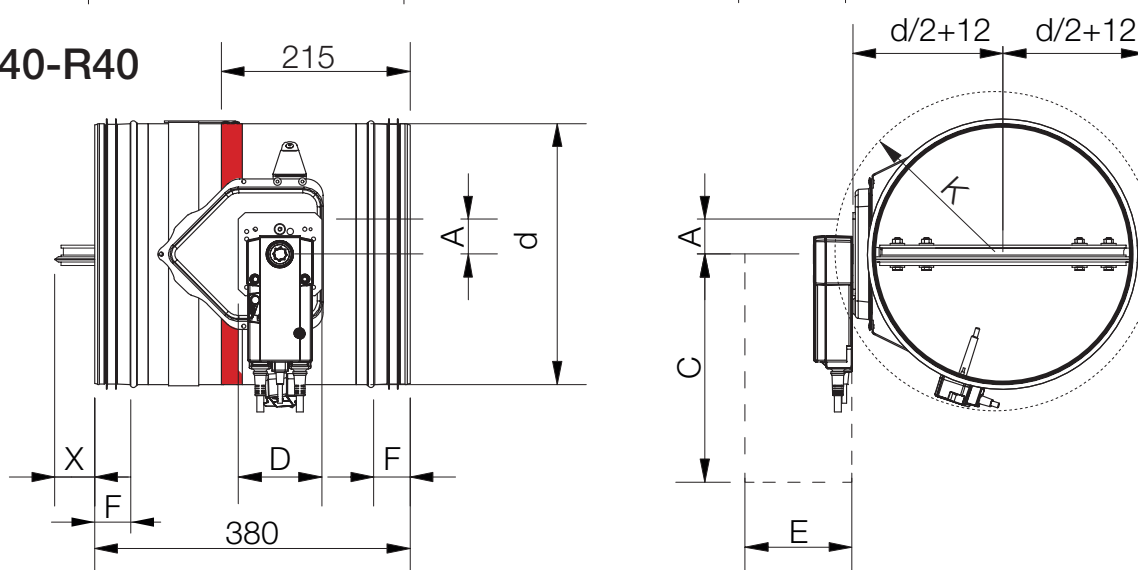

	FDC25-M							FDC40-M						
Ød [mm]	100	125	160	200	250	315	355	400	450	500	560	630	710	800
Weight [kg]	4,5	4,9	5,4	6,1	7	8,4	11,7	13,3	15,2	17,3	20,2	23,4	29,1	35,1
Actuator type	BFL	BFL	BFL	BFL	BFL	BFL	BFN	BFN	BFN	BFN	BFN	BFN	BFN	BF
K [mm]	120	128	140	155	176	204	221	242	265	289	317	351	389	433

FDC25/FDC40 - EX (electric actuator)

- Thermoelectric release device (72 °C) with electric actuator and return spring
- Integrated end switches
- Fully automatic operation
- The EX version of the damper comes with:
 - 1) Safety temperature trigger Schischek ExPro-TT
 - 2) Electric actuator Schischek ExMax-5.10-BF
 - 3) Terminal box Schischek ExBox-BF



Ex classification of product:

Ex II 2G Ex h IIC T6 Gb

Ex II 2D Ex h IIIC T80°C Db

For more information about Ex classification, visit website: [ATEX classification](#)

Type Examination Certificate Number: FIDI 21 ATEX D059. Equipment complies with the essential health and safety requirements relating to the design and construction of equipment intended to use in potentially explosive atmospheres given in annex VIII of the directive ATEX 2014/34/EU.

Please consult latest Declaration of conformity on our website: www.klimaprema.com/FD-EX Doc

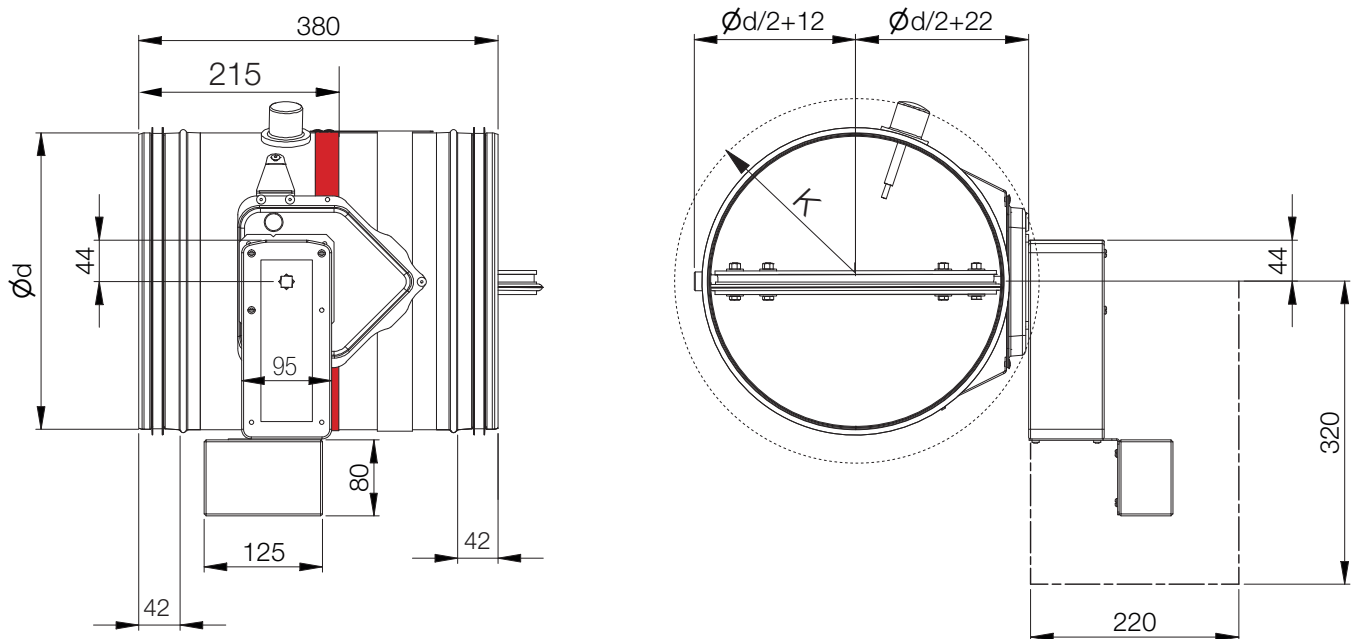

	FDC25-EX							FDC40-EX							
Ød [mm]	100	125	160	200	250	315	355	400	450	500	560	630	710	800	
Weight [kg]	7,9	8,3	8,8	9,5	10,4	11,8	14,8	16,4	18,3	20,4	23,1	26,5	30,6	36,6	
Actuator type	ATEX rated Schischek 24/230 V electric actuator+ExPro-TT+ExBox-BF														
K [mm]	120	128	140	155	176	204	221	242	265	289	317	351	389	433	

* The images shown are for illustration purposes only and may not be an exact representation of the product.

FDC25 - APP

Applique installation frame

- Applique kit is an installation subframe for quick and easy installation in rigid and flexible walls
- Made out of calcium silicate boards
- Quick wall mounting with screws
- Factory assembled to the fire damper



FD25-APP-R

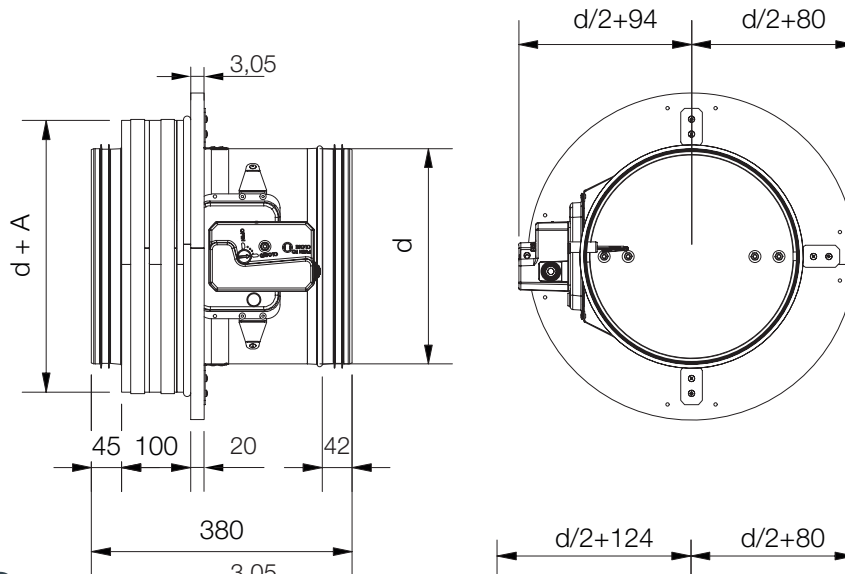

FD25-APP-EMS

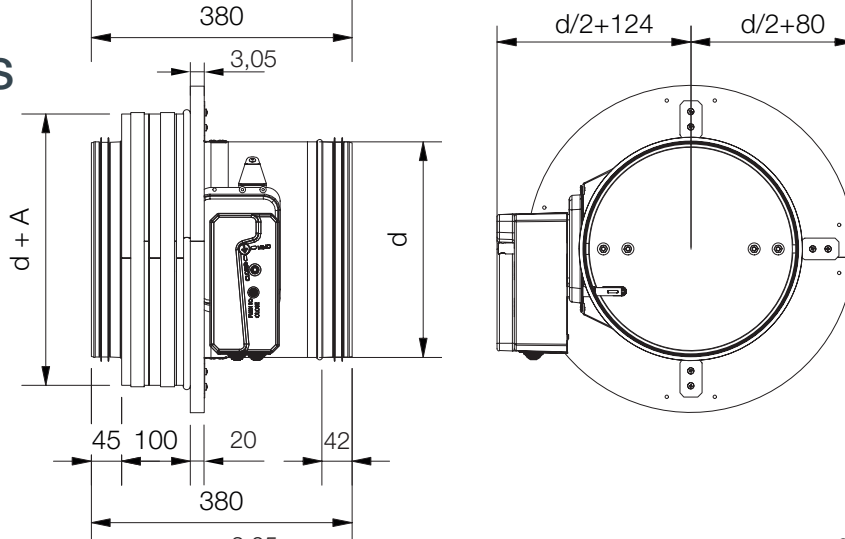

FD25-APP-M

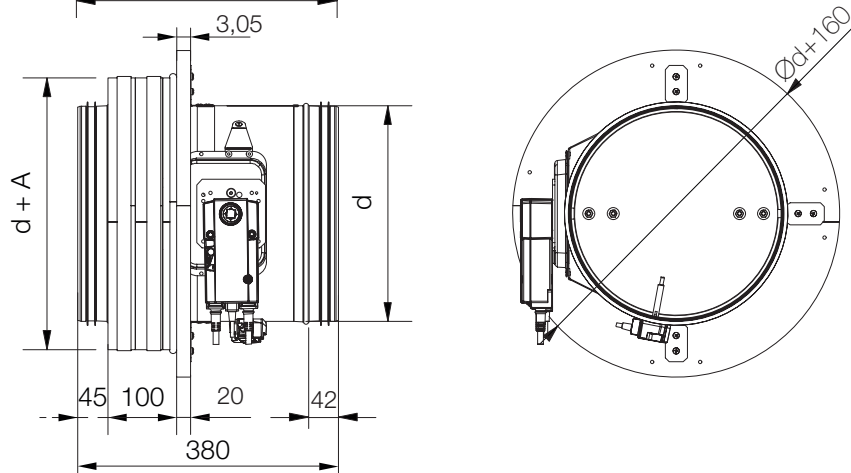

	FDC25-APP-R						FDC25-APP-EMS						FDC25-APP-M					
Ød [mm]	100	125	160	200	250	315	100	125	160	200	250	315	100	125	160	200	250	315
Weight [kg]	6,2	6,7	7,8	8,5	10,1	12,3	7,7	8,2	9,3	10	11,6	13,8	6,9	7,4	8,5	9,2	10,8	13

FDC25

MF1 installation frame

- MF1 is an installation frame for quick and easy installation in rigid and flexible walls
- Made out of calcium silicate boards
- Quick wall mounting with screws
- Factory assembled to the fire damper



FDC25-MF1-R

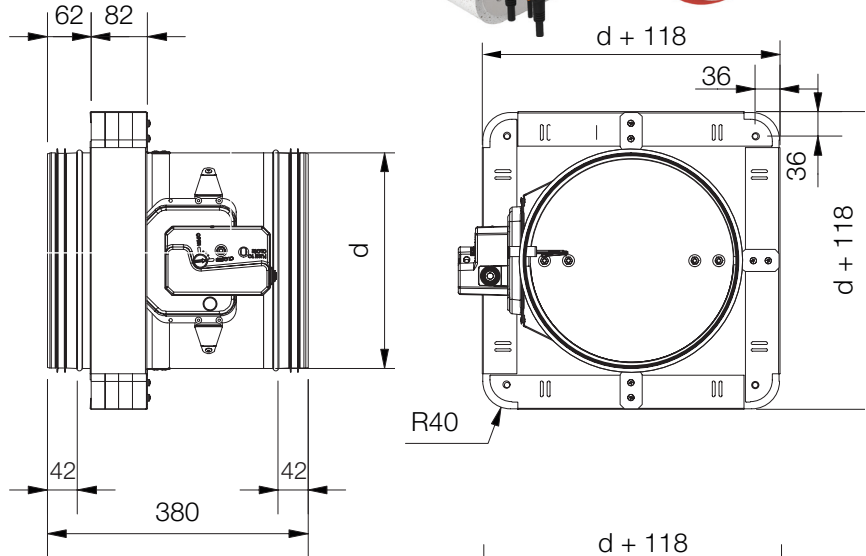

FDC25-MF1-EMS

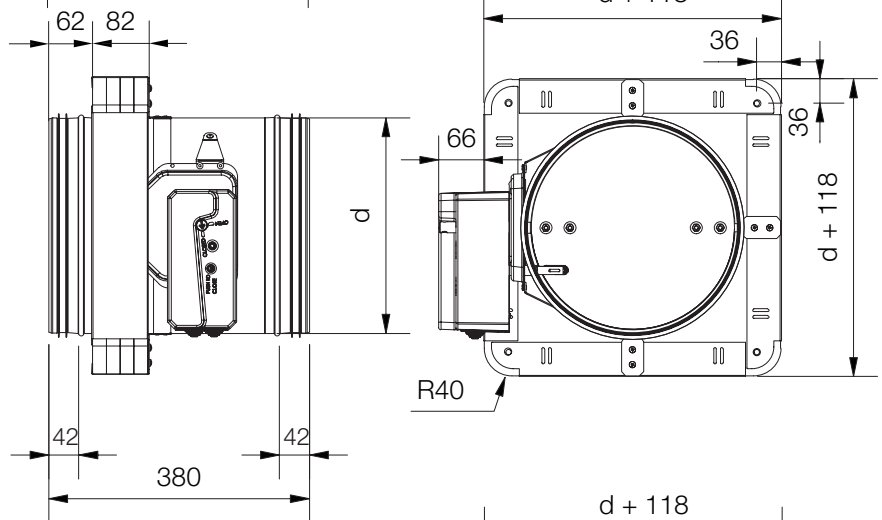

FDC25-MF1-M

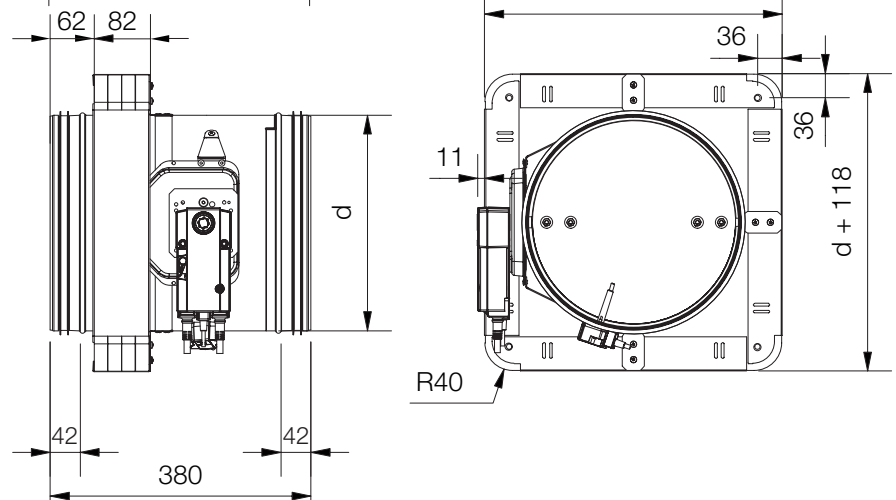

	FDC25-MF1-R						FDC25-MF1-EMS						FDC25-MF1-M					
Ød [mm]	100	125	160	200	250	315	100	125	160	200	250	315	100	125	160	200	250	315
Weight [kg]	6,6	7,4	8,7	10,3	12,5	15,5	8,1	8,9	10,2	11,8	14	17	7,3	8,1	9,4	11	13,2	16,2

* The images shown are for illustration purposes only and may not be an exact representation of the product.

MF2 installation frame

- MF2 is an installation frame for quick and easy installation in rigid and flexible walls
- Made out of calcium silicate boards
- Quick wall mounting with screws
- Factory assembled to the fire damper
- FD25-MF2 possible only for shaft wall installations!



FDC25-MF2-R

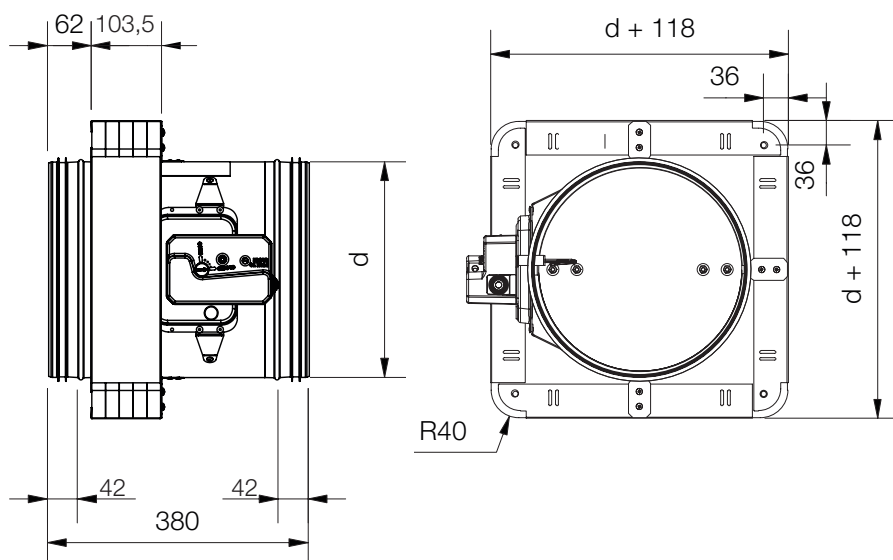

FDC25-MF2-EMS

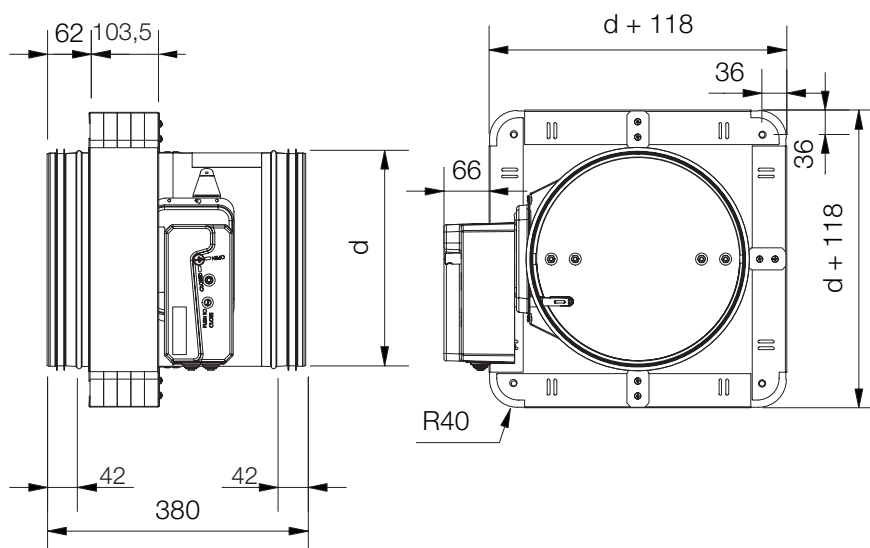

FDC25-MF2-M

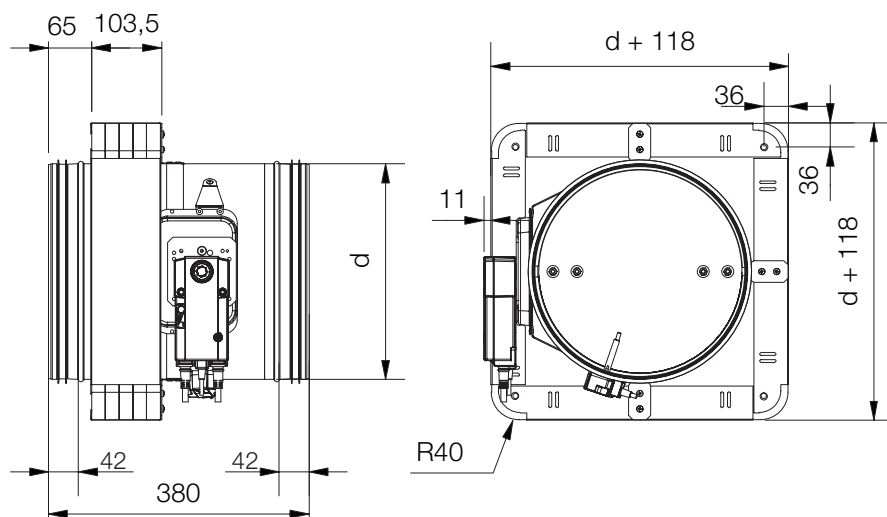

FDC40-MF2-R / FDC40-MF2-EMS

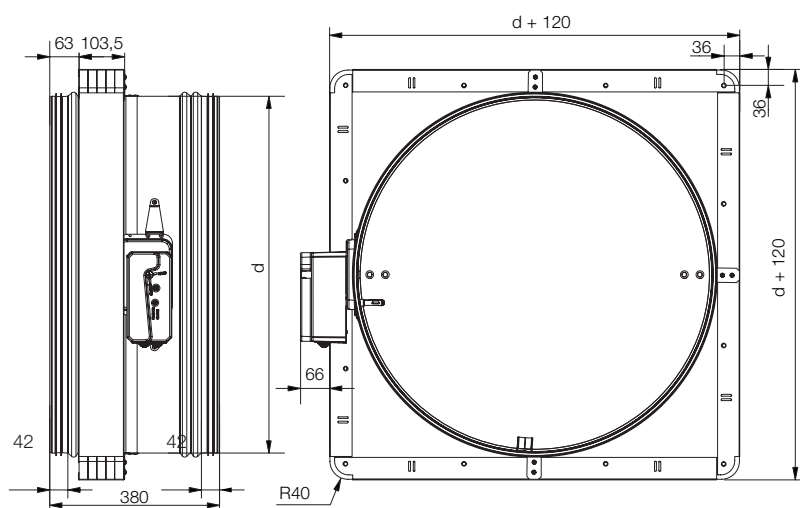

FDC40 -MF2-M

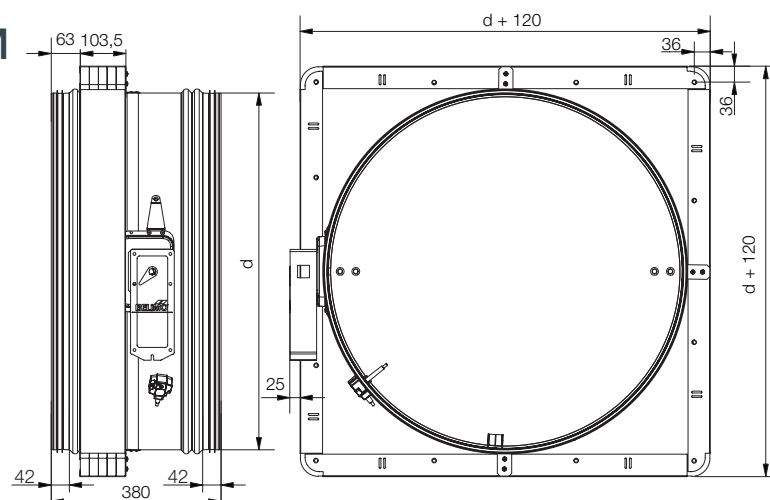

	FDC25-MF2-R						FDC25-MF2-EMS						FDC25-MF2-M					
Ød [mm]	100	125	160	200	250	315	100	125	160	200	250	315	100	125	160	200	250	315
Weight [kg]	7,1	8,1	9,6	11,4	13,8	17,2	8,6	9,6	11,1	12,9	15,3	18,7	7,8	8,8	10,3	12,1	14,5	17,9

* The images shown are for illustration purposes only and may not be an exact representation of the product.

INSTALLATION

The FDC25/FDC40 fire damper is always tested in standardized support frames (both in a rigid wall and in a flexible wall) in accordance with EN 1366-2: 2015 table 3/4/5. The results obtained are valid for all similar support frames which have a thickness and/ or density and/or fire resistance similar or greater than the one on the test.

The duct connected to the fire damper must be supported or hung in such a way that the damper does not carry its weight. The damper must not support any part of the surrounding construction or wall which could cause damage and consequent damper failure. It is recommended to connect the damper to a flexible connection on either end of the damper. The damper driving mechanism can be placed on either side of the wall, however it needs to be placed so that it ensures an easy access during inspection.

- Mounting is possible with the blade axis in horizontal or in vertical position
- The installation must comply with the tests that were performed during certification
- Avoid any obstruction of the moving blade by the connected ducts
- The class of air-tightness is maintained in case the installation of the damper is made in accordance with the technical manual
- Operating temperature: 50 °C max
- For indoor use only

The recommended / maximum installation opening is in the table below. The smallest installation opening is where there is enough space to install the seal!

Recommended opening dimensions:

Damper size - Ød [mm]	Gap size - GS (Recommended)	Opening size - (Recommended)
100	55 mm	110 mm
125	52,5 mm	105 mm
160	47,5 mm	95 mm
200	45 mm	90 mm
250	42,5 mm	85 mm
315	40 mm	80 mm
355	40 mm	80 mm
400	37,5 mm	75 mm
450	37,5 mm	75 mm
500	35 mm	70 mm
560	35 mm	70 mm
630	35 mm	70 mm
710	32,5 mm	65 mm
800	32,5 mm	65 mm

Installation in both, vertical and horizontal axis of rotation of the dampers blade is acceptable (with the axis angle 0 - 360°).

The fire damper must be installed into a fire partition structure in such a way that the damper blade in its closed position is located inside this structure (except for Applique/ MF1/ MF2 kit installations).

Casing extension pieces

Length of damper blade outside of casing (X dimension on front side): $X=(\text{Ød}/2)-110$ [mm]

*If the damper is larger than Ø 560, use formula (Y dimension on back side): $Y=(\text{Ød}/2)-270$ [mm]

Use of extension pieces (FD-A-EXT) is mandatory when safety grilles (FD-A-SG), flexible duct connections (FD-A-FLEX), or circular connections (FD-A-CIRC) are used on fire dampers with height H > 350mm.

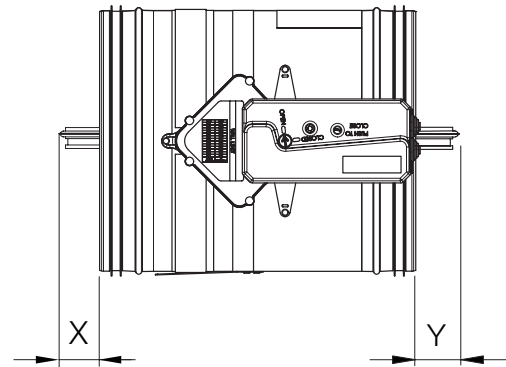

Casing tipe for manual and electric actuator

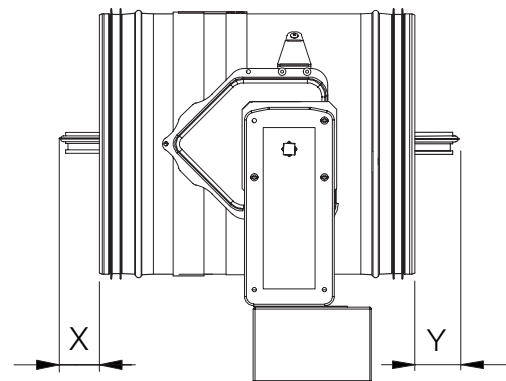

Casing tipe for Ex actuator and installations frames

Standard actuator positions

FDC-R25 MANUAL ACTUATOR

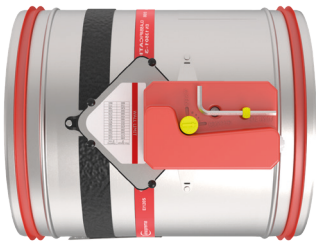

FDC25 ELECTRIC ACTUATOR

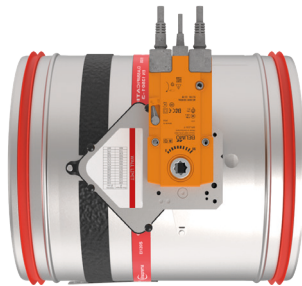

FDC40 ELECTRIC ACTUATOR

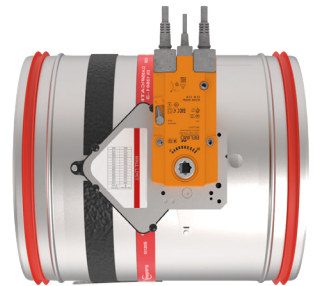

FDC-R40/EMS MANUAL ACTUATOR



FDC-R40/EMS ACTUATOR (Ød < 316)



FDC EX ACTUATOR



Assembly aid / Installation depth

To help you find the suspension plane, a bendable fixing bracket is provided on the damper body (the use of bendable fixing brackets is not required to meet the classification but they need to be bent up or broken in case they are not used. They must not stay in flat position.) and the red tape is placed on the casing to mark the location of the wall/ceiling limit (distance from wall/ceiling limit to the end of fire damper is 215 mm). This does not apply for Applique/MF1/MF2 kit installations. Check the operation of the fire damper before commencing the installation!

ASSEMBLY AID WITH FIXING BRACKET

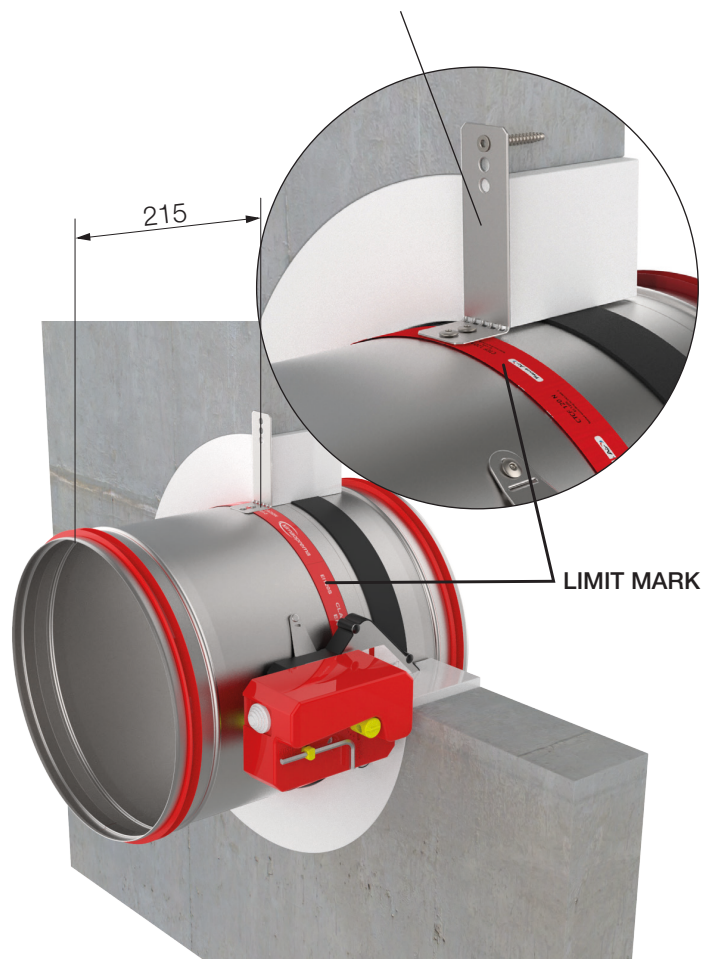

Installation possibilities

Flexible wall subframe

When installing the fire dampers in the flexible walls it is necessary to make a metal subframe. Into the damper can be fixed with the Assembly aid "fixing bracket" and screws on the metal subframe and plats.

Subframe should be prepared according to the manufacturer, current standards and guidelines and drawings below.

The required bay rails and stiffeners from the manufacturer should be used for installing FD fire dampers In metal stud walls so as to produce circumferential frames.

Intersections must be be connected with two blind rivets made from steel of 4 mm to 5 mm diameter or with Drywall screws of ≥ 3.5 mm diameter and ≥ 10 mm length.

Prefixing can also be performed using clinching (crimping), as is typical in dry construction. The joining points should be set twice. Furthermore, the claddings in the intersections must be connected to the metal studding using the usual double-connected screw fastenings.

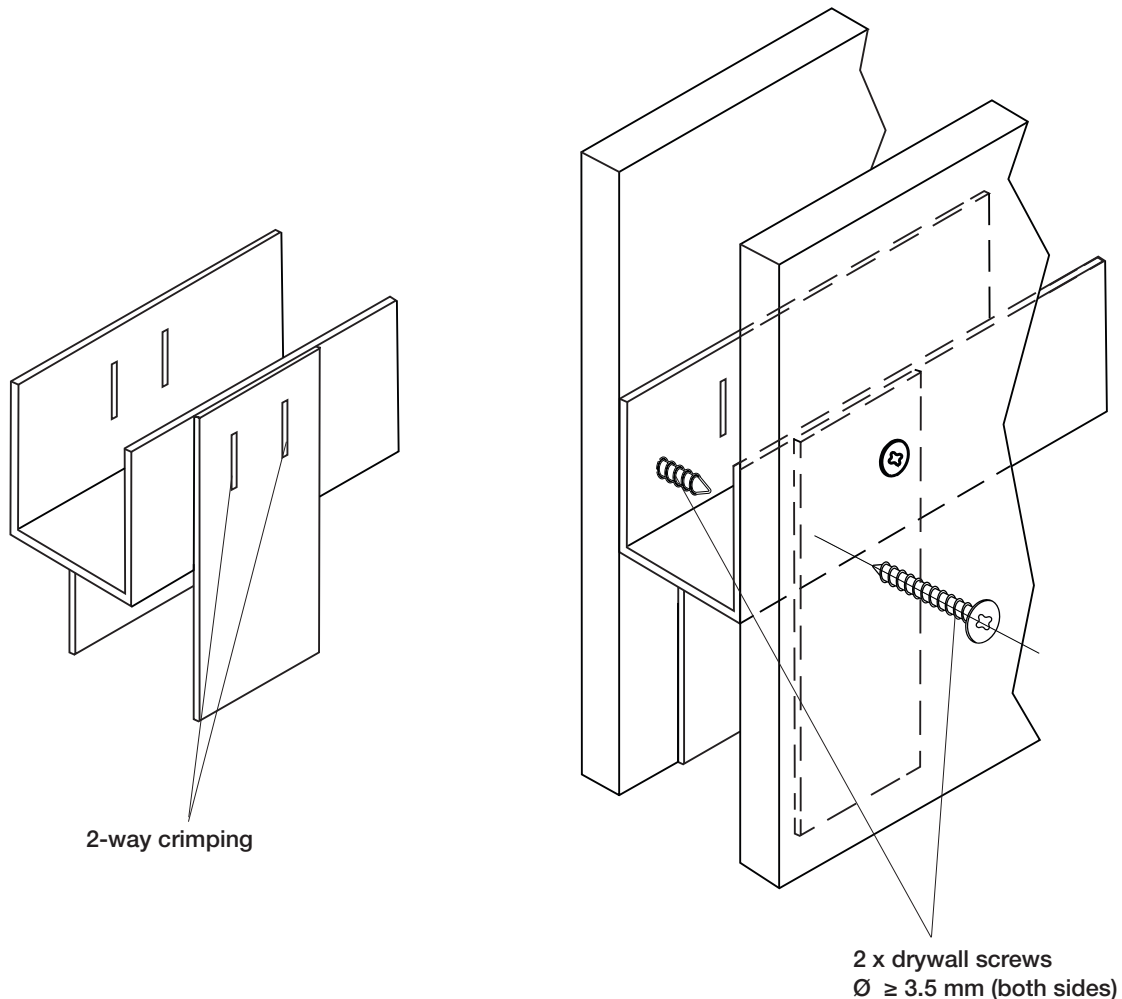

Recommended openings in lightweight partition walls with metal support structure

When installing the fire dampers in the lightweight partition walls with metal support structure it is necessary to make a metal subframe.

The uprights, cross profiles, and intermediate profiles for the lightweight partition wall subframe, should be prepared according to the drawings below.

Into the damper can be fixed with the Assembly aid “fixing bracket” and screws on the metal subframe and plats.

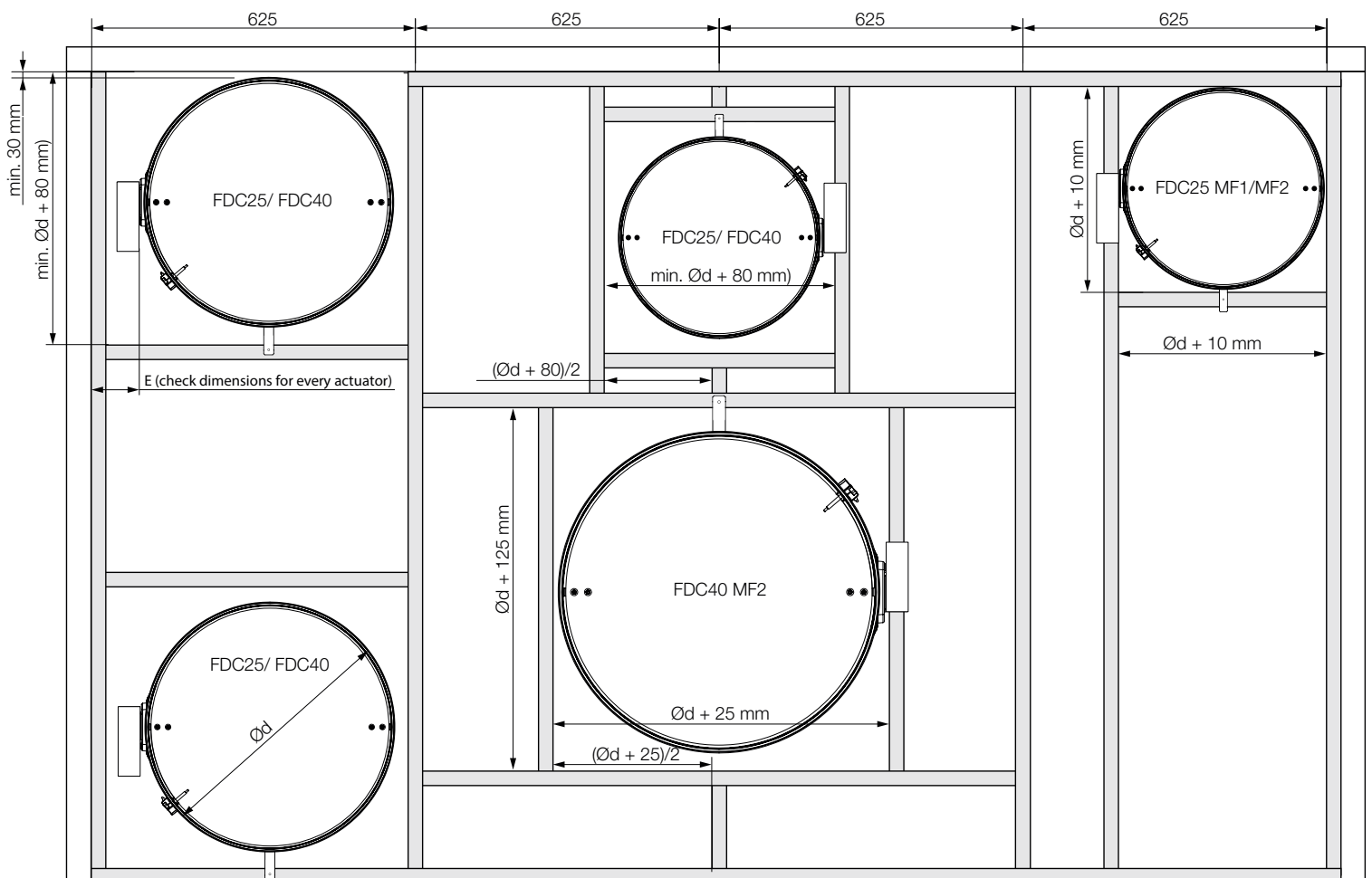



Supporting structures



Rigid Walls

- Rigid walls or compartment walls should be constructed from materials such as concrete ($\geq 2200 \text{ kg/m}^3$), aerated concrete ($\geq 450 \text{ kg/m}^3$) conforming to EN 12859 (without cavities).
- The wall thickness must be at least 100 mm. Each installation opening and cutout should be made in accordance with local and structural conditions, taking into account the size of the fire damper.
- Any cavities, such as those found in hollow concrete blocks or created by wall penetrations or cutouts, must be filled prior to the installation of the fire damper to ensure the fire resistance of the supporting structure is restored.



Gypsum blocks

- Gypsum blocks wall ($\geq 995 \text{ kg/m}^3$) according to EN 12859 (without cavities).
- Wall thickness at least 70 mm, provide each installation opening according to the local and structural conditions and with regard to the size of the fire damper.



Lightweight Partition Walls with Metal Support Structure

- Lightweight partition walls, safety partition walls, or radiation protection walls must feature a metal or steel support structure (box sections) and comply with European classification to EN 13501-2 or an equivalent national standard.
- The wall thickness must be $\geq 100 \text{ mm}$. The spacing between metal studs should not exceed 625 mm. Create an installation opening.
- Both sides should be clad with gypsum-bonded or cement-bonded panel materials, fiber-reinforced gypsum, or fire rated calcium silicate boards. If necessary, provide trim panels and secure them to the support structure with screws. Additional cladding layers (as specified in the wall's usability certificate) and double stud constructions are permitted.
- Connect the metal sections near the installation opening according to the installation guidelines provided in this manual on pg.16.
- If reinforcing boards are needed, secure them to the metal support structure at intervals of approximately 100 mm. Installation is permitted only in non-load-bearing walls (load-bearing wall constructions can be arranged upon request).
- Unless otherwise stated in the installation details, mineral wool with density up to 60 kg/m^3 and melting point $>1000^\circ\text{C}$ can be used.



Shaft Walls with Metal Support Structure

- Shaft walls must incorporate a metal or steel support structure and conform to European classification to EN 13501-2 or an equivalent national standard.
- The wall thickness must be at least 90 mm, with cladding of at least $2 \times 20 \text{ mm}$ cladding and reinforcing boards should follow the installation specifications. The spacing between metal studs should not exceed 625 mm.
- One side should be clad with gypsum-bonded or cement-bonded panel materials, fiber-reinforced gypsum, or fire-rated calcium silicate boards. Ensure adherence to the manufacturer's guidelines regarding the height, width, and thickness of walls.
- Create an installation opening. If necessary, provide trim panels and secure them to the support structure with screws. Installation should be performed with the actuator positioned on the outside of the shaft.
- If reinforcing boards are needed, secure them to the metal support structure at intervals of approximately 100 mm.



Cross-laminated timber (CLT) walls

- Cross-laminated timber walls ($\geq 480 \text{ kg/m}^3$) must have a European or national certification. The wall thickness must be at least 100 mm.



Eurobond Firemaster Extra

- Eurobond Firemaster Extra should be classified according to EN 13501-1:2018. The wall thickness should be at least 100 mm.



Installation materials



Mortar sealing installation

Protect all openings and control elements of the fire damper (e.g., with plastic) to prevent contamination.

For mortar sealing installations, it may be necessary to support the sides of the fire damper casing to prevent deformation, such as using a prop. Center the fire damper in the installation opening, then push it in until the distance between the operating side flange and the wall or ceiling is 215 mm; secure the fire damper in this position by fixing the suspension bracket to the wall.

For mortar-based installations, the gaps between the fire damper casing and the wall or ceiling slab must be filled with mortar. Avoid trapping air. The depth of the mortar bed should match the wall thickness but must be at least 100 mm. If the fire damper is installed while the solid wall or ceiling slab is being constructed, a perimeter gap is not required. Ensure the gaps between the fire damper and the wall are sealed with mortar; for installations in solid ceiling slabs, use concrete. Reinforcement must meet structural specifications.

Mortar

- DIN 1053: Groups II, IIa, III, IIIa; fire protection mortar of groups II, III
- EN 998-2: Classes M 2.5 to M 20 or fire protection mortar of classes M 2.5 to M 20
- Equivalent mortars that meet the requirements of the above standards, gypsum mortar or concrete



Mineral wool sealing installation

Unless otherwise stated in the installation details, mineral wool with a gross density of $\geq 80 \text{ kg/m}^3$ and a melting point of $\geq 1000 \text{ }^\circ\text{C}$ must be used.



Installation with Fire Batt

The distance from the operating side flange to the wall/ceiling must be 215 mm.

Fire batt systems consist of two layers of mineral wool slabs with a gross density of $\geq 140 \text{ kg/m}^3$.

Apply fire-resistant sealant to the cut edges of the mineral wool slabs and fit them snugly into the installation opening. Seal any gaps between the mineral wool slabs and the installation opening, as well as between the cut edges of custom-sized pieces and the fire damper, using fire-resistant sealant or coating that is compatible with the fire batt system. Apply ablative coating to the mineral wool slabs, joints, transitions, and any imperfections on the coated mineral wool slabs, ensuring a coating thickness of $\geq 2.5 \text{ mm}$. Secure fire dampers on both sides of the wall, as per instructions in this manual.

Filling made only from Hilti foam With this installation we recommend using flexible connection (see accessory FCR) due to thermal expansion of connected ducts during fire. Install the compensator so, that the flexible part has a minimum distance of 50 mm from the edge of a damper's blade in open position.

The following fire batt systems are acceptable (fire batt systems have to be provided by others). As for mineral wool slabs, all slabs that are part of the system and have been approved by the manufacturer may be used.

- Promastop®-CC
- Ablative coating Promastop®-I
- Ablative coating Intumex-CSP
- Ablative coating Intumex-AC Hilti

Suspension

For installations away from walls and ceilings, or for firebatt installations, fire dampers should be hung with steel threaded rods (M10 – M12). These rods must be attached to the ceiling slab without compromising the required fire resistance. Only fire-rated steel anchors with proper certification should be used.

Alternatively, threaded rods can be secured with nuts and washers in place of anchors. Ensure the rods are fastened above the ceiling using steel nuts and washers. Rods up to 1.50 m in length do not need insulation, but longer ones require insulation (as per Promat® worksheet 478, for example).

The suspension system should support only the weight of the fire damper, and the ducting must be suspended separately.



Declaration of performance
INSTALLATION

Check for more information about certificate installations in the declaration of performance:

www.klimaoprema.com/fdc/

 Aerated concrete ($\geq 450 \text{ kg/m}^3$) or reinforced concrete ($\geq 2200 \text{ kg/m}^3$) wall, more than 100 mm thick

 Gypsum blocks ($\geq 995 \text{ kg/m}^3$) wall, more than 70 mm thick

 Plasterboard wall, type F (EN520), Plasterboard wall, type A (EN520), more than 100 mm thick

 Shaft wall, steel frame construction

 Aerated concrete ($\geq 450 \text{ kg/m}^3$) or reinforced concrete ($\geq 2200 \text{ kg/m}^3$) ceiling / floor, more than 100 mm thick

 Gypsum plaster, mortar sealing od mortar and cover boards

 Sealing with mineral wool and cover boards





























 Sealing with mineral wool and fireproof coating - FireBatt

 Applique kit installation

 MF1/MF2 kit installation

 Remote from wall installation

 Battery installation

Range	Supporting construction	Type of installation
FDC25 d100-d315 mm / FDC40 d355-d800 mm	Rigid wall	  Gypsum plaster / Mortar
		  Mineral wool and cover boards
		  Fire Batt/ Weichschott
		  Gypsum plaster / Mortar and cover boards
FDC25 d100-d315 mm / FDC40 d355-d800 mm	Flexible wall	  Gypsum plaster / Mortar
		  Gypsum plaster / Mortar and cover boards
		  Mineral wool and cover boards
		  Fire Batt/ Weichschott
		  Fire Batt/ Weichschott
		  Fire Batt/ Weichschott
		  Eurobond Firemaster Extra
		FDC25 d100-d315 mm / FDC40 d355-d800 mm
  Gypsum plaster / Mortar and cover boards + Mineral wool (115 kg/m^3)		
FDC25 d100-d315 mm / FDC40 d355-d800 mm	Floor/ceiling	  Gypsum plaster / Mortar
		  Fire Batt/ Weichschott

Classification	Supporting construction details	Wall thickness	Tested underpressure	Construction type
EI 120 (ve i↔o)S			500Pa	pg. 24
EI 90 (ve i↔o)S	Aerated concrete (≥ 450kg/m ³) Reinforced concrete (≥ 2200kg/m ³)	≥ 100 mm	500Pa	pg. 26
			300Pa	pg. 28
EI 120 (ve i↔o)S	Gypsum blocks (≥ 995kg/m ³)	≥ 70 mm	500Pa	pg. 30
A: FDC 25 EI 90 (ve i↔o)S A: FDC 40 EI 120 (ve i↔o)S B: EI 60 (ve i↔o)S			300Pa	pg. 32
A: EI 120 (ve i↔o)S B: EI 60 (ve i↔o)S	A: Plasterboard type F (EN520), mineral wool up to 115 kg/m ³	≥ 100 mm	500Pa	pg. 34
A: EI 90 (ve i↔o)S B: EI 60 (ve i↔o)S	B: Plasterboard type A (EN520), mineral wool up to 60 kg/m ³		500Pa	pg. 36
A: EI 90 (ve i↔o)S B: EI 60 (ve i↔o)S			300Pa	pg. 38
EI 45 (ve i↔o)S	Plasterboard type F (EN520), mineral wool up to 115 kg/m ³	≥ 75 mm	300Pa	pg. 40
EI 90 (ve i↔o)S	Cross laminated timber (30+40+30 mm) (480 kg/m ³)	≥ 100 mm	300Pa	pg. 42
FDC25:EI 60 (i↔o)S FDC40: EI 60 S/ E 90 S (i↔o)S	Mineral wool (≥ 23 kg/m ³)		300Pa	pg. 44
EI 120 (ve i↔o)S	Aerated concrete (≥ 450 kg/m ³)	≥ 100 mm	300Pa	pg. 46
EI 120 (ve i↔o)S	Plasterboard type F (EN520)	≥ 100 mm	300Pa	pg. 48
EI 120 (ho i↔o)S			500Pa	pg. 50
EI 90 (ho i↔o)S	Aerated concrete (≥ 450kg/m ³) Reinforced concrete (≥ 2200kg/m ³)	≥ 100 mm	300Pa	pg. 52



Declaration of performance
**INSTALLATION WITH
 SUBFRAMES AND REMOTE
 FROM WALLS**

Check for more information about certificate installations in the declaration of performance:

www.klimaoprema.com/fdc/

 Aerated concrete ($\geq 450 \text{ kg/m}^3$) or reinforced concrete ($\geq 2200 \text{ kg/m}^3$) wall, more than 100 mm thick

 Gypsum blocks ($\geq 995 \text{ kg/m}^3$) wall, more than 70 mm thick

 Plasterboard wall, type F (EN520), Plasterboard wall, type A (EN520), more than 100 mm thick

 Shaft wall, steel frame construction

 Aerated concrete ($\geq 450 \text{ kg/m}^3$) or reinforced concrete ($\geq 2200 \text{ kg/m}^3$) ceiling / floor, more than 100 mm thick

 Gypsum plaster, mortar sealing od mortar and cover boards

 Sealing with mineral wool and cover boards

 Sealing with mineral wool and fire-proof coating - FireBatt

 Applique kit installation

 MF1/MF2 kit installation

 Remote from wall installation

 Battery installation

Range	Supporting construction	Type of installation
APP INSTALLATION FRAME FDC25 d100-d315 mm	Rigid wall	APPLIQUE (installation frame)
		APPLIQUE (installation frame)
	Flexible wall	APPLIQUE (installation frame)
MF1/ MF2 INSTALLATION FRAME FDC25 MF1 d100-d315 mm FDC40 MF2 d355-d800 mm		MF1 (installation frame)
	Rigid wall	MF2 (installation frame)
		MF1 (installation frame)
		MF2 (installation frame)
	Flexible wall	MF1 (installation frame)
		MF2 (installation frame)
MF2 INSTALLATION FRAME FDC25 MF2 d100-d315 mm FDC40 MF2 d355-d800 mm	Floor/ceiling	MF2 (installation frame)
	Flexible wall	MF2 (installation frame)
ISOVER FDC25 d100-d315 mm FDC40 d355-d630 mm	Flexible wall	REMOTE FROM WALL (Isover)
	Rigid wall	

Classification	Supporting construction details	Wall thickness	Tested underpressure	Page number
EI 90 (ve i↔o)S	Aerated concrete ($\geq 450\text{kg/m}^3$) Reinforced concrete ($\geq 2200\text{kg/m}^3$)	≥ 100 mm	500Pa	pg. 58
EI 90 (ve i↔o)S	Gypsum blocks ($\geq 995\text{kg/m}^3$)	≥ 70 mm	500Pa	pg. 60
EI 90 (ve i↔o)S EI 60 (ve i↔o)S	Plasterboard type F (EN520) A (EN520)	≥ 100 mm	500Pa	pg. 62
FDC25:EI 60 (ve i↔o)S	Aerated concrete ($\geq 450\text{kg/m}^3$) Reinforced concrete ($\geq 2200\text{kg/m}^3$)	≥ 100 mm	500Pa	pg. 64
EI 90 (ve i↔o)S			FDC25: 300Pa FDC40: 500Pa	
FDC25:EI 60 (ve i↔o)S	Gypsum blocks ($\geq 995\text{kg/m}^3$)	≥ 70 mm	500Pa	pg. 66
EI 90 (ve i↔o)S				
A:FDC25:EI 60 (ve i↔o)S B:FDC25:EI 60 (ve i↔o)S	Plasterboard A:type A (EN520) B:type F (EN520)	≥ 100 mm	500Pa	pg. 68
A:EI 60 (ve i↔o)S B:EI 90 (ve i↔o)S			FDC25: 300Pa FDC40: 500Pa	
FDC40:EI 90 (ho i↔o)S	Aerated concrete ($\geq 450\text{kg/m}^3$) Reinforced concrete ($\geq 2200\text{kg/m}^3$)	≥ 100 mm	300Pa	pg. 70
EI 60 (ve i↔o)S	Shaft wall (steel frame)	≥ 75 mm	300Pa	pg. 72
EI 90 (ve i↔o)S		≥ 90 mm		
EI 60 (ve i↔o)S	Plasterboard type F (EN520)	≥ 100 mm	300Pa	pg. 74
	Aerated concrete ($\geq 450\text{kg/m}^3$) Reinforced concrete ($\geq 2200\text{kg/m}^3$)			pg. 76

Rigid wall installation (mortar sealing)

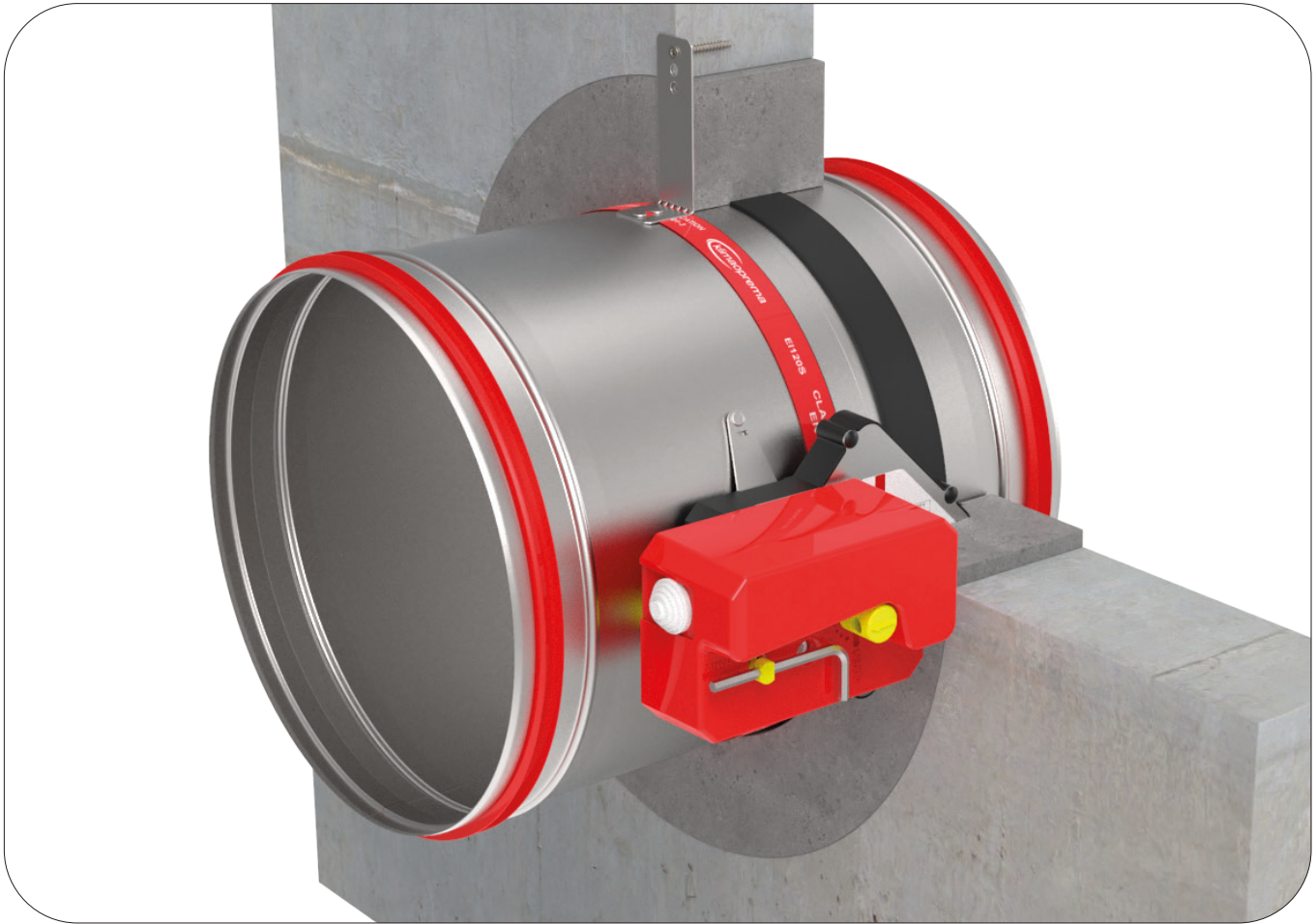

The wall is composed of concrete blocks (minimum density of 450 kg/m³) or reinforced concrete (minimum density of 2200 kg/m³) and with a minimum thickness of 100 mm. Installation material is gypsum plaster or mortar.

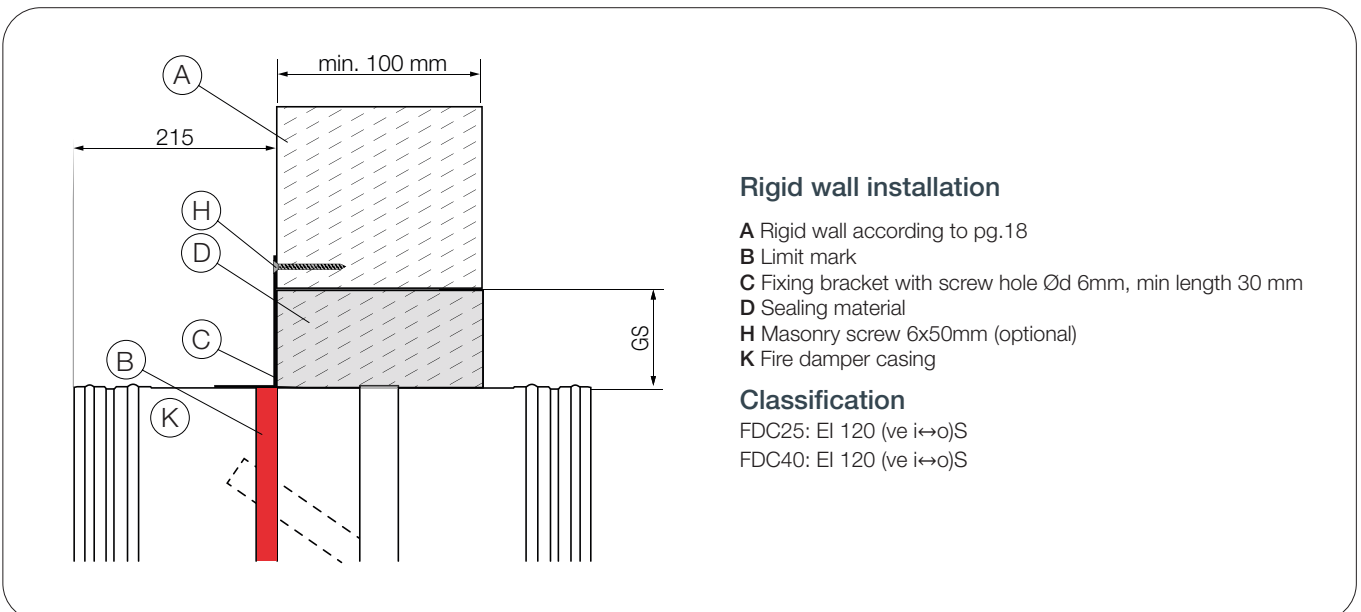



DOP



WALLS



MATERIALS

Possible damper orientations



0-360°

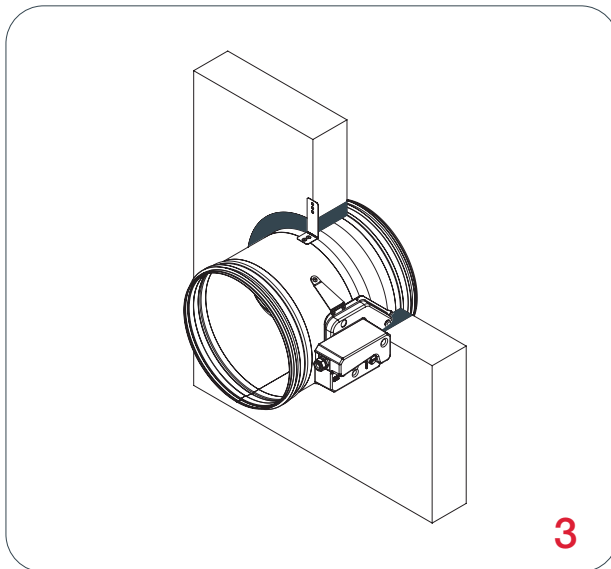
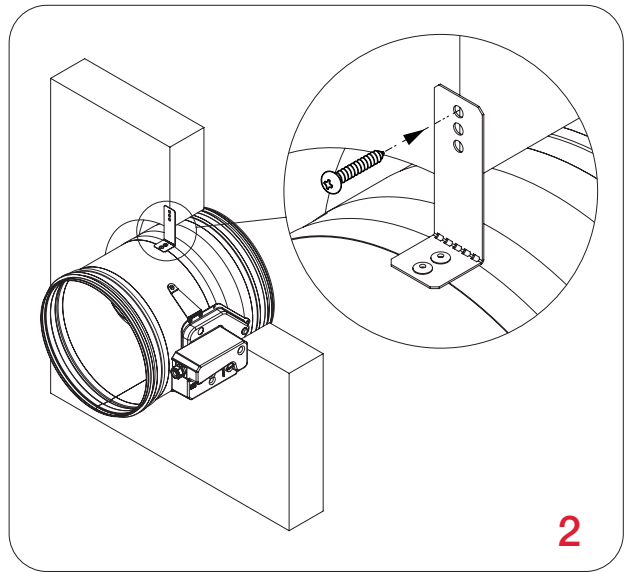
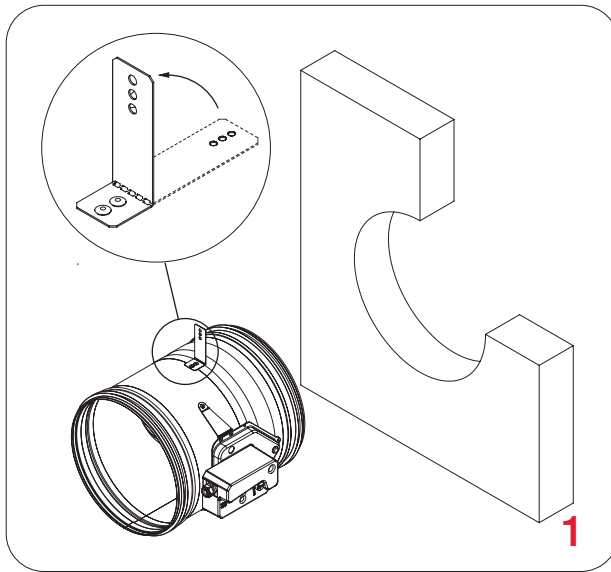

Damper size- Ød [mm]	Gap size - GS
100	55 mm
125	52,5 mm
160	47,5 mm
200	45 mm
250	42,5 mm
315	40 mm
355	40 mm
400	37,5 mm
450	37,5 mm
500	35 mm
560	35 mm
630	35 mm
710	32,5 mm
800	32,5 mm

Damper blade must be closed during the installation!

1. Create an opening in the wall. Bend the fixing bracket 90°. Place the damper in the opening up to the wall limit mark on the damper.
2. Fix the damper to the wall using screws. Bracket screw hole is 6 mm in diameter.
3. Fill the space between the damper and the wall with gypsum plaster or mortar.

*Multiple fire dampers can be installed next to each other or ceiling/wall with the minimal distance of 30 mm between them, [see page 17](#).

Test the operation of the damper blade!

Rigid wall installation (mineral wool sealing)

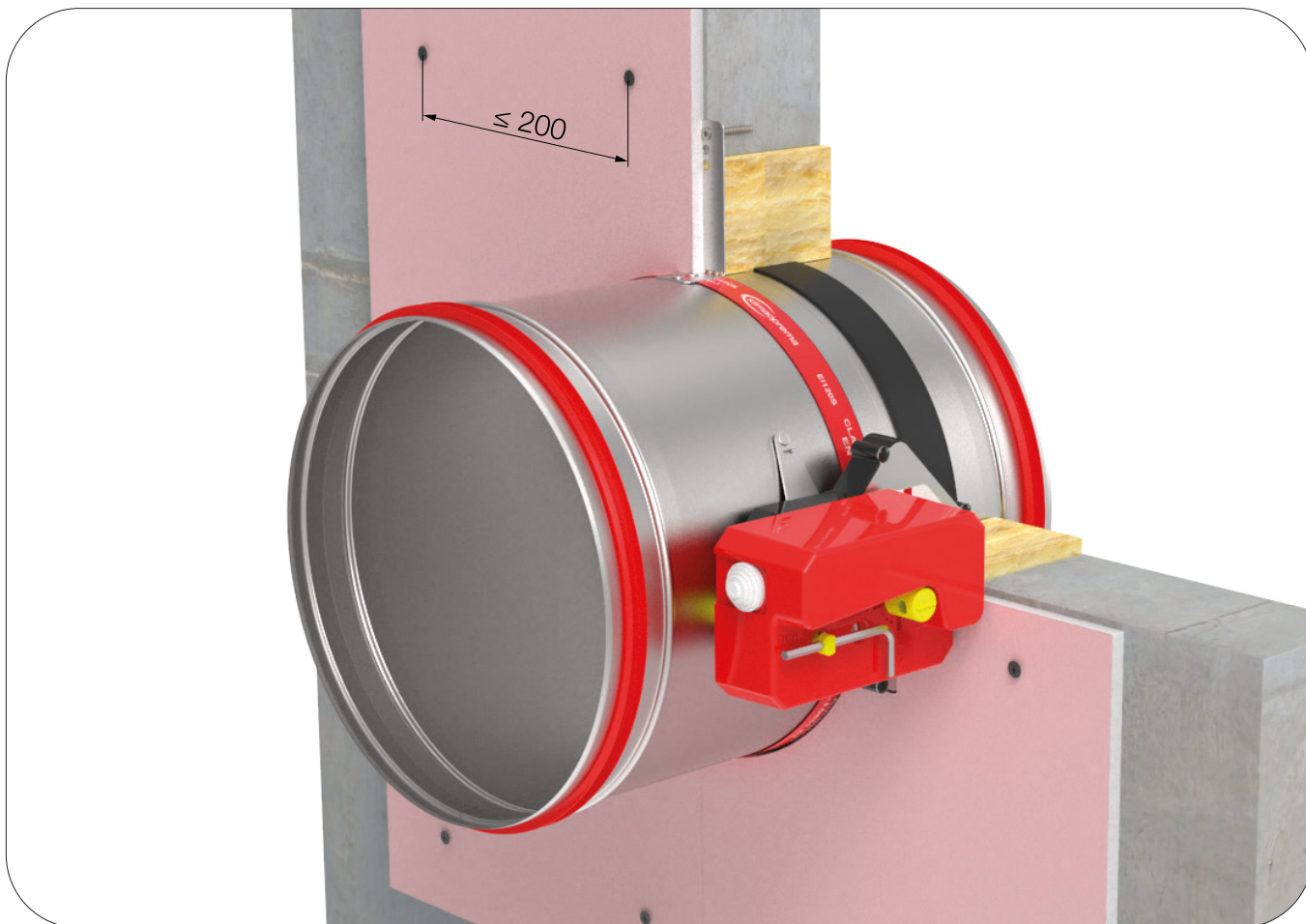

The wall is composed of concrete blocks (minimum density of 450 kg/m³) or reinforced concrete (minimum density of 2200 kg/m³) and with a minimum thickness of 100 mm.
Installation material is mineral wool (minimum density of 100 kg/m³) covered with plasterboard cover boards.

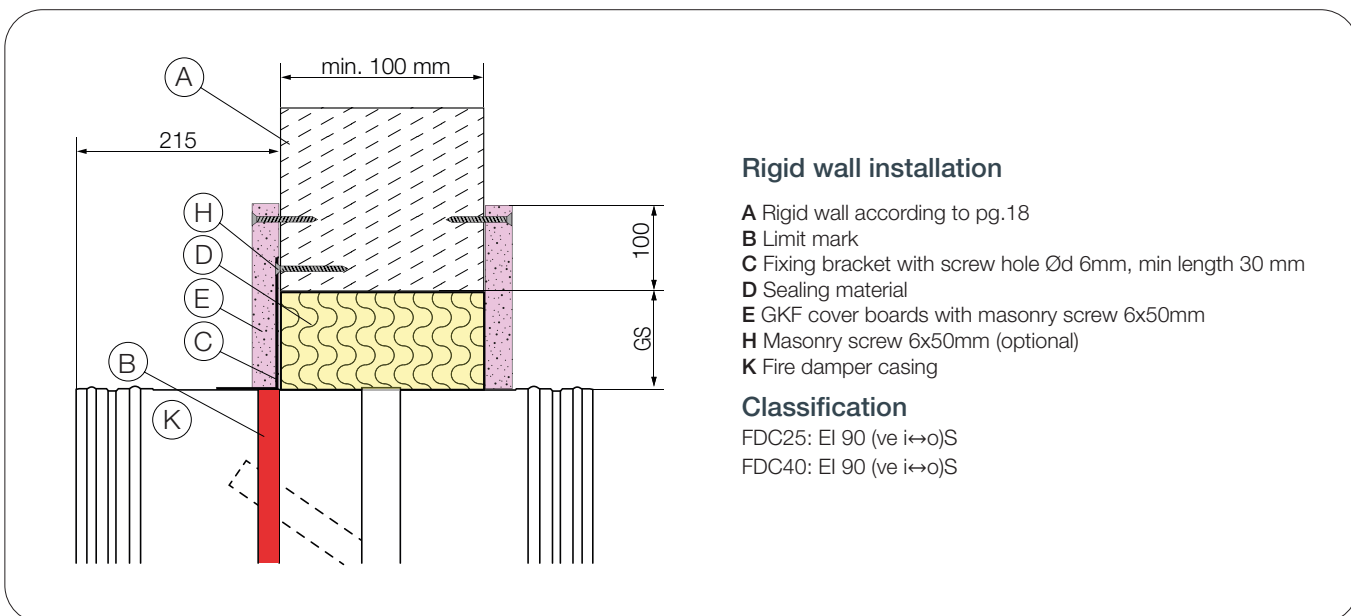



DOP



WALLS



MATERIALS

Possible damper orientations

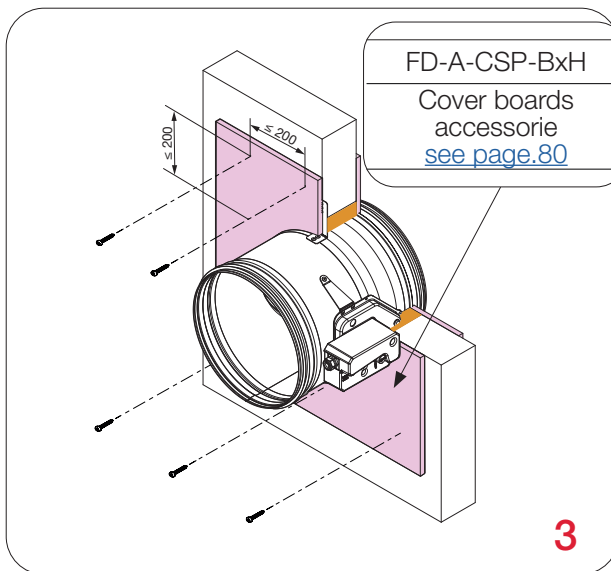
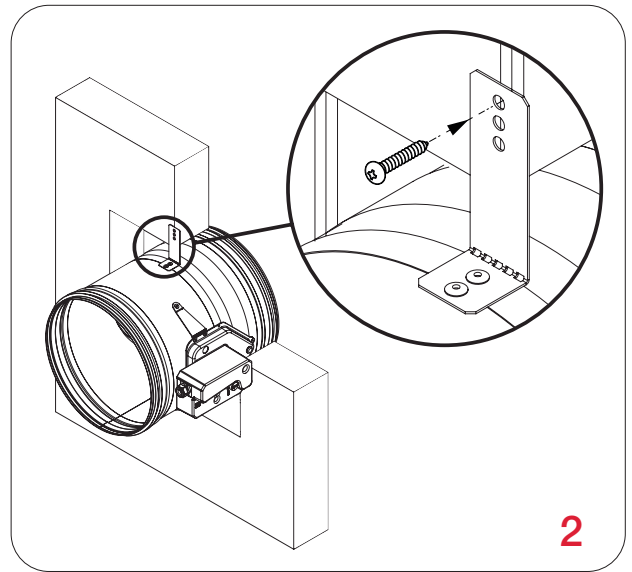
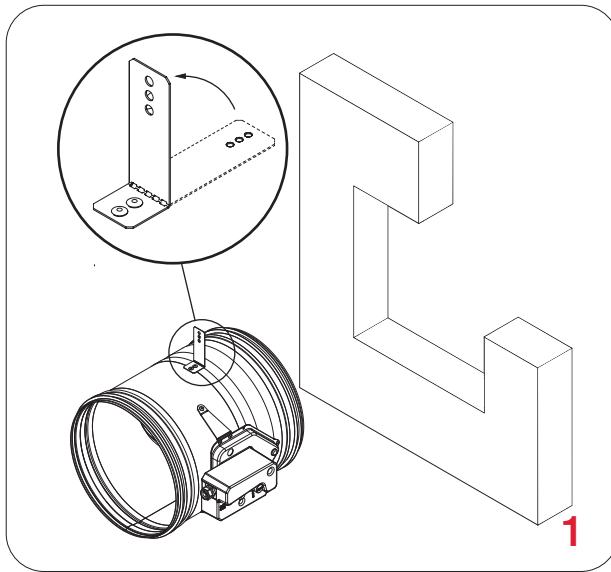

Damper size- Ød [mm]	Gap size - GS
100	55 mm
125	52,5 mm
160	47,5 mm
200	45 mm
250	42,5 mm
315	40 mm
355	40 mm
400	37,5 mm
450	37,5 mm
500	35 mm
560	35 mm
630	35 mm
710	32,5 mm
800	32,5 mm

Damper blade must be closed during the installation!

1. Create an opening in the wall. Bend the fixing bracket 90°. Place the damper in the opening up to the wall limit mark on the damper.
2. Fix the damper to the wall using screws. Bracket screw hole is 6 mm in diameter.
3. Fill the space between the damper and the wall with mineral wool. Cover the mineral wool with GKF gypsum boards (12,5 mm thick), fix them with screws.

*Multiple fire dampers can be installed next to each other or ceiling/wall with the minimal distance of 30 mm between them, [see page 17](#).

Test the operation of the damper blade!

Rigid wall installation (Fire Batt/Weichschott)

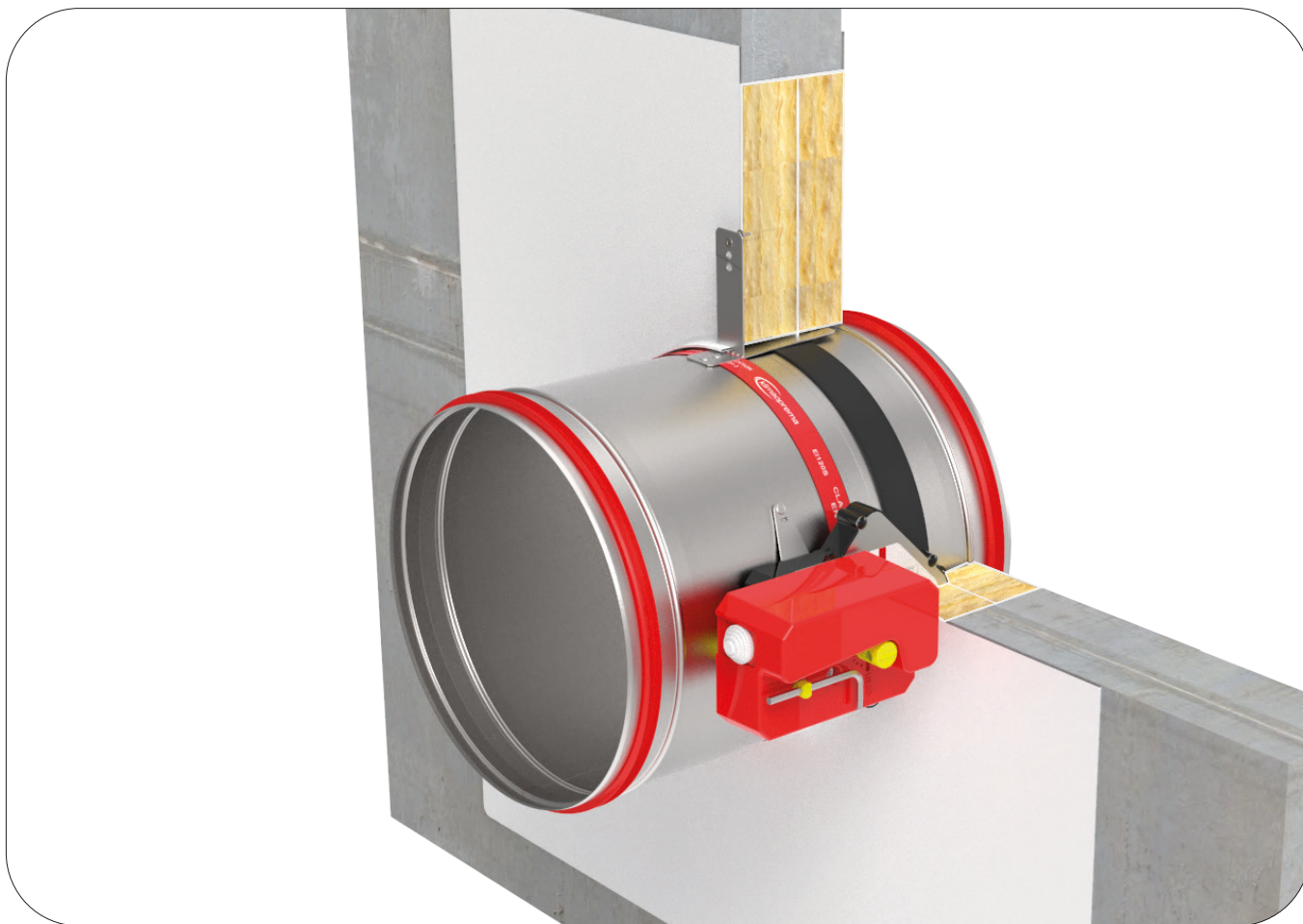

The wall is composed of concrete blocks (minimum density of 450 kg/m^3) or reinforced concrete (minimum density of 2200 kg/m^3) and with a minimum thickness of 100 mm.
Installation material: Mineral wool (minimum density of 140 kg/m^3), fire protection coating.

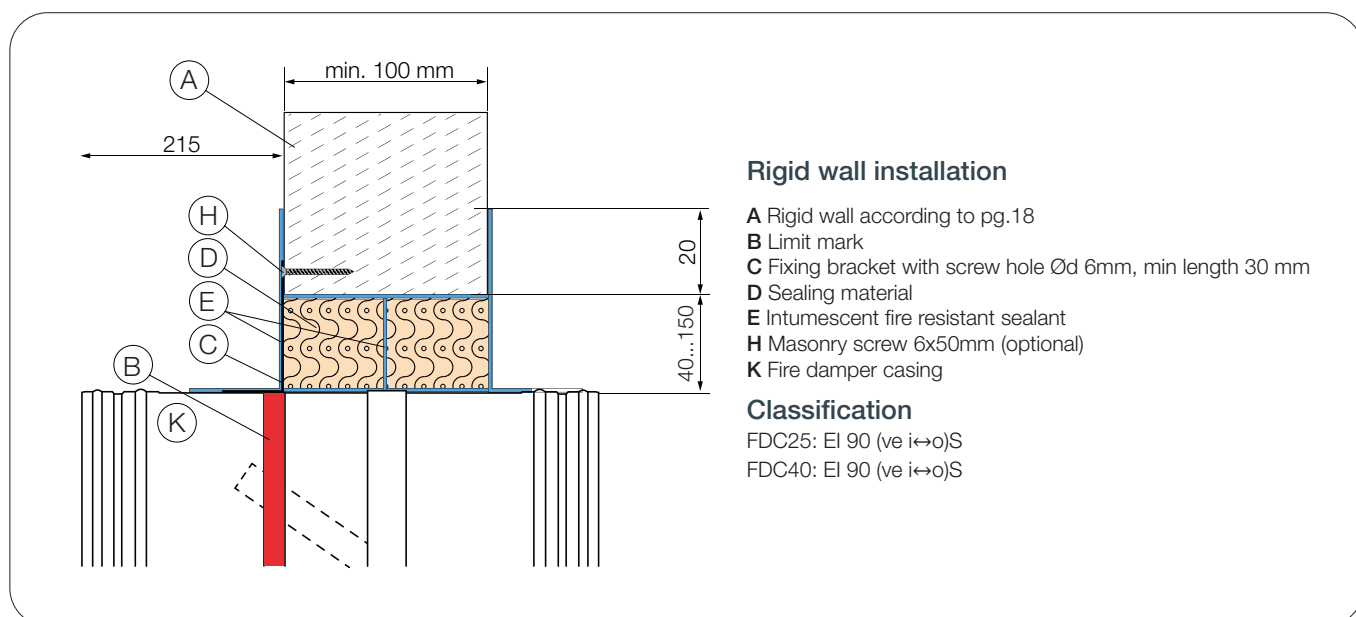



[Video instructions](#)



DOP



WALLS



MATERIALS

Possible damper orientations

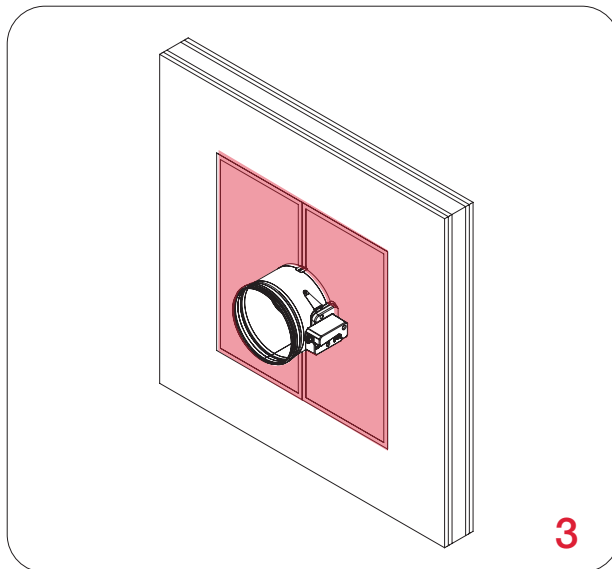
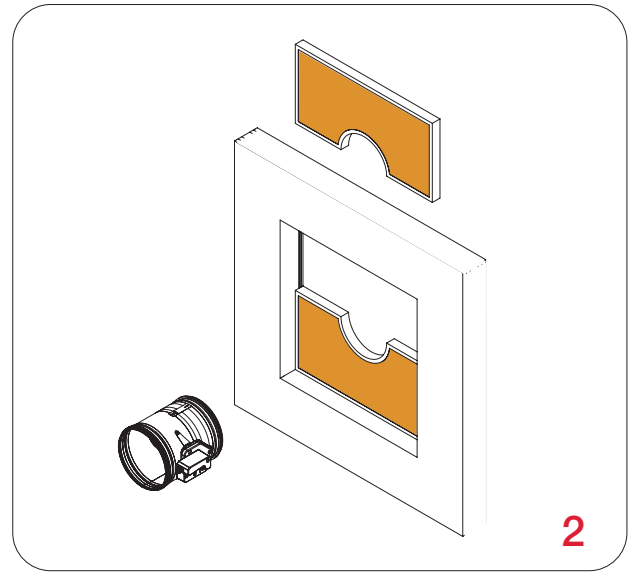
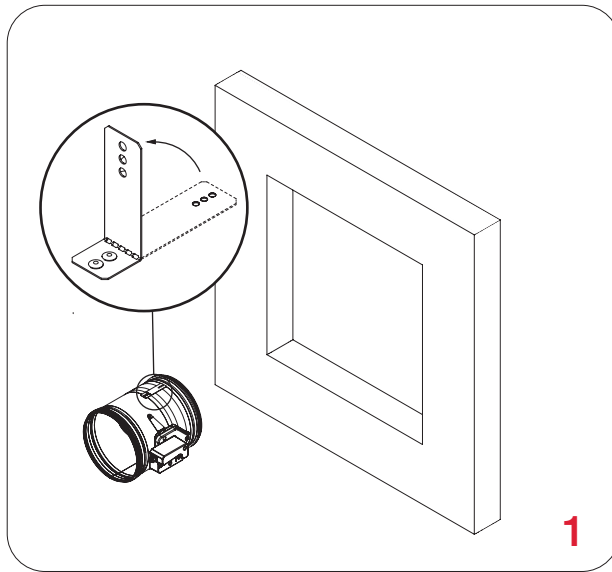

Damper blade must be closed during the installation!

1. Create an opening in the wall ($\text{Ød} + 80...300 \text{ mm}$) x ($\text{Ød} + 80...300 \text{ mm}$). Bend the mounting bracket by 90° . Insert the damper into the opening up to the wall boundary mark on the damper.
2. Close the gap between the housing and the wall with the first layer of mineral wool (50 mm thick, coated on the inside). Seal the joints between the pieces of mineral wool with intumescent, fire-resistant sealant.
3. Close the gap between the housing and the wall with the second layer of mineral wool (50 mm thick, coated on the inside). The joints between the mineral wool pieces must be sealed with intumescent, fire-resistant sealant. The outside of the mineral wool and the damper housing must be coated with a 2 mm thick fire protection coating. The damper housing should be coated up to the profile projections.

*Multiple fire dampers can be installed next to each other or ceiling/wall with the minimal distance of 30 mm between them, [see page 17](#).

Test the operation of the damper blade!

Gypsum blocks wall installation (mortar sealing)

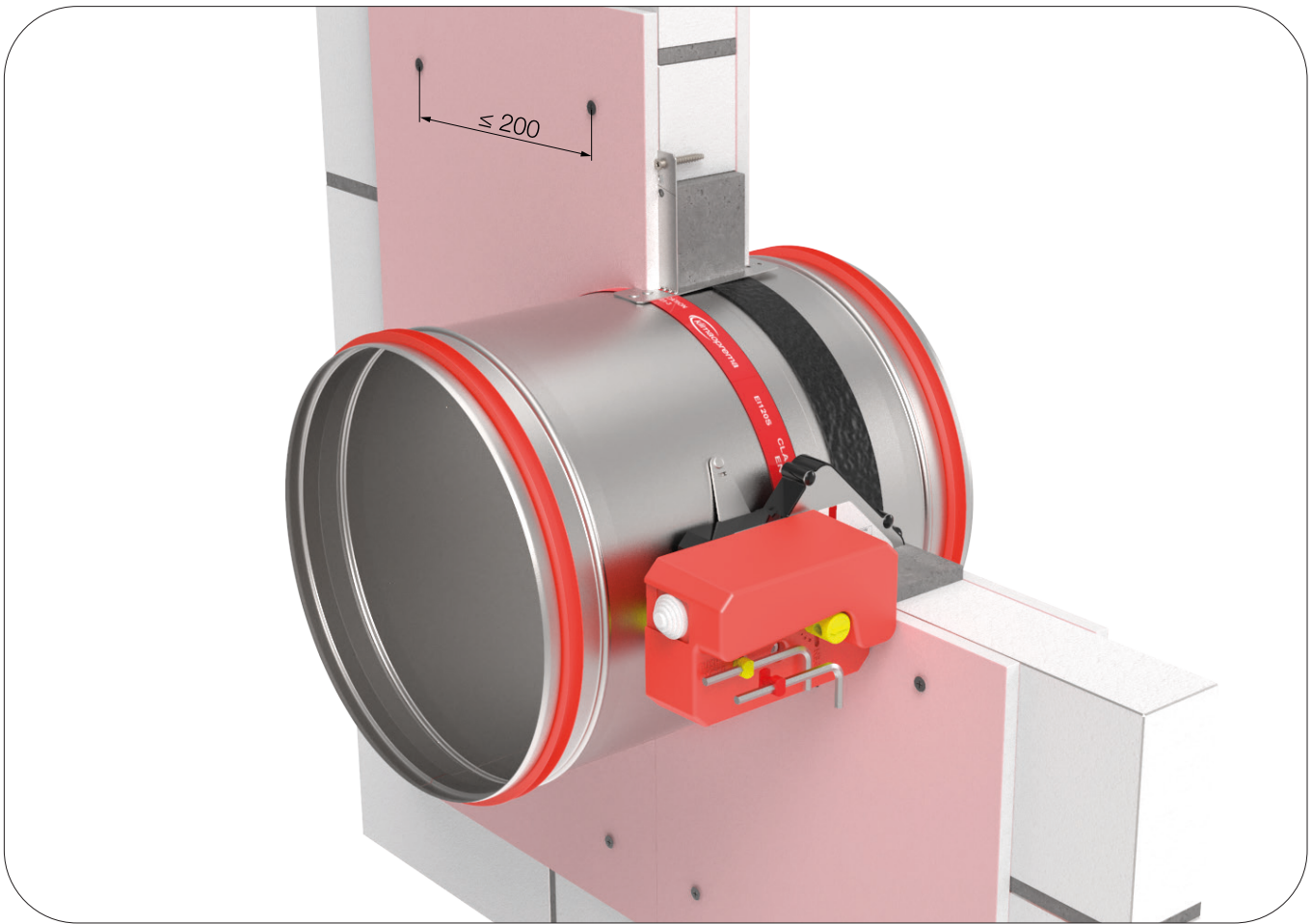

The wall is composed of gypsum blocks (minimum density of 995 kg/m³), with minimum thickness of 70 mm. Installation material is gypsum plaster or mortar covered with plasterboard cover boards.

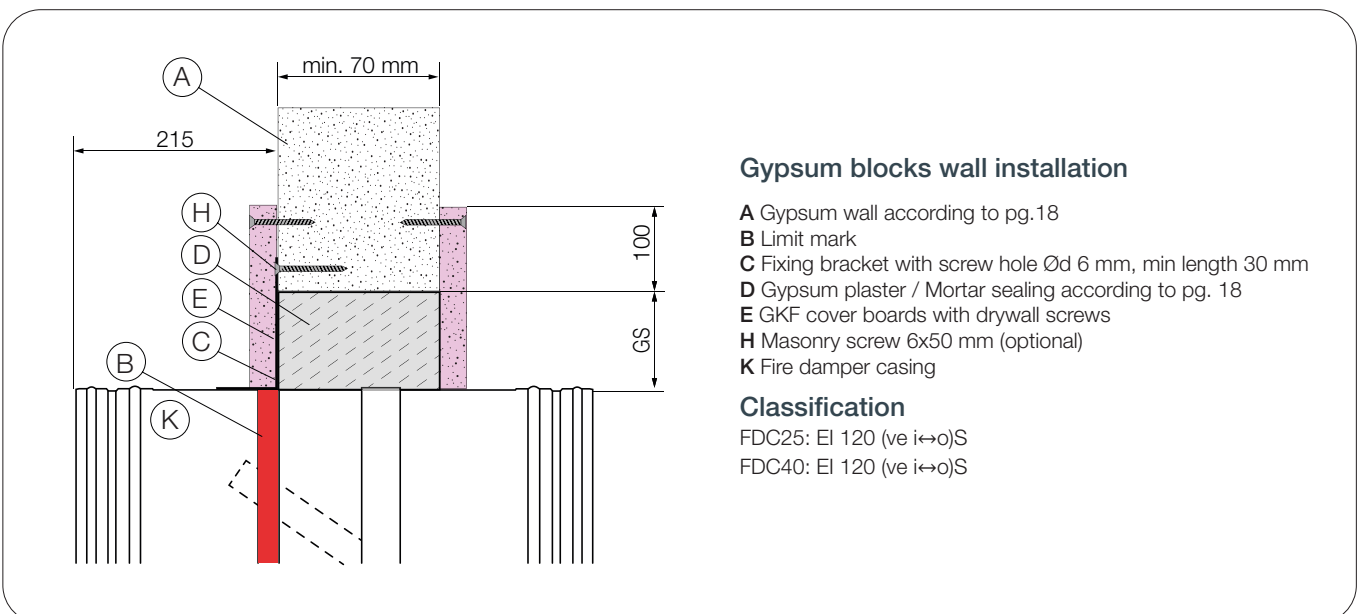



DOP



WALLS



MATERIALS

Possible damper orientations

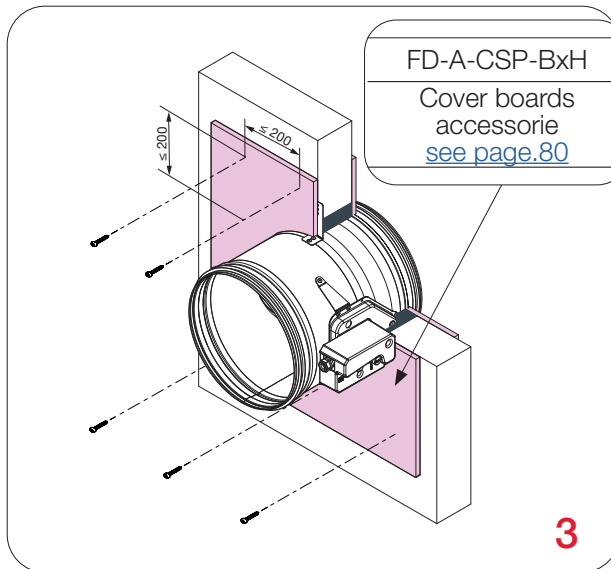
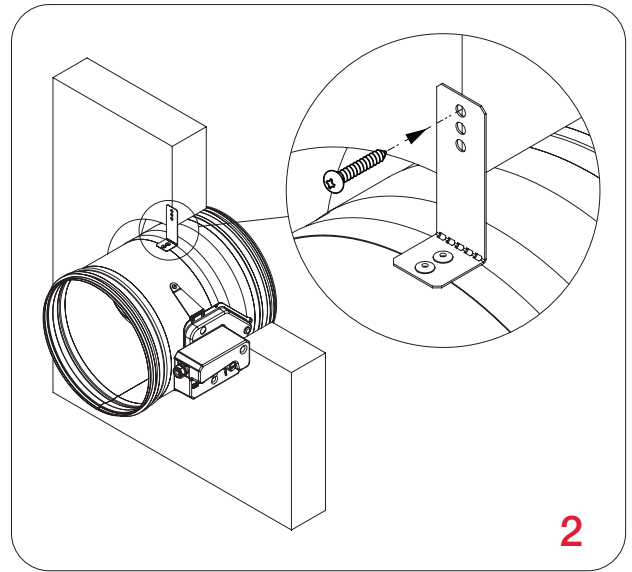
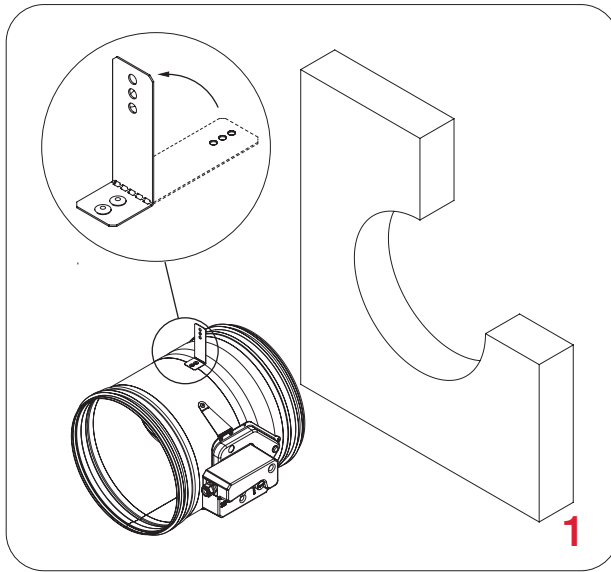

Damper size- Ød [mm]	Gap size - GS
100	55 mm
125	52,5 mm
160	47,5 mm
200	45 mm
250	42,5 mm
315	40 mm
355	40 mm
400	37,5 mm
450	37,5 mm
500	35 mm
560	35 mm
630	35 mm
710	32,5 mm
800	32,5 mm

Damper blade must be closed during the installation!

1. Create an opening in the wall. Bend the fixing bracket 90°. Place the damper in the opening up to the wall limit mark on the damper.

2. Fix the damper to the wall using screws (bracket screw hole is 6 mm in diameter).

3. Fill the space between the damper and the wall with mortar. Cover the mortar with GKF gypsum boards (12,5 mm thick), fix them with self-tapping screws Ø3,5x45 mm.

*Multiple fire dampers can be installed next to each other or ceiling/wall with the minimal distance of 30 mm between them, [see page 17](#).

Test the operation of the damper blade!

Flexible wall installation (mortar sealing without cover boards)

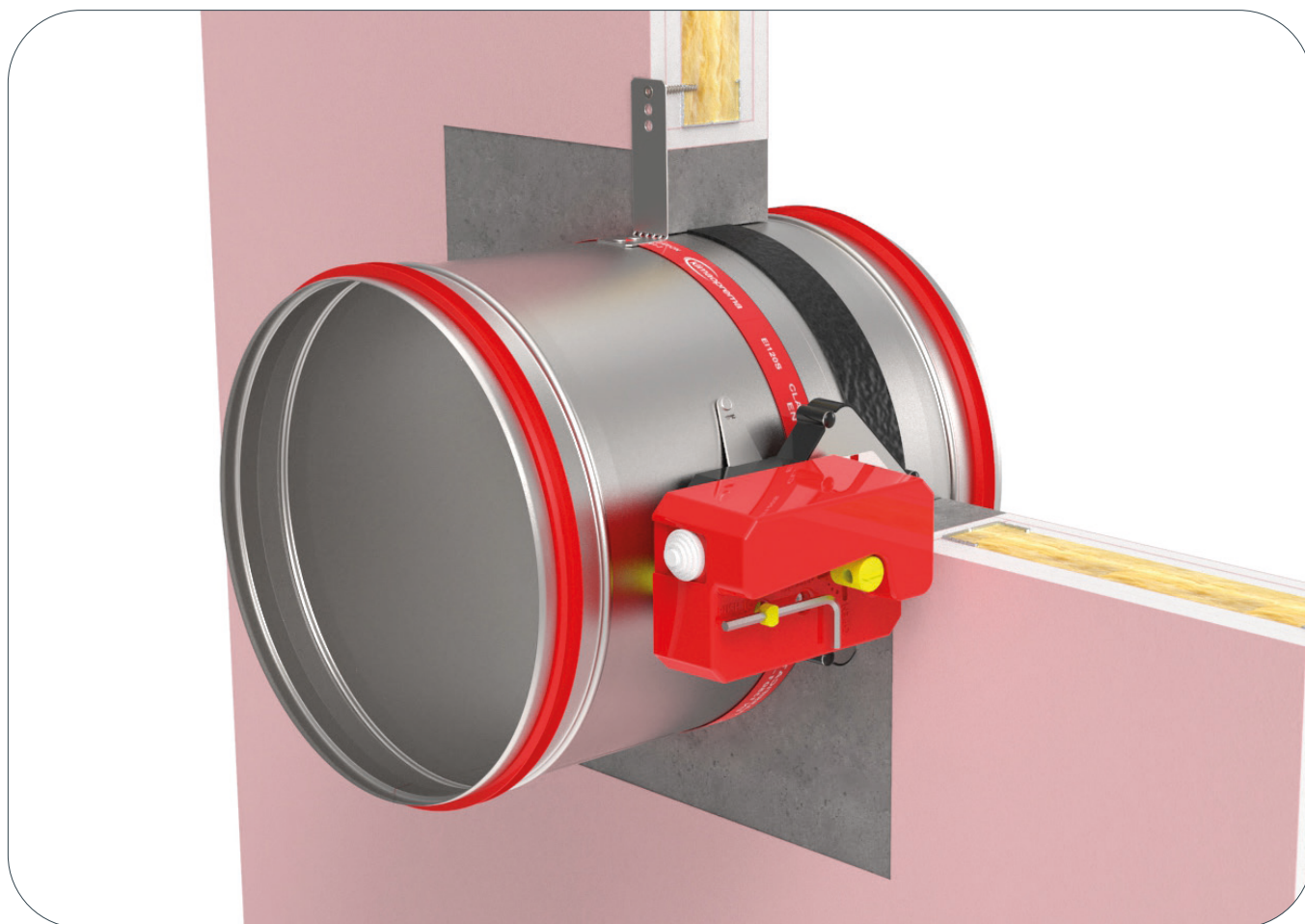

The wall is composed of 2x2 plasterboard boards, 12,5 mm thick, installed on a steel frame construction. Installation material: gypsum plaster or mortar. The minimum thickness of the wall is 100 mm.

EI 120 (ve i↔o)S - FDC 40

The wall is made out of type F (EN520) gypsum plaster boards. To fulfill the classification it is **NOT** mandatory to use the mineral wool inside the wall (mineral wool with density up to 100 kg/m³ can be used).

EI 60 (ve i↔o)S - FDC 25

The wall is made out of type A (EN520) gypsum plaster boards. To fulfill the classification it is **NOT** mandatory to use the mineral wool inside the wall (mineral wool with density up to 60 kg/m³ can be used).

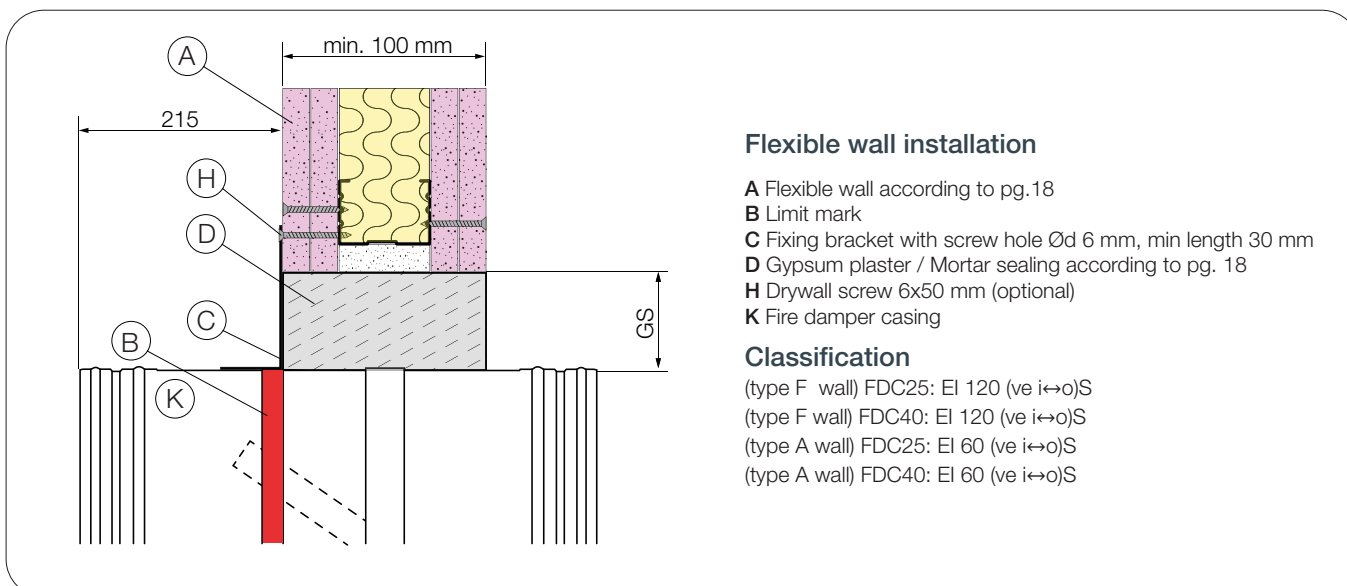



DOP



WALLS



MATERIALS

Possible damper orientations

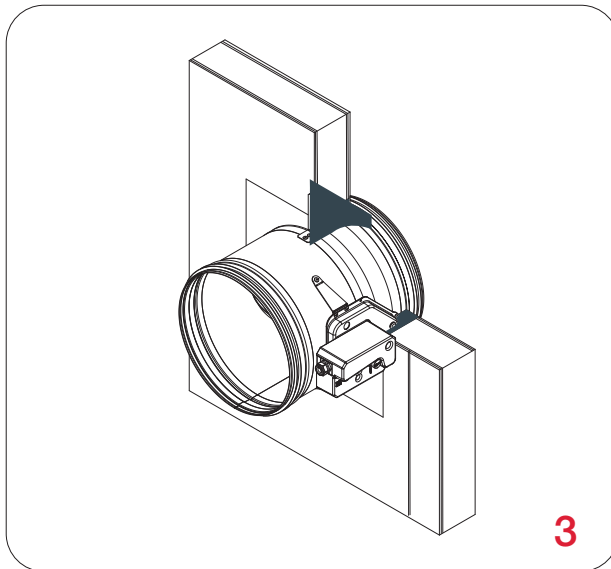
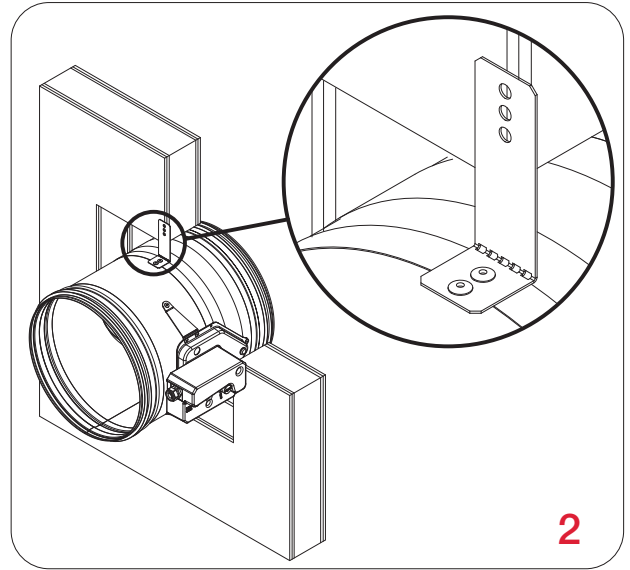
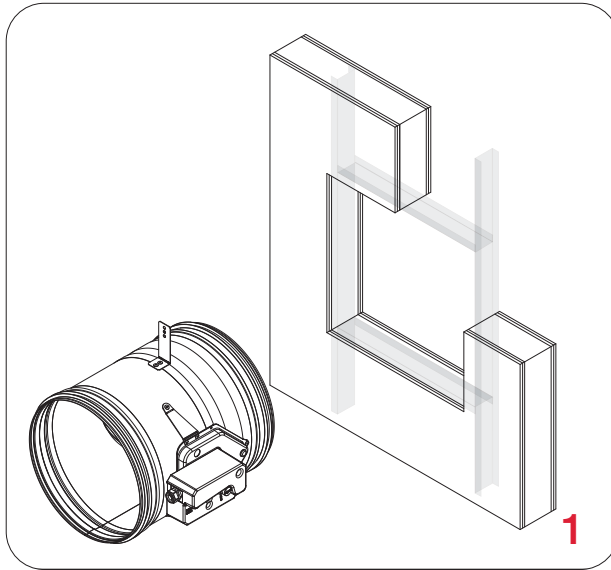

Damper size- Ød [mm]	Gap size - GS
100	55 mm
125	52,5 mm
160	47,5 mm
200	45 mm
250	42,5 mm
315	40 mm
355	40 mm
400	37,5 mm
450	37,5 mm
500	35 mm
560	35 mm
630	35 mm
710	32,5 mm
800	32,5 mm

Damper blade must be closed during the installation!

1. Create an opening in the wall and build the subframe according to the drawing, [see page 16](#). Bend the fixing bracket 90°. Place the damper in the opening up to the wall limit mark on the damper.
2. Fix the damper to the wall using screws (bracket screw hole is 6 mm in diameter).
3. Fill the space between the damper and the wall with mortar.

*Multiple fire dampers can be installed next to each other or ceiling/wall with the minimal distance of 30 mm between them, [see page 17](#).

Test the operation of the damper blade!

Flexible wall installation (mortar sealing)

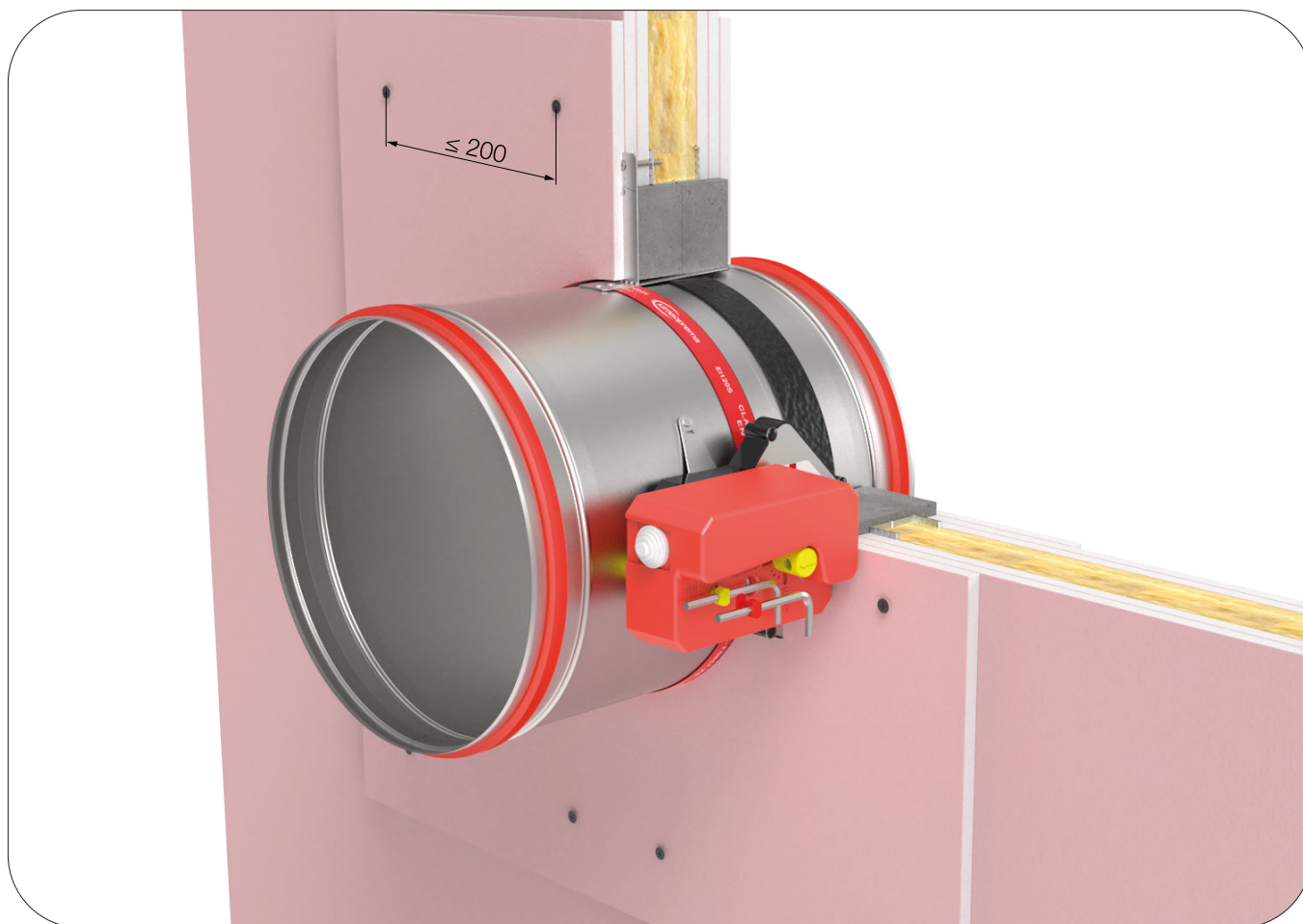

The wall is composed of 2x2 plasterboard boards, 12,5 mm thick, installed on a steel frame construction. Installation material: gypsum plaster or mortar covered with type F(EI 120) or type A(EI 60) cover boards. The minimum thickness of the wall is 100 mm.

EI 120 (ve i↔o)S

The wall is made out of type F (EN520) gypsum plaster boards. To fulfill the classification it is **NOT** mandatory to use the mineral wool inside the wall (mineral wool with density up to 100 kg/m³ can be used).

EI 60 (ve i↔o)S

The wall is made out of type A (EN520) gypsum plaster boards. To fulfill the classification it is **NOT** mandatory to use the mineral wool inside the wall

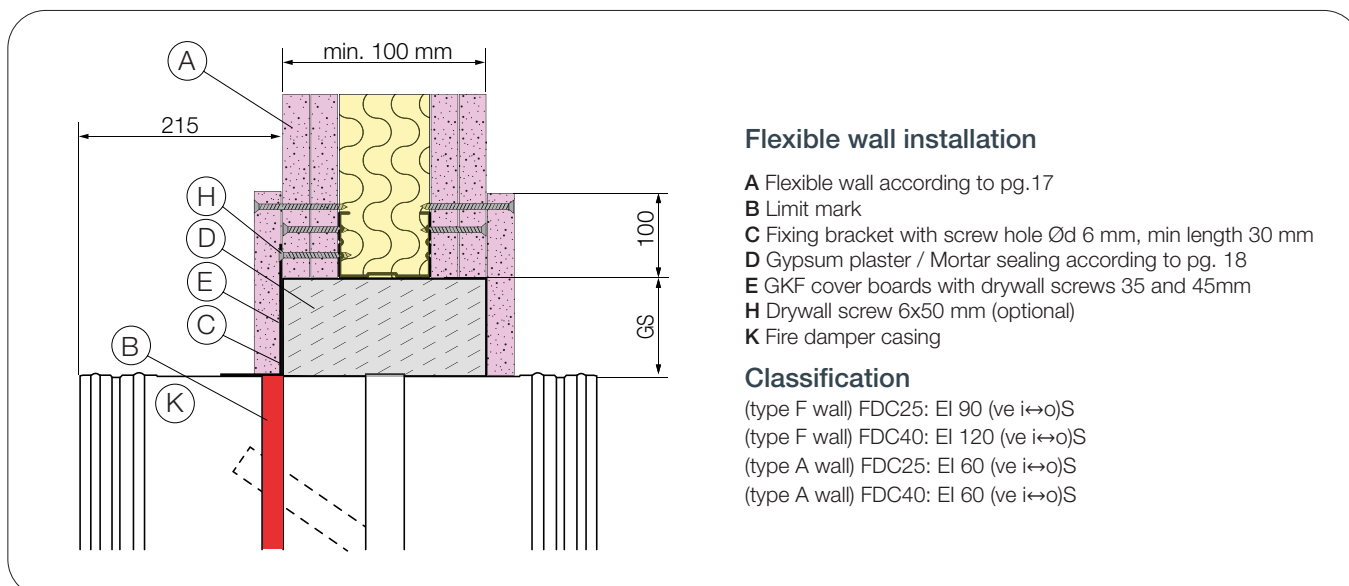



DOP



WALLS



MATERIALS

Possible damper orientations

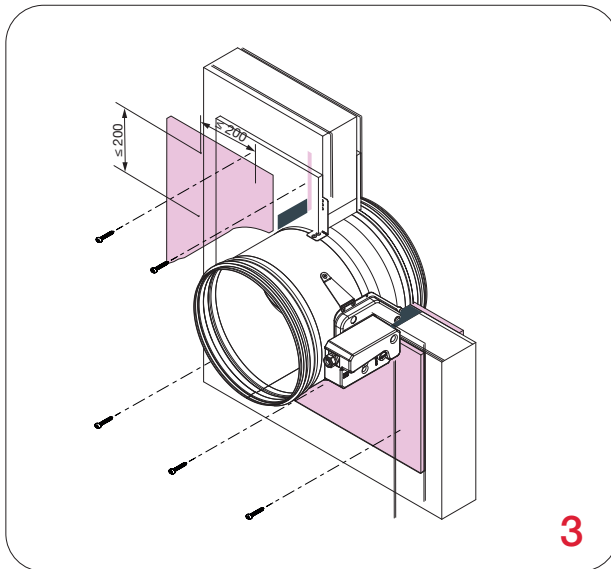
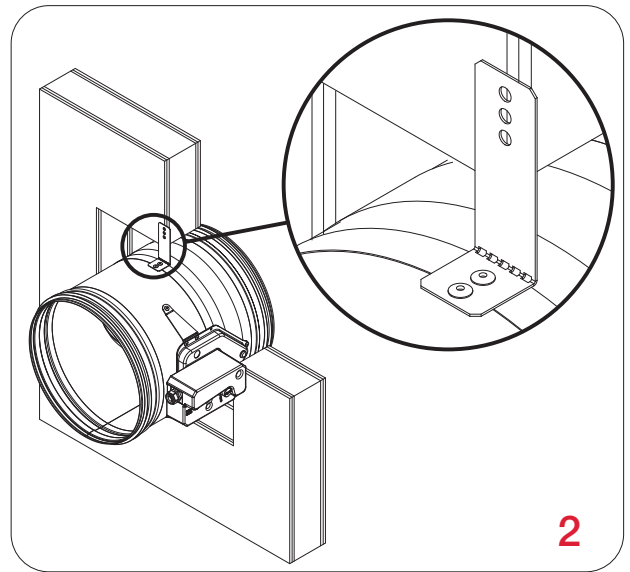
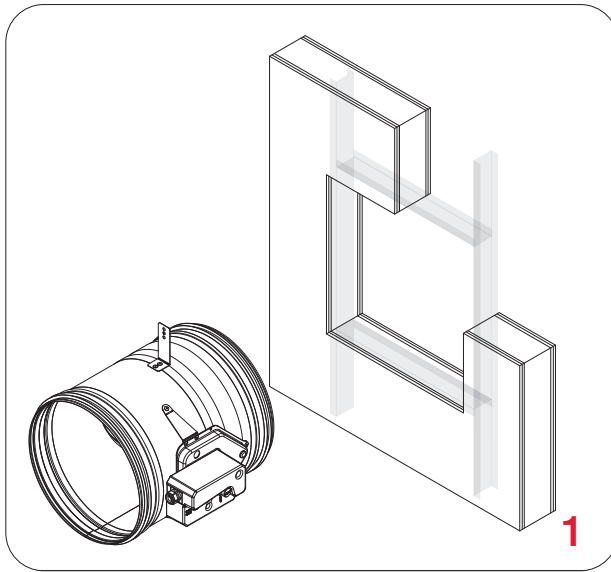

Damper size- Ød [mm]	Gap size - GS
100	55 mm
125	52,5 mm
160	47,5 mm
200	45 mm
250	42,5 mm
315	40 mm
355	40 mm
400	37,5 mm
450	37,5 mm
500	35 mm
560	35 mm
630	35 mm
710	32,5 mm
800	32,5 mm

Damper blade must be closed during the installation!

1. Create an opening in the wall and build the subframe according to the drawing, [see page 16](#). Bend the fixing bracket 90°. Place the damper in the opening up to the wall limit mark on the damper.
2. Fix the damper to the wall using screws (bracket screw hole is 6 mm in diameter).
3. Fill the space between the damper and the wall with mortar . Cover the mortar with GKF gypsum boards (12,5 mm thick), fix them with self-tapping screws Ø3,5x45 mm.

*Multiple fire dampers can be installed next to each other or ceiling/wall with the minimal distance of 30 mm between them, [see page 17](#).

Test the operation of the damper blade!

Flexible wall installation (mineral wool sealing)

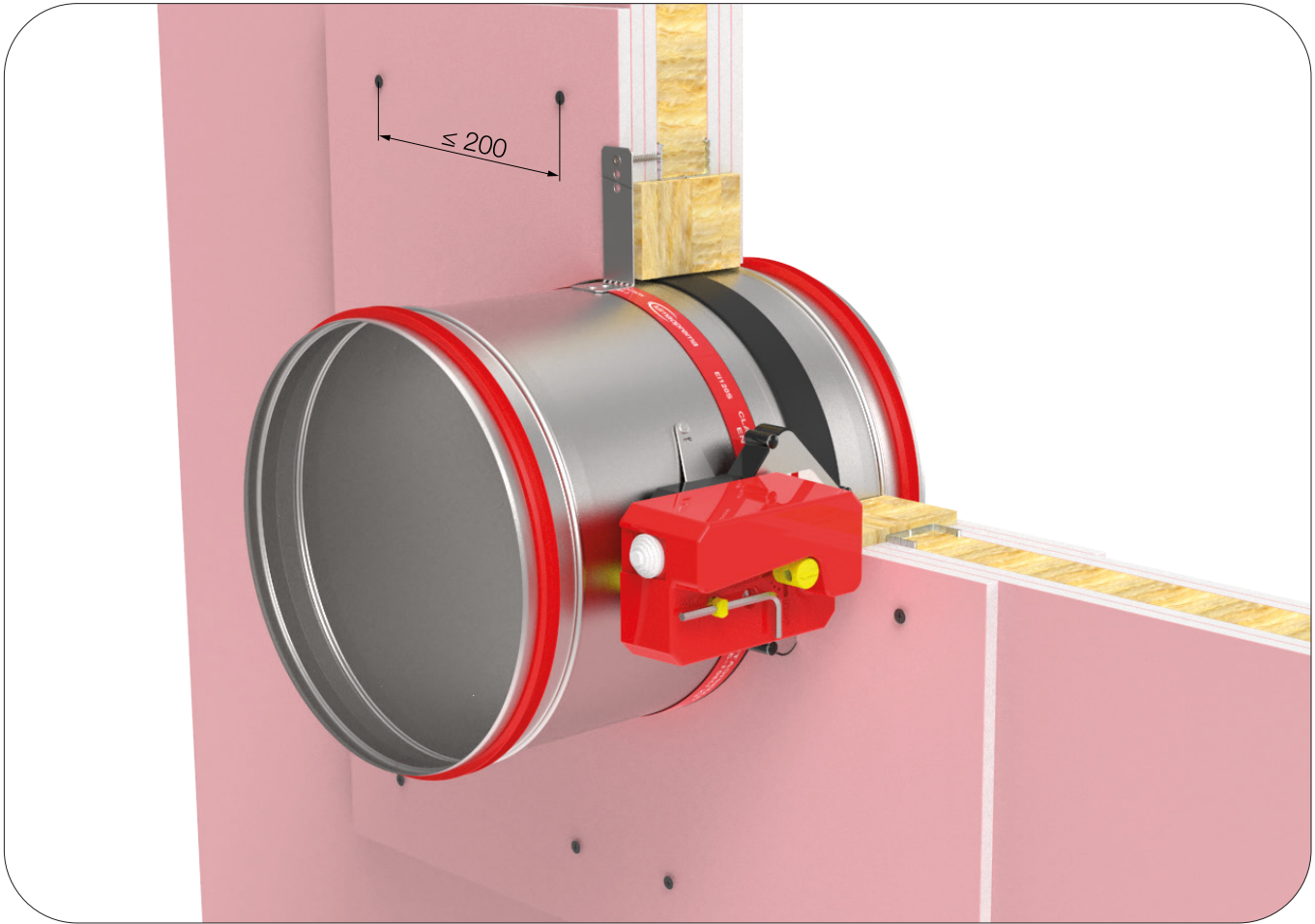

The wall is composed of 2x2 plasterboard boards, 12,5 mm thick, installed on a steel frame construction. Installation material: mineral wool (C) (minimum density of 100 kg/m³) covered with type F (EI 90) or type A (EI 60) cover boards. The minimum thickness of the wall is 100 mm.

EI 90 (ve i↔o)S

The wall is made out of type F (EN520) gypsum plaster boards. To fulfill the classification it is NOT mandatory to use the mineral wool inside the wall (mineral wool with density up to 100 kg/m³ can be used).

EI 60 (ve i↔o)S

The wall is made out of type A (EN520) gypsum plaster boards. To fulfill the classification it is NOT mandatory to use the mineral wool inside the wall (mineral wool with density up to 40 kg/m³ can be used).

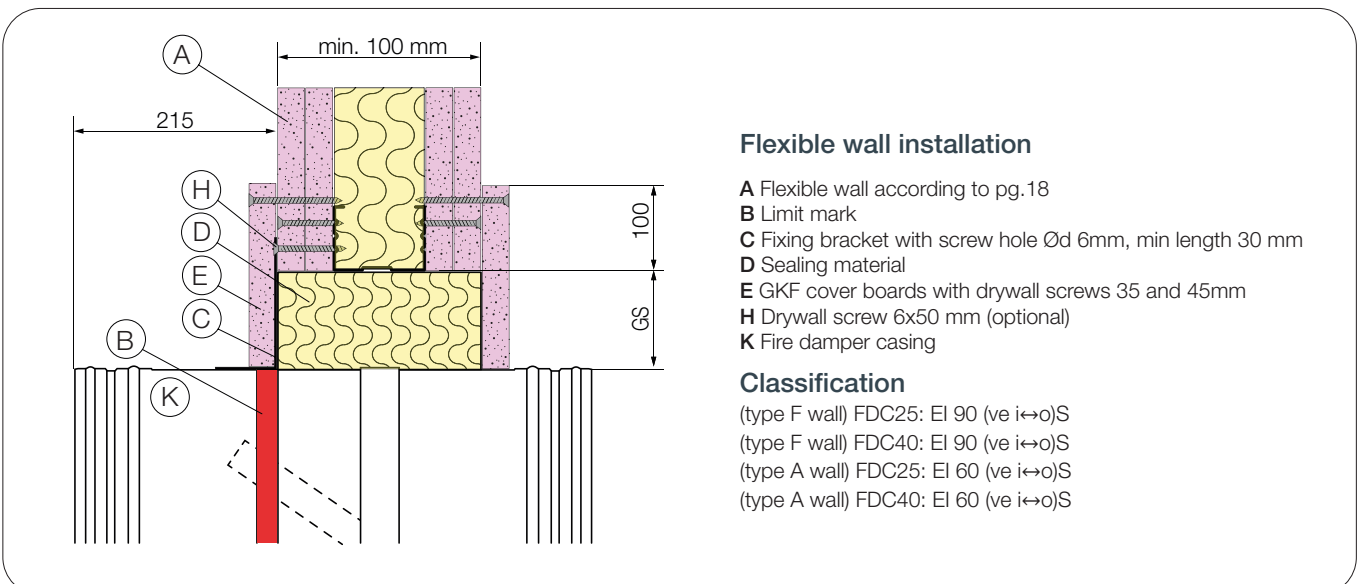

Flexible wall installation

- A Flexible wall according to pg.18
- B Limit mark
- C Fixing bracket with screw hole Ød 6mm, min length 30 mm
- D Sealing material
- E GKF cover boards with drywall screws 35 and 45mm
- H Drywall screw 6x50 mm (optional)
- K Fire damper casing

Classification

- (type F wall) FDC25: EI 90 (ve i↔o)S
- (type F wall) FDC40: EI 90 (ve i↔o)S
- (type A wall) FDC25: EI 60 (ve i↔o)S
- (type A wall) FDC40: EI 60 (ve i↔o)S



DOP



WALLS



MATERIALS

Possible damper orientations

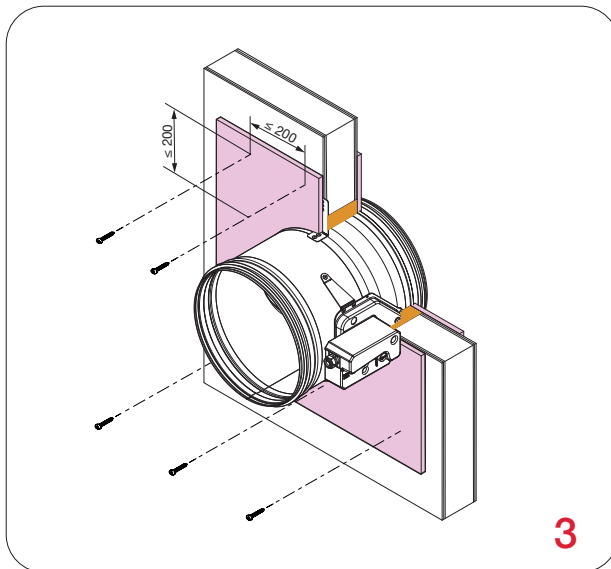
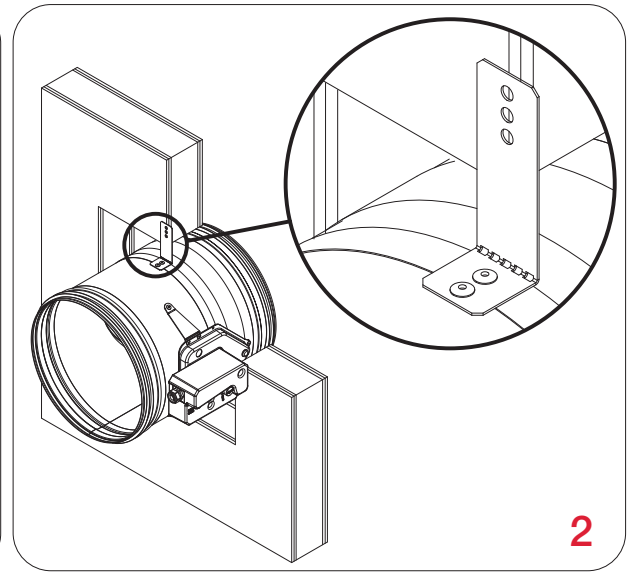
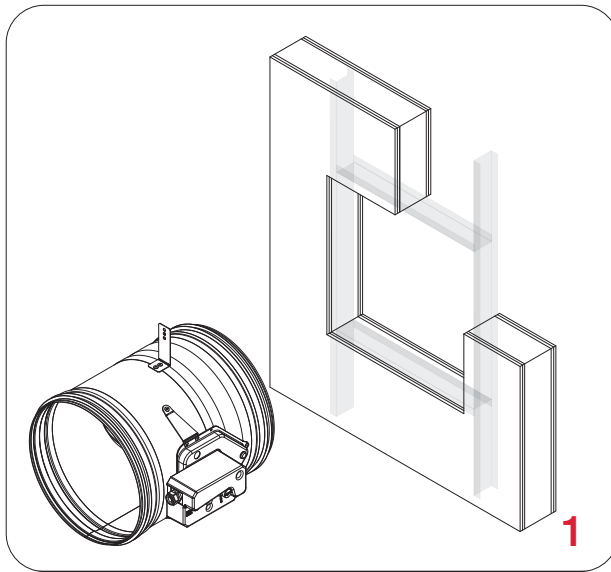

Damper size- Ød [mm]	Gap size - GS
100	55 mm
125	52,5 mm
160	47,5 mm
200	45 mm
250	42,5 mm
315	40 mm
355	40 mm
400	37,5 mm
450	37,5 mm
500	35 mm
560	35 mm
630	35 mm
710	32,5 mm
800	32,5 mm

Damper blade must be closed during the installation!

1. Create an opening in the wall and build the subframe according to the drawing, [see page 16](#). Bend the fixing bracket 90°. Place the damper in the opening up to the wall limit mark on the damper.
2. Fix the damper to the wall using screws (bracket screw hole is 6 mm in diameter).
3. Fill the space between the damper and the wall with mineral wool. Cover the mineral wool with GKF gypsum boards (12,5 mm thick), fix them with self-tapping screws Ø3,5x45 mm.

*Multiple fire dampers can be installed next to each other or ceiling/wall with the minimal distance of 30 mm between them, [see page 17](#).

Test the operation of the damper blade!

Flexible wall installation (Fire Batt/Weichschott)

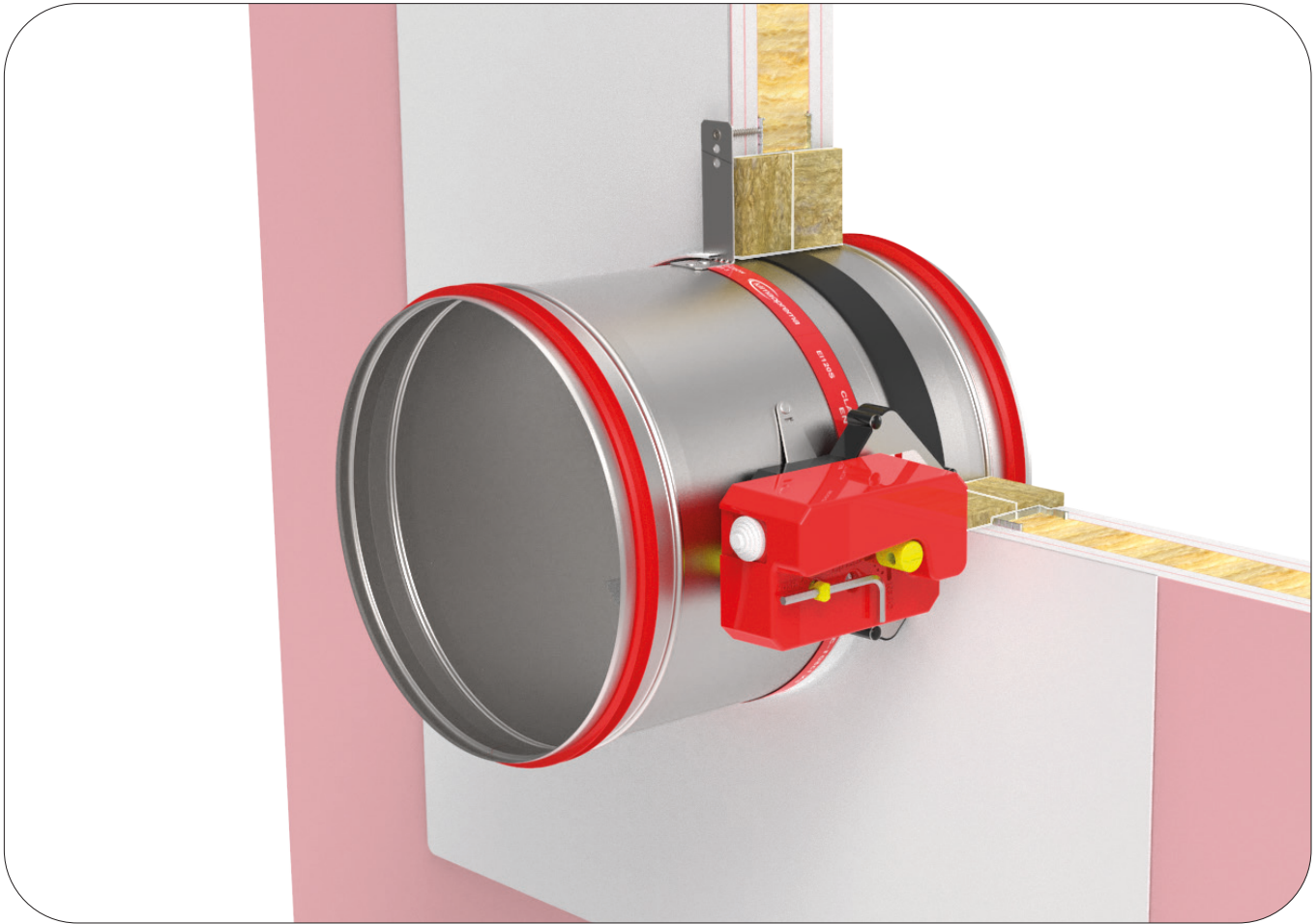

The wall is composed of 2x2 plasterboard boards, 12,5 mm thick, installed on a steel frame construction.

EI 90 (ve i↔o)S

The wall is made out of type F (EN520) gypsum plaster boards. To fulfill the classification it is **NOT** mandatory to use the mineral wool inside the wall (mineral wool with density up to 100 kg/m³ can be used). Installation material: mineral wool (C) (minimum density of 140 kg/m³) and fire protection coating. The minimum thickness of the wall is 100 mm.

EI 60 (ve i↔o)S

The wall is made out of type A (EN520) gypsum plaster boards. To fulfill the classification it is **NOT** mandatory to use the mineral wool inside the wall (mineral wool with density up to 60 kg/m³ can be used). Installation material: mineral wool (C) (minimum density of 140 kg/m³) and fire protection coating. The minimum thickness of the wall is 100 mm.

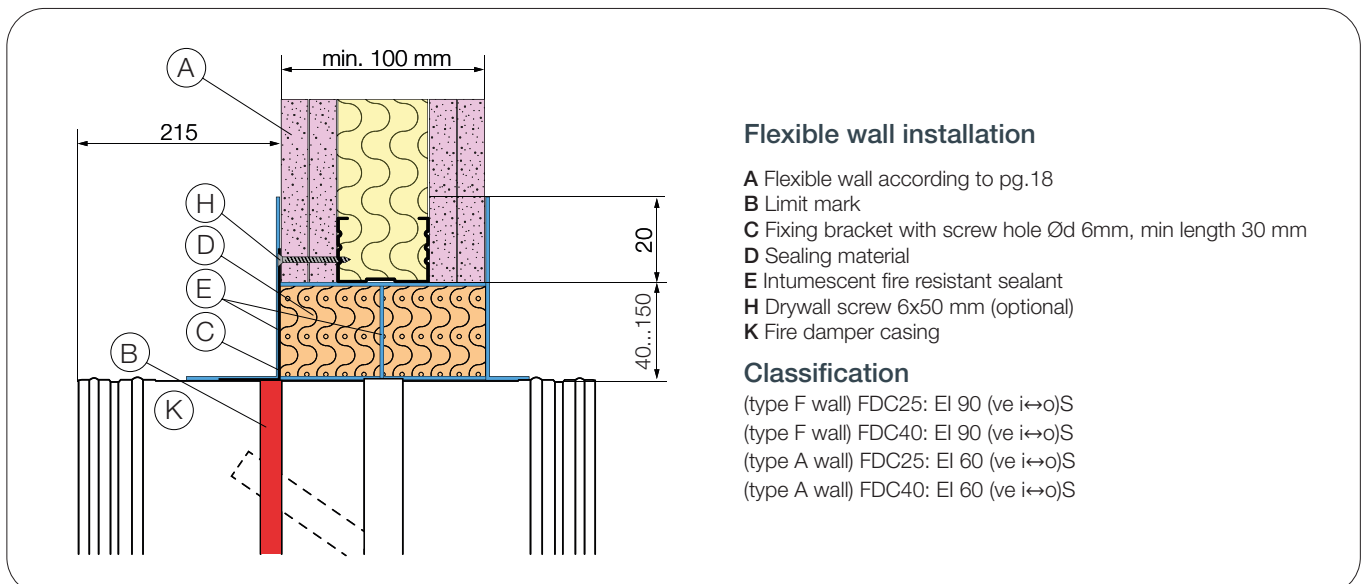



[Video instructions](#)



DOP



WALLS



MATERIALS

Possible damper orientations

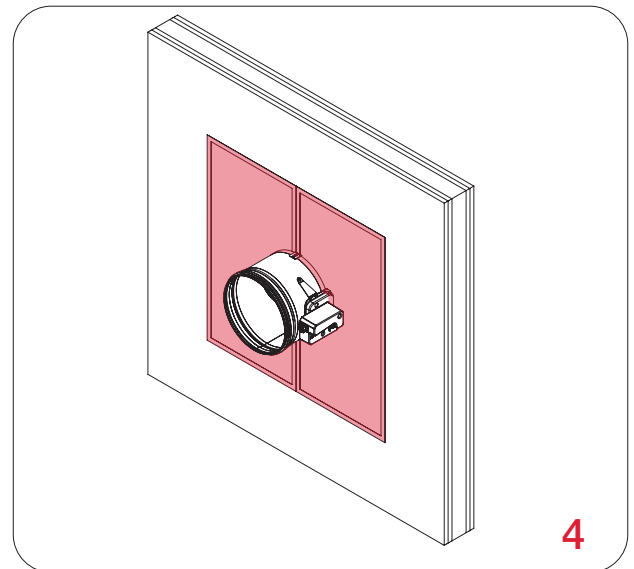
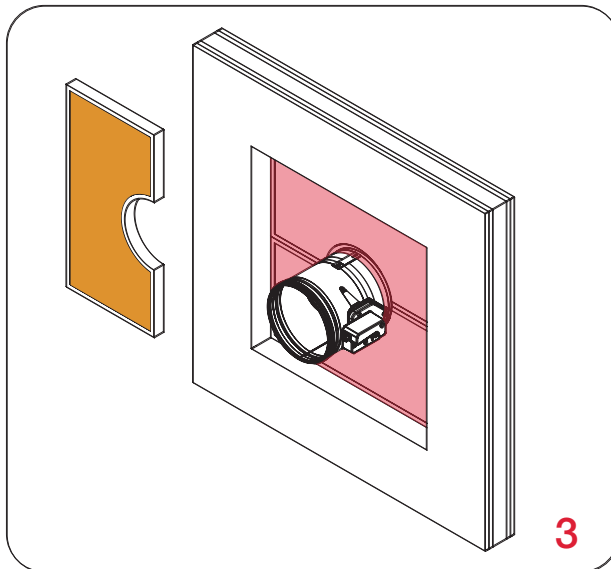
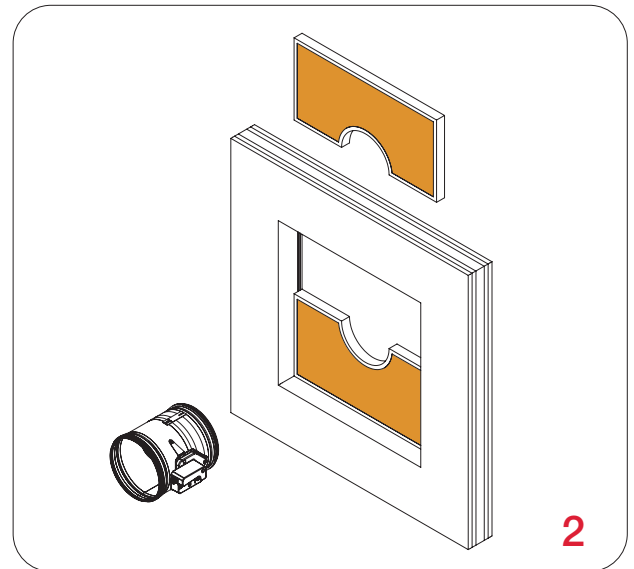
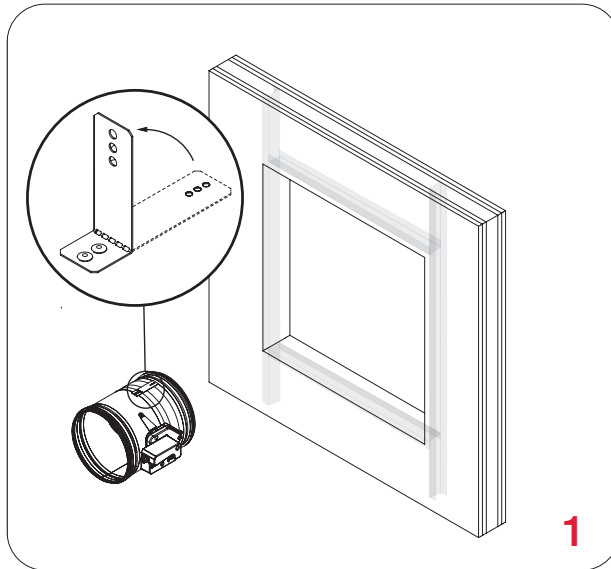

Damper blade must be closed during the installation!

1. Create an opening in the wall ($\varnothing d + 80 \dots 300 \text{ mm}$) \times ($\varnothing d + 80 \dots 300 \text{ mm}$) and build the subframe according to the drawing, [see page 16](#). Bend the mounting bracket by 90° . Insert the damper into the opening up to the wall boundary mark on the damper.
2. Close the gap between the housing and the wall with the first layer of mineral wool (50 mm thick, coated on the inside). Seal the joints between the pieces of mineral wool with intumescent, fire-resistant sealant.
3. Close the gap between the housing and the wall with the second layer of mineral wool (50 mm thick, coated on the inside). The joints between the mineral wool pieces must be sealed with intumescent, fire-resistant sealant.
4. Outside of the mineral wool and the damper housing must be coated with a 2 mm thick fire protection coating. The damper housing should be coated up to the profile projections.

*Multiple fire dampers can be installed next to each other or ceiling/wall with the minimal distance of 30 mm between them, [see page 17](#).

Flexible wall installation - 75 mm (Fire Batt/Weichschott)

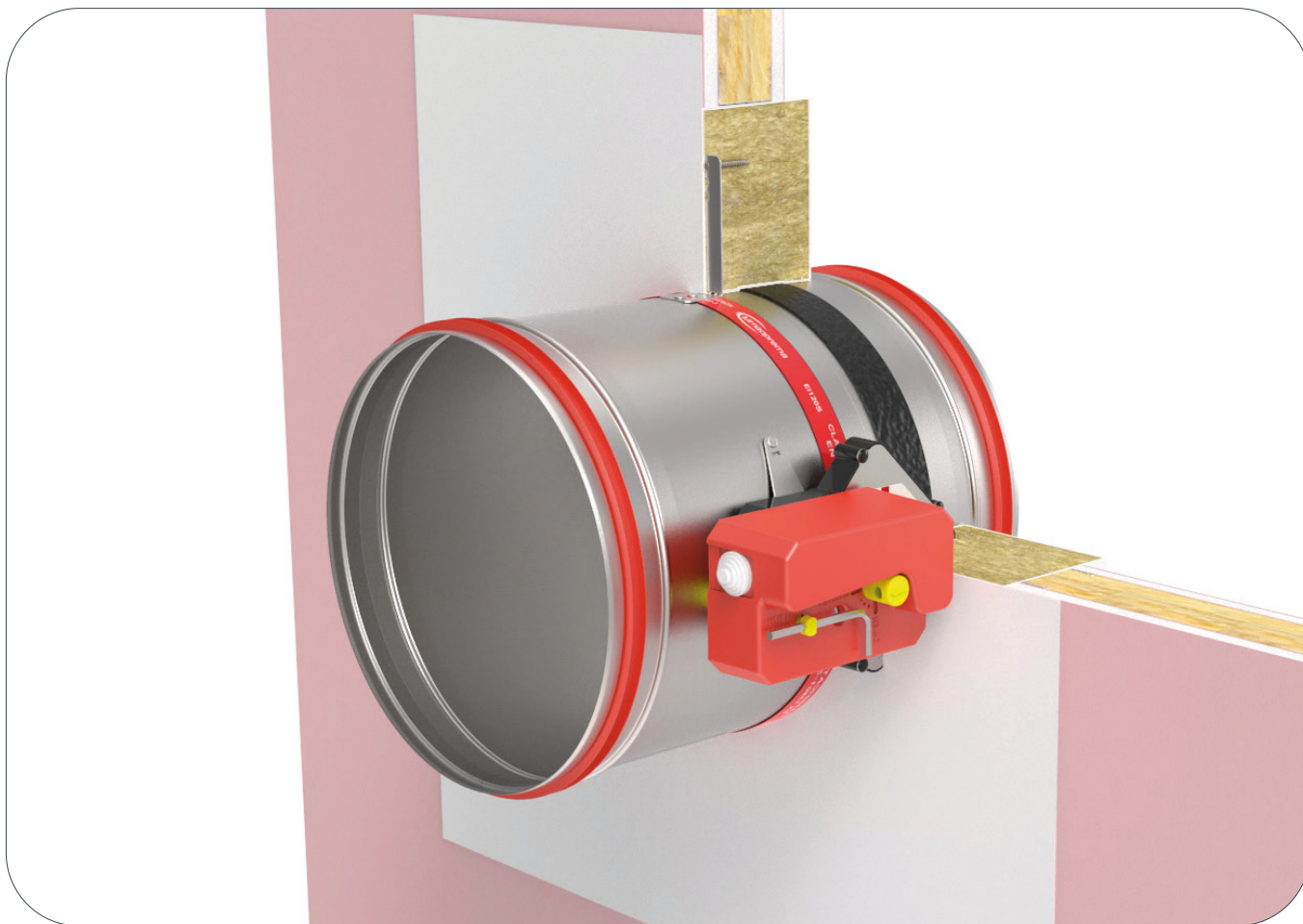

The wall is composed of 1x1 plasterboard boards, 12,5 mm thick, installed on a steel frame construction.

EI 45 (ve i↔o)S

The wall is made out of type F (EN520) gypsum plaster boards. To fulfill the classification it is **NOT** mandatory to use the mineral wool inside the wall (mineral wool with density up to 115 kg/m³ can be used). Installation material: mineral wool (minimum density of 140 kg/m³) and fire protection coating. The minimum thickness of the wall is 75 mm.

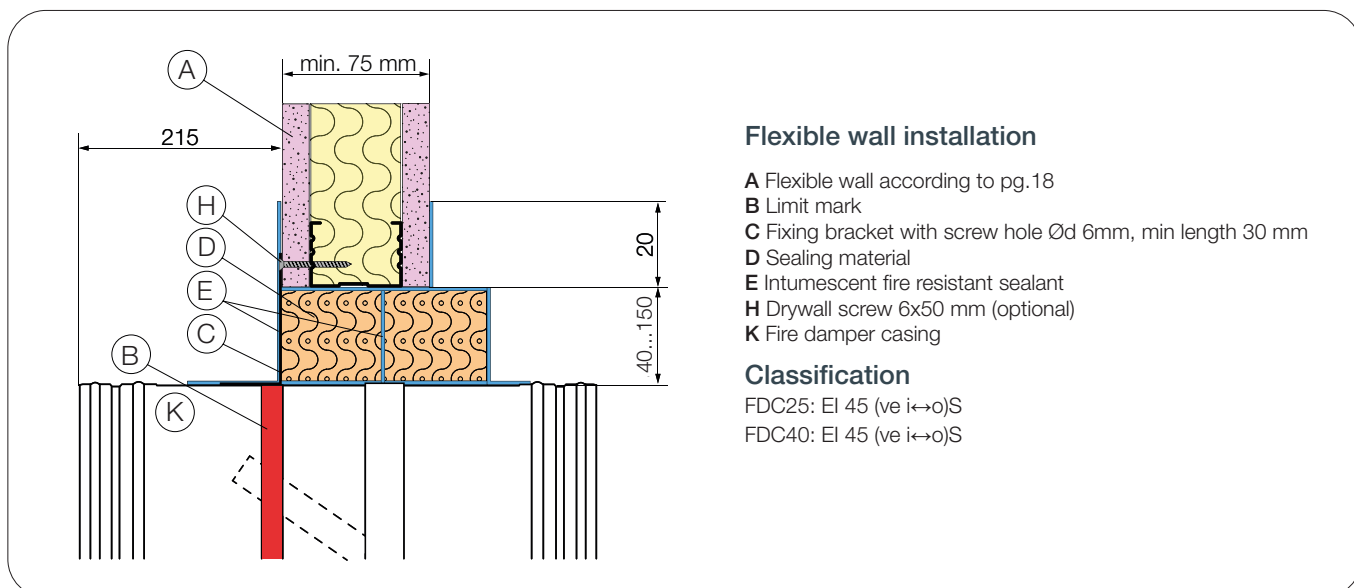



[Video instructions](#)



DOP



WALLS



MATERIALS

Possible damper orientations

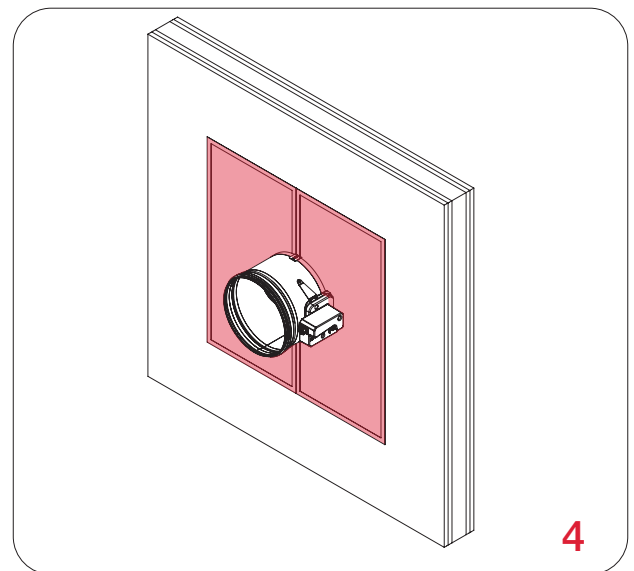
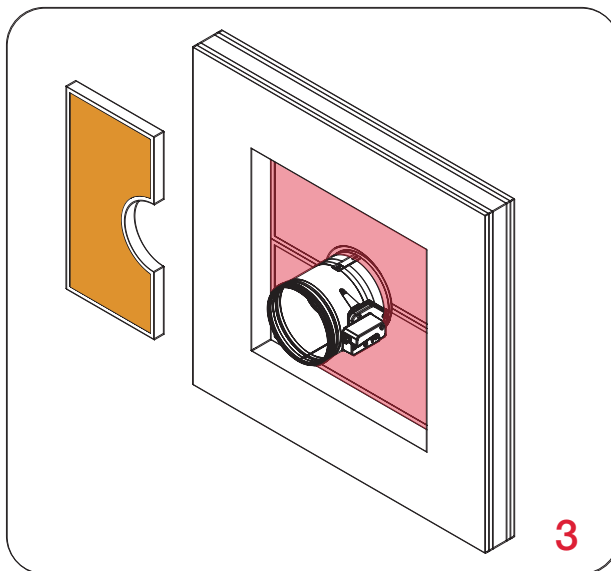
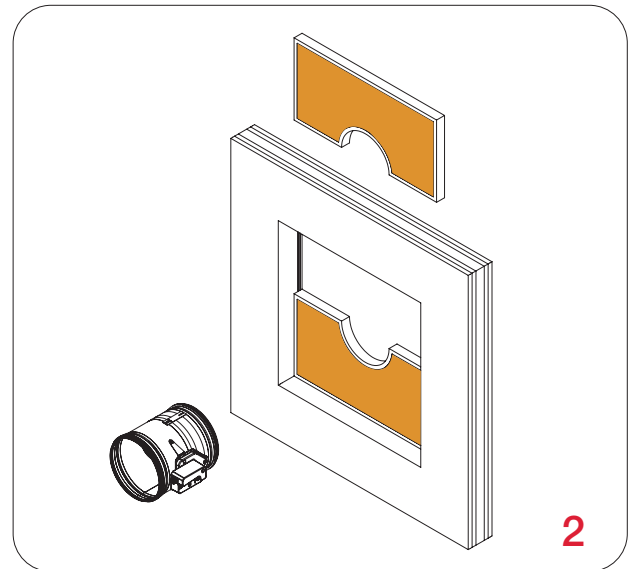
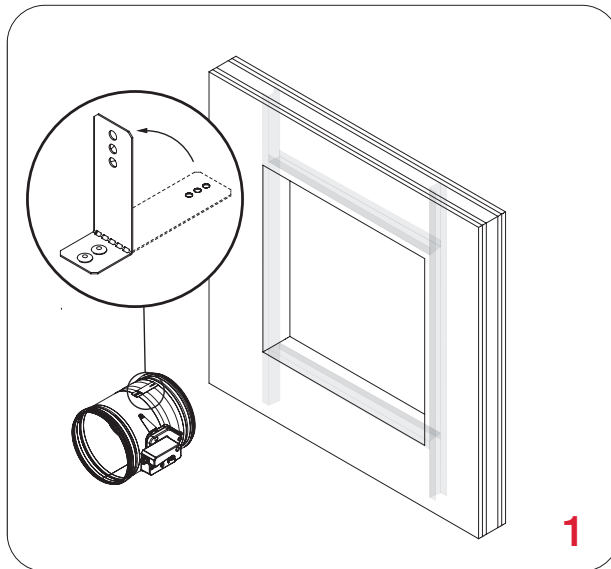

Damper blade must be closed during the installation!

1. Create an opening in the wall ($\text{Ød} + 80 \dots 300 \text{ mm}$) \times ($\text{Ød} + 80 \dots 300 \text{ mm}$) and build the subframe according to the drawing, [see page 16](#). Bend the mounting bracket by 90° . Insert the damper into the opening up to the wall boundary mark on the damper.
2. Close the gap between the housing and the wall with the first layer of mineral wool (50 mm thick, coated on the inside). Seal the joints between the pieces of mineral wool with intumescent, fire-resistant sealant.
3. Close the gap between the housing and the wall with the second layer of mineral wool (50 mm thick, coated on the inside). The joints between the mineral wool pieces must be sealed with intumescent, fire-resistant sealant.
4. Outside of the mineral wool and the damper housing must be coated with a 2 mm thick fire protection coating. The damper housing should be coated up to the profile projections.

*Multiple fire dampers can be installed next to each other or ceiling/wall with the minimal distance of 30 mm between them, [see page 17](#).

Test the operation of the damper blade!

Solid wood wall installation CLT wall (Fire Batt/Weichschott)

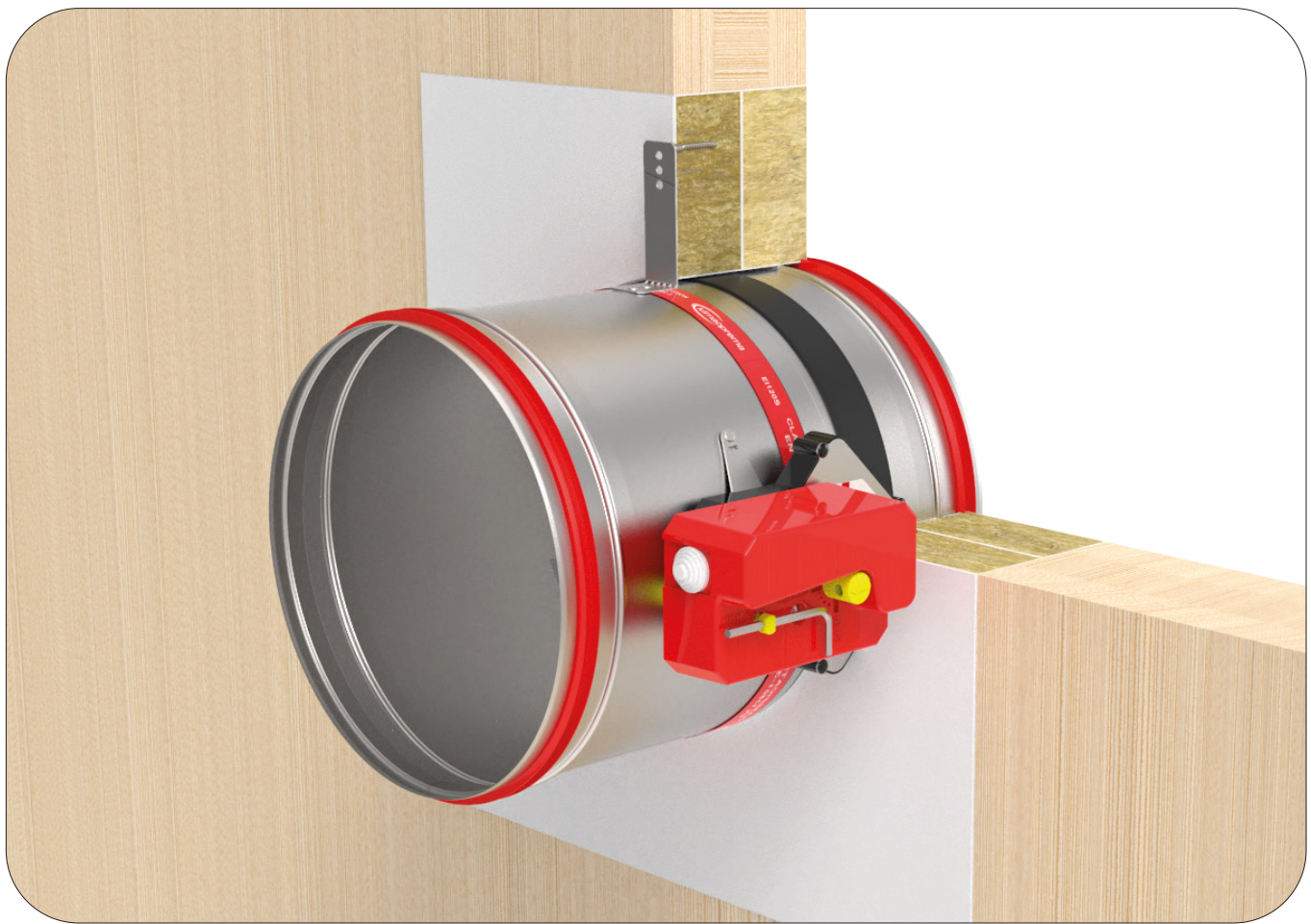

Fire dampers are mounted in CLT (Cross laminated timber) wooden wall with density 480 kg/m^3 . Wall is made of 3 layers (30 – 40 – 30mm).

EI 90 (ve i↔o)S

Installation material: Mineral wool (minimum density of 140 kg/m^3 , fire protection coating).

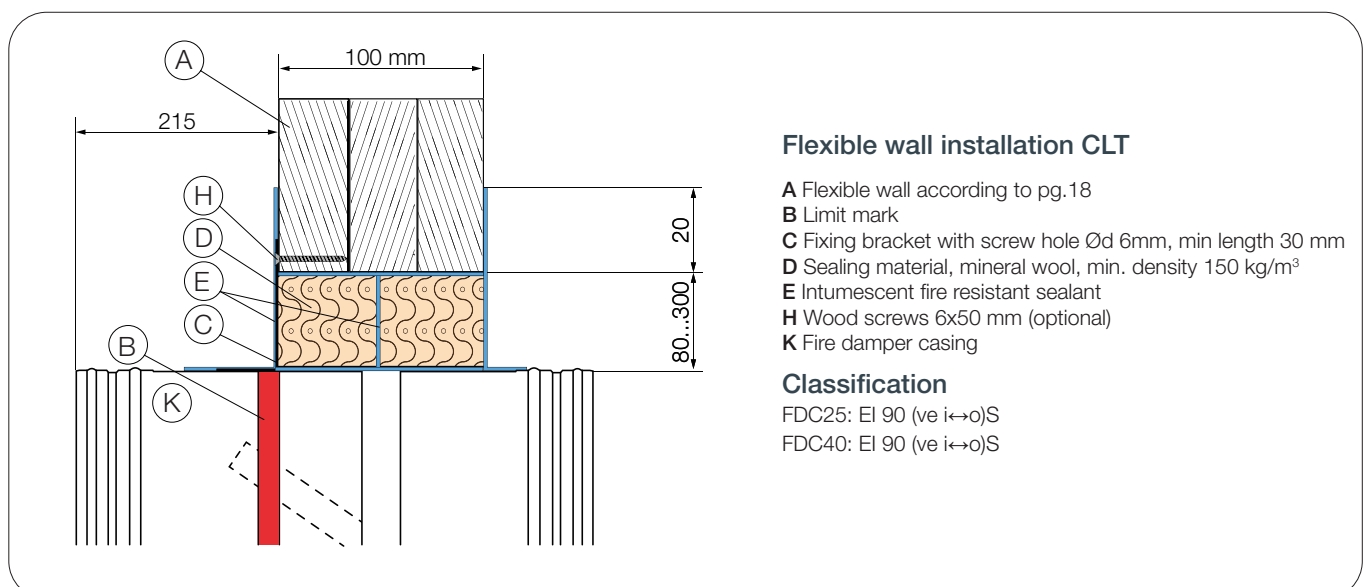



DOP



WALLS



MATERIALS

Possible damper orientations

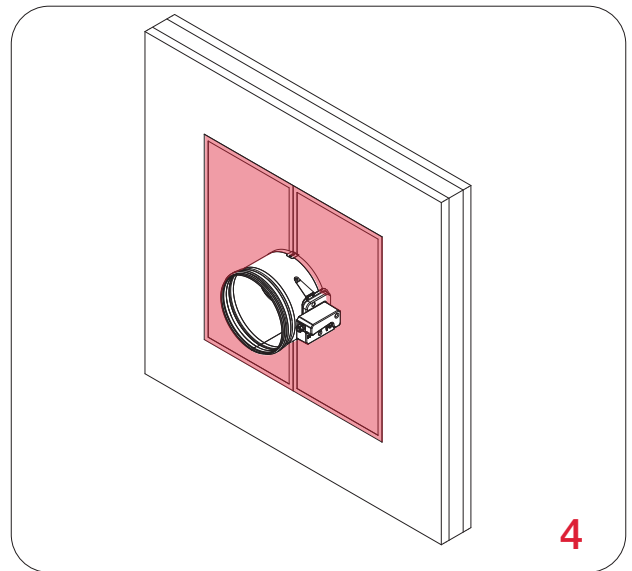
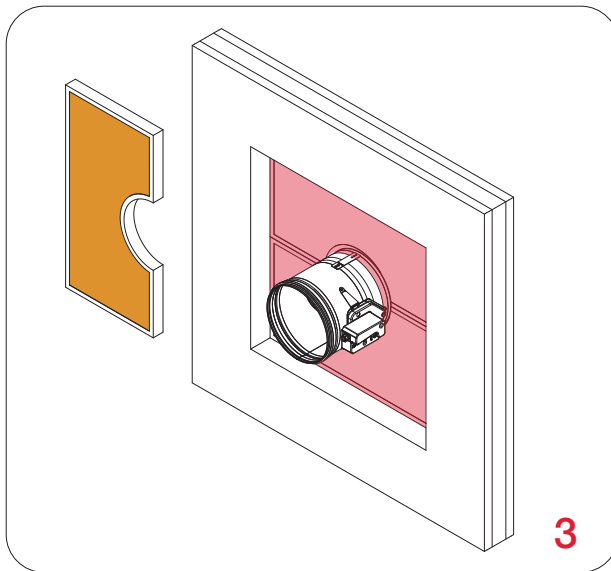
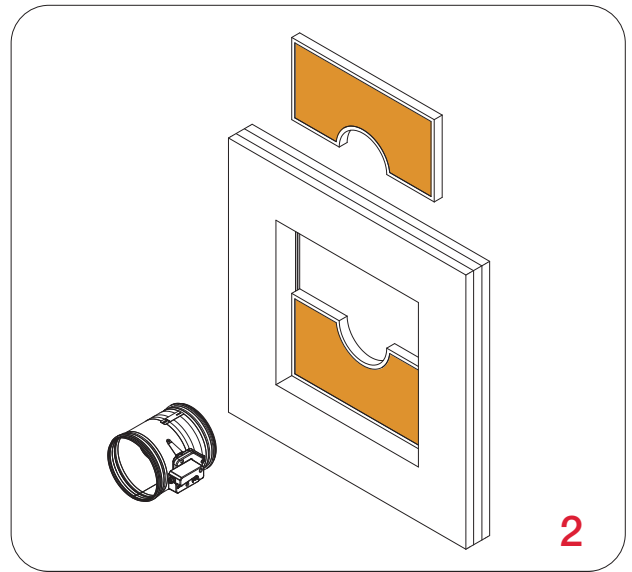
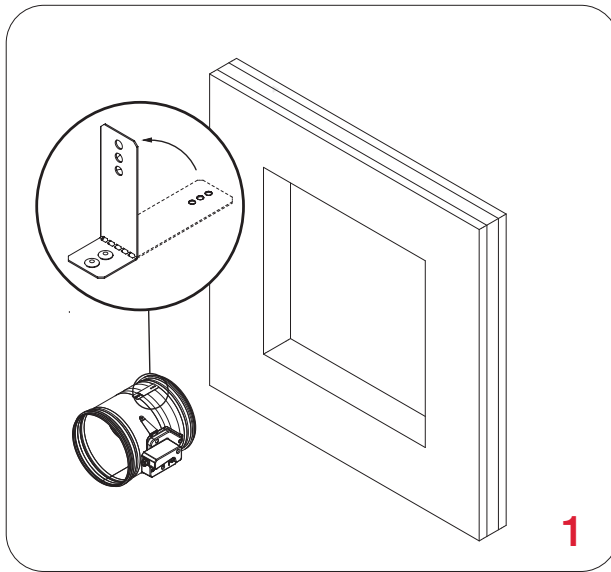

Damper blade must be closed during the installation!

1. Create an opening in the wall ($\varnothing d + 80...300$ mm) x ($\varnothing d + 80...300$ mm). Bend the mounting bracket by 90° . Insert the damper into the opening up to the wall boundary mark on the damper.
2. Close the gap between the housing and the wall with the first layer of mineral wool (50 mm thick, coated on the inside). Seal the joints between the pieces of mineral wool with intumescent, fire-resistant sealant.
3. Close the gap between the housing and the wall with the second layer of mineral wool (50 mm thick, coated on the inside). The joints between the mineral wool pieces must be sealed with intumescent, fire-resistant sealant.
4. Outside of the mineral wool and the damper housing must be coated with a 2 mm thick fire protection coating. The damper housing should be coated up to the profile projections.

*Multiple fire dampers can be installed next to each other or ceiling/wall with the minimal distance of 30 mm between them, [see page 17](#).

Test the operation of the damper blade!

Flexible wall installation Eurobond

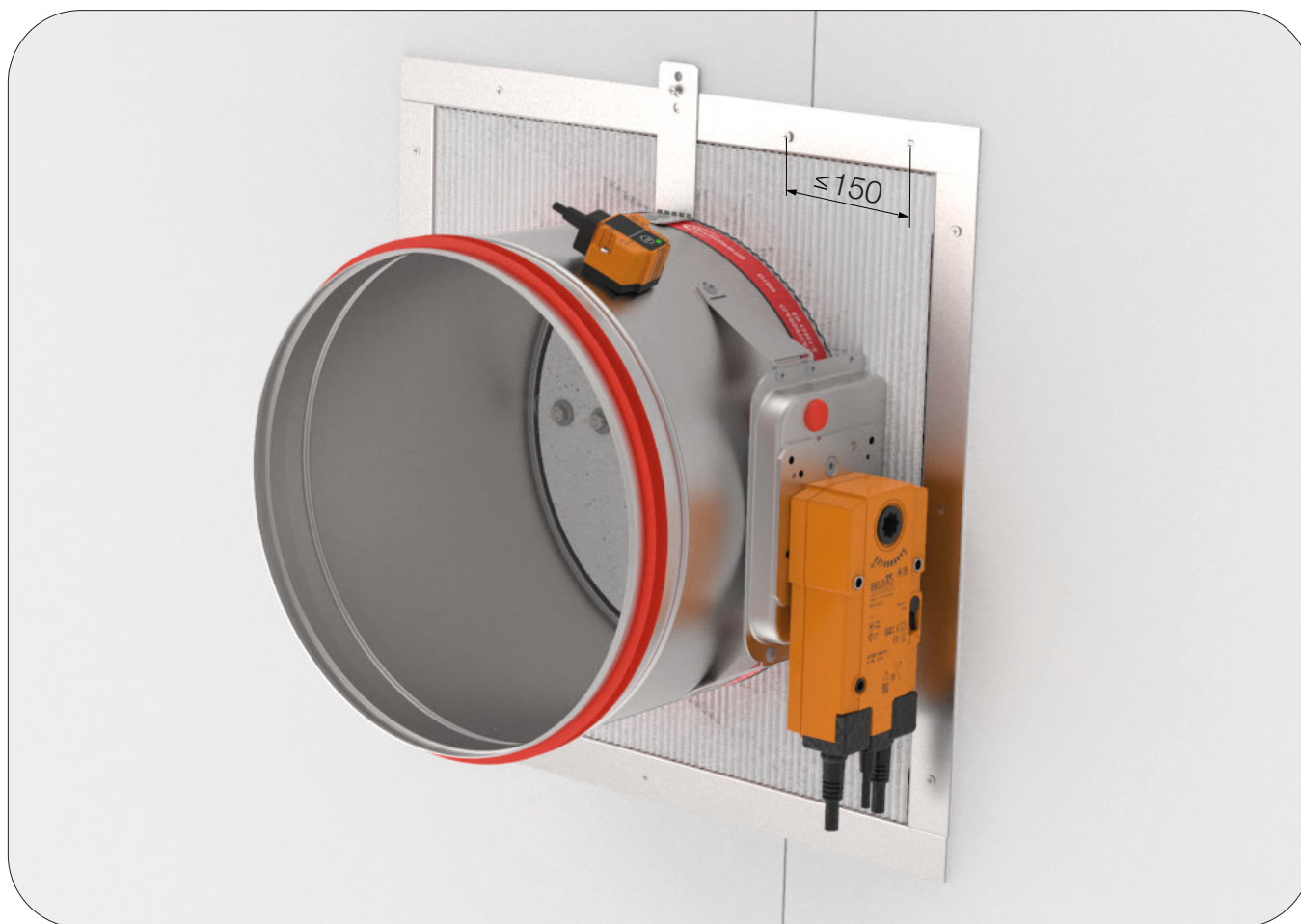

The wall is composed of Eurobond Firemaster boards, in 100 mm thickness, installed in a steel frame construction.

FDC 25 EI 60 (i↔o)S

FDC 40 EI 60 (i↔o)S

Sealing between dampers and wall is 2 layers of Rockwool Firepro 50 mm tick sealed with intumescent fire resistant sealant.

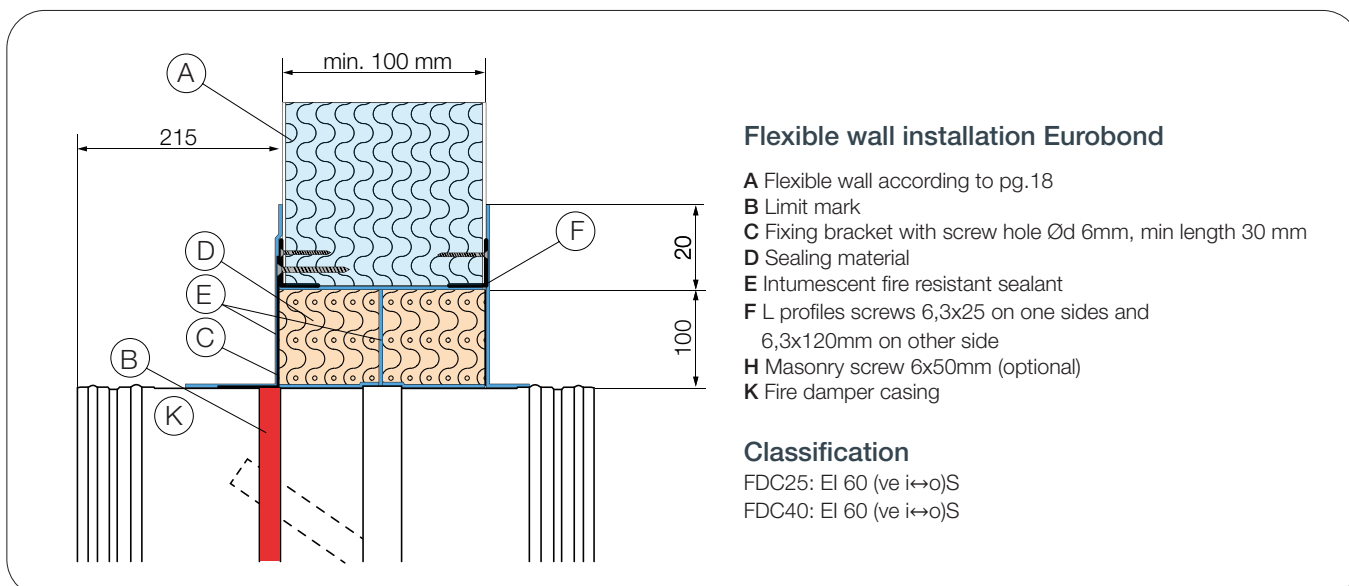



[Technical drawing
of the wall](#)



DOP



WALLS



MATERIALS

Possible
damper
orientations

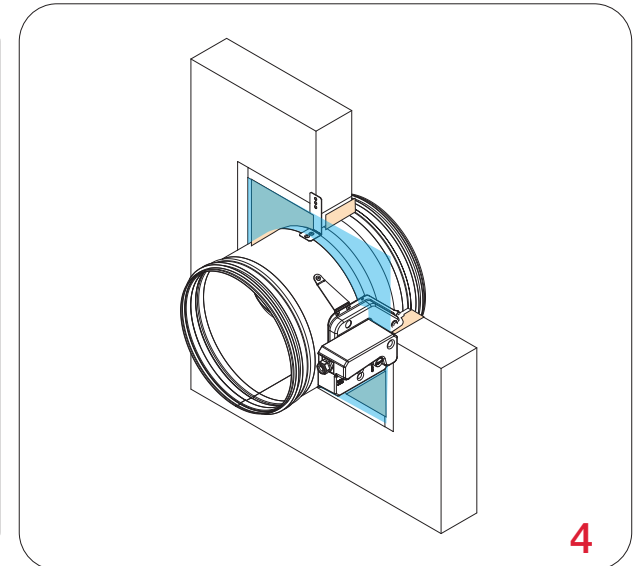
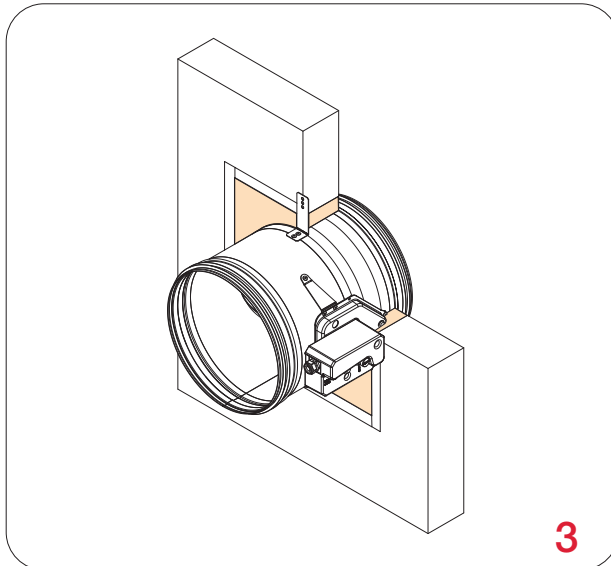
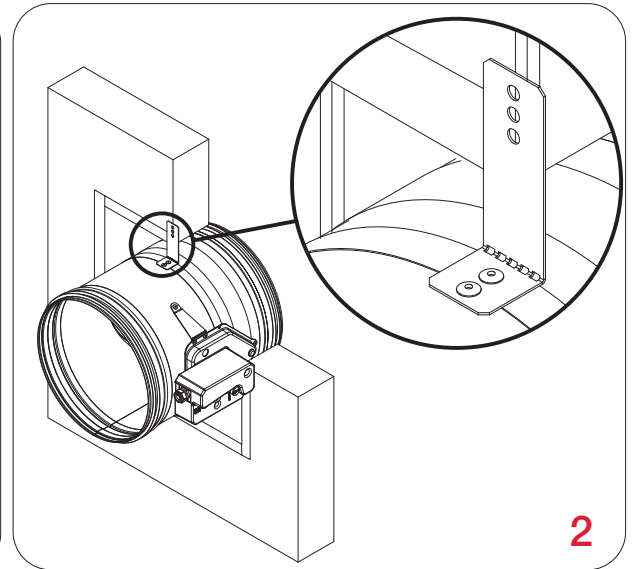
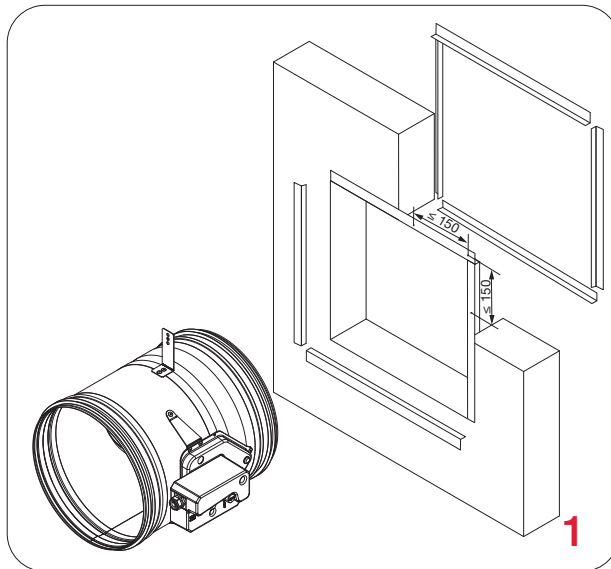

Damper blade must be closed during installation!

Create the wall, see technical drawing.

1. Make the opening in the wall $(d + 100) \times (d + 100)$ mm on the connection of two boards. The opening is re-inforced with L profiles 30x30x2mm and screws 6,3x25 on one sides and 6,3x120mm on other side every 150 mm. The opening in the wall panel must be coated with a 2 mm thick fireproof coating on the inside.
2. Bend the fixing bracket 90°. Place the damper in the opening up to the wall limit mark on the damper.
3. Close the gap between the housing and the wall with two layers of mineral wool (50 mm thick, coated on the inside). Seal the joints between the pieces of mineral wool with intumescent, fire-resistant sealant.
4. Outside of the mineral wool and the damper housing must be coated with a 2 mm thick fire protection coating. The damper housing should be coated up to the profile projections.

*Multiple fire dampers can be installed next to each other or ceiling/wall with the minimal distance of 30 mm between them, [see page 17](#).

Test the operation of the damper blade!

Flexible ceiling joint

Gypsum blocks flexible wall



The wall is composed out of gypsum blocks (minimum density of 450 kg/m^3) and with minimum thickness of 100 mm. Installation material is gypsum plaster and mineral wool (70 kg/m^3), thickness of the wool is 40 mm.

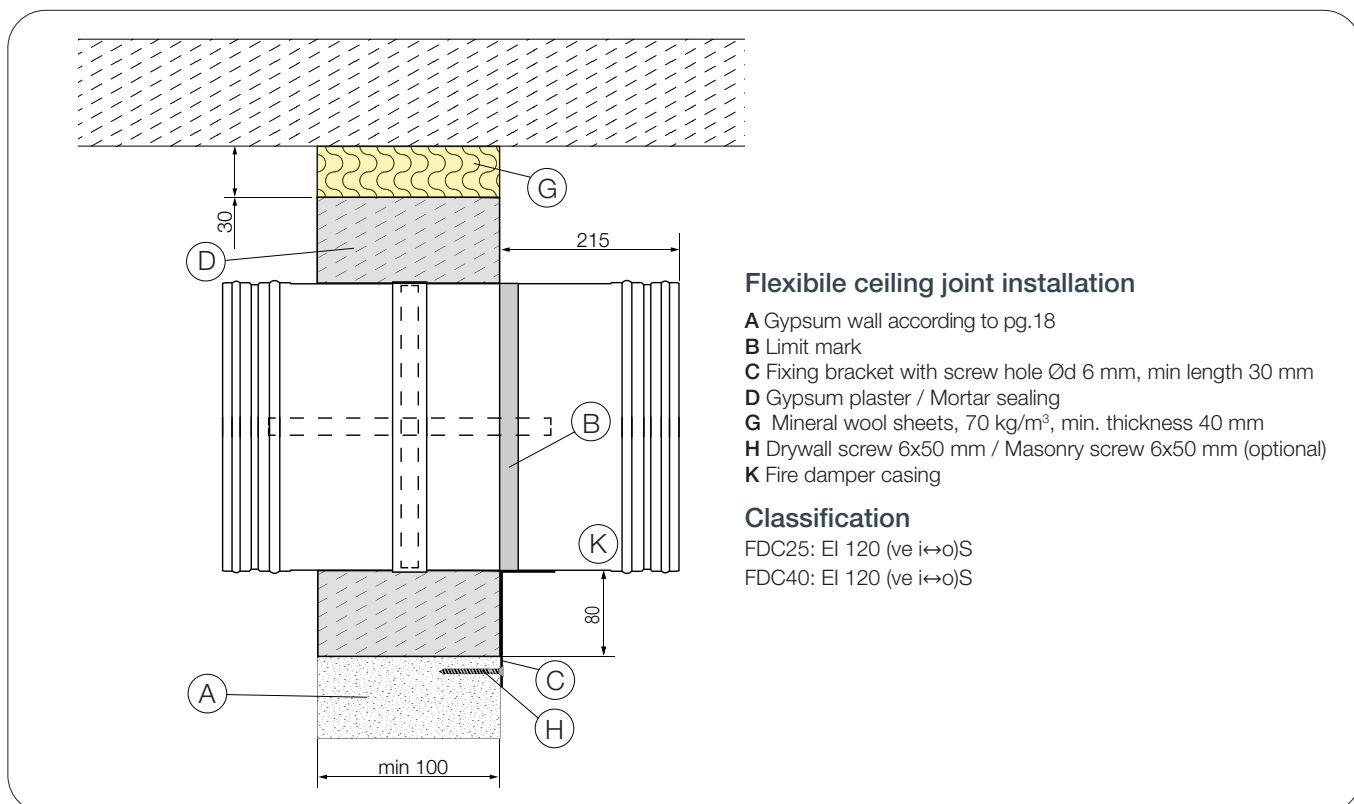



DOP



WALLS



MATERIALS

Possible damper orientations

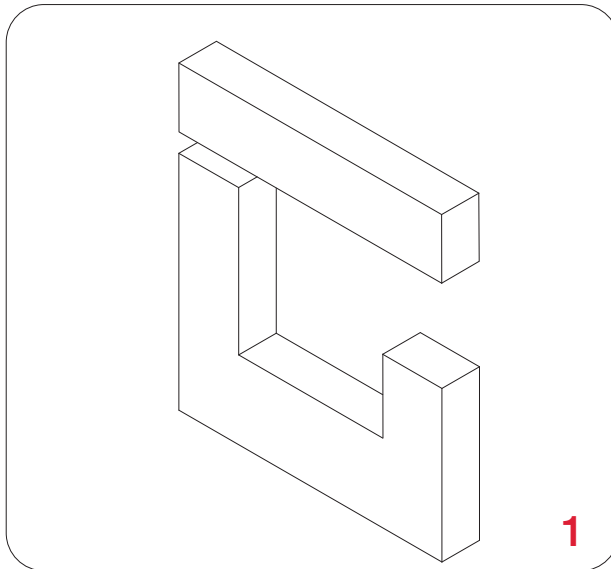

1

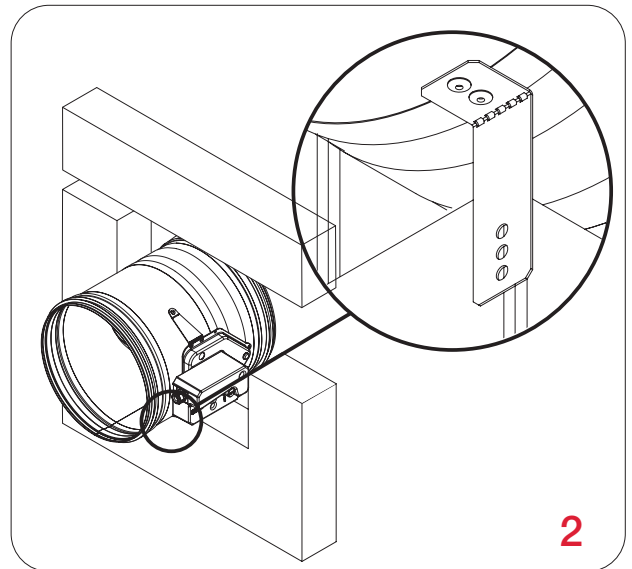

2

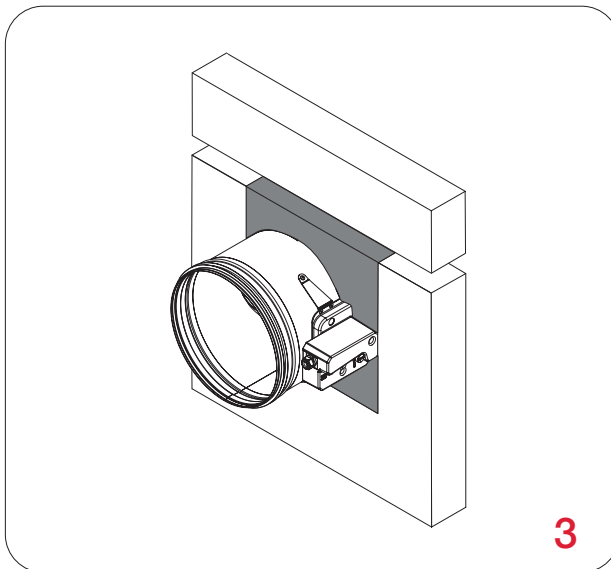

3

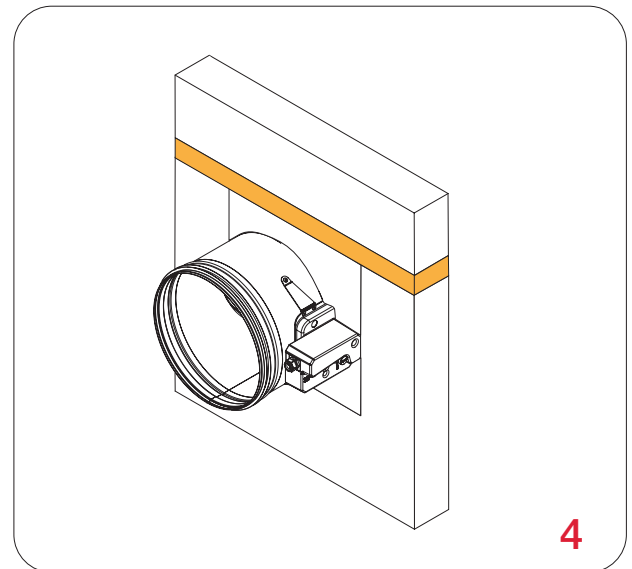

4

Damper blade must be closed during installation!

1. Create an opening in the wall $\text{Ød} + 80 \text{ mm}$, 30mm below the ceiling.
2. Bend the fixing bracket 90° . Insert the fire damper into the opening and fix the mounting bracket with self tapping screw (3,5 x 35 mm)
3. Fill the space between the damper and the wall with gypsum plaster/ mortar.
4. Fill the space between the ceiling and the wall with mineral wool (70 kg/m^3 , thickness 40 mm).

Test the operation of the damper blade!

Flexible ceiling joint

Plasterboard type F flexible wall



The wall is composed of 2x2 plasterboard boards, 12,5 mm thick, installed on a steel frame construction. To fulfill the classification it is **NOT** mandatory to use the mineral wool inside the wall (mineral wool with density up to 100 kg/m³ can be used). The minimum thickness of the wall is 100 mm.

Installation material is gypsum plaster and mineral wool (115 kg/m³), thickness of the wool is 50 mm.

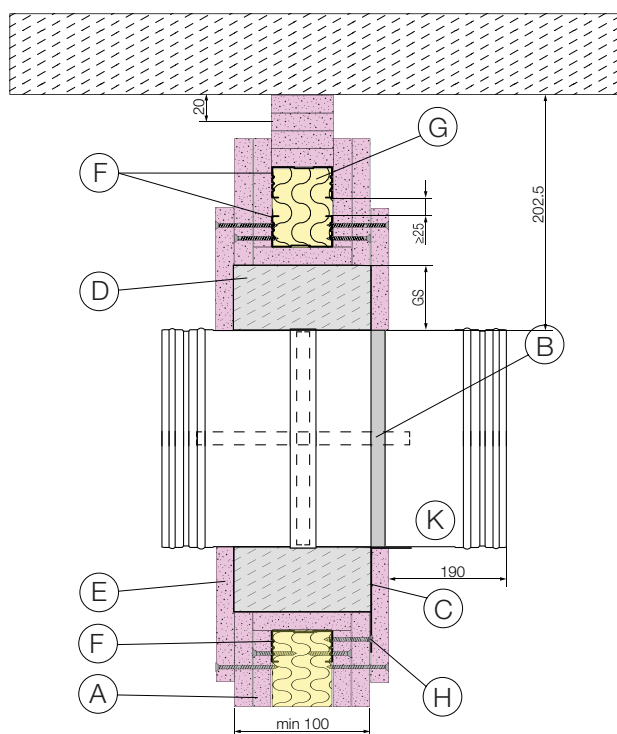

Flexible ceiling joint installation

- A Flexible wall according to pg.18
- B Limit mark
- C Fixing bracket with screw hole Ød 6 mm, min length 30 mm
- D Gypsum plaster / Mortar sealing
- E GKF cover boards with drywall screws 35 and 45mm
- F UW 50 Profile and Mineral wool 50mm, 115 kg/m³
- G Mineral wool sheets, 70 kg/m³, min. thickness 40 mm
- H Drywall screw 6x50 mm / Masonry screw 6x50 mm (optional)
- K Fire damper casing

Classification

FDC25: EI 120 (ve i→o)S

FDC40: EI 120 (ve i→o)S



[Technical drawing of the construction of the wall](#)



[Technical drawing](#)



DOP



WALLS



MATERIALS

Possible damper orientations

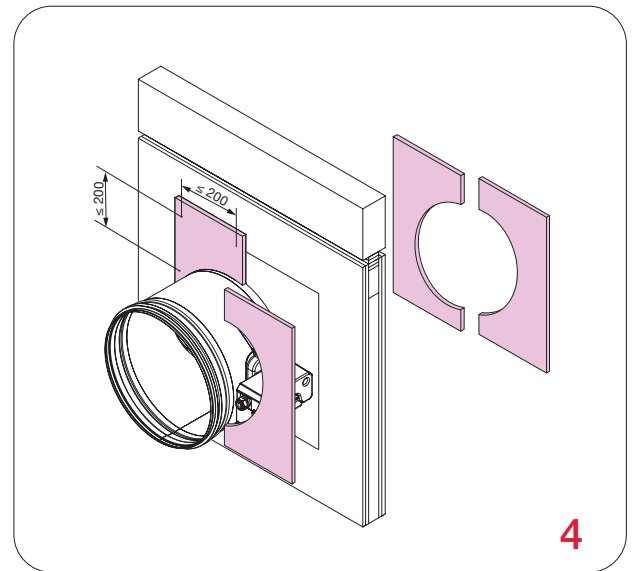
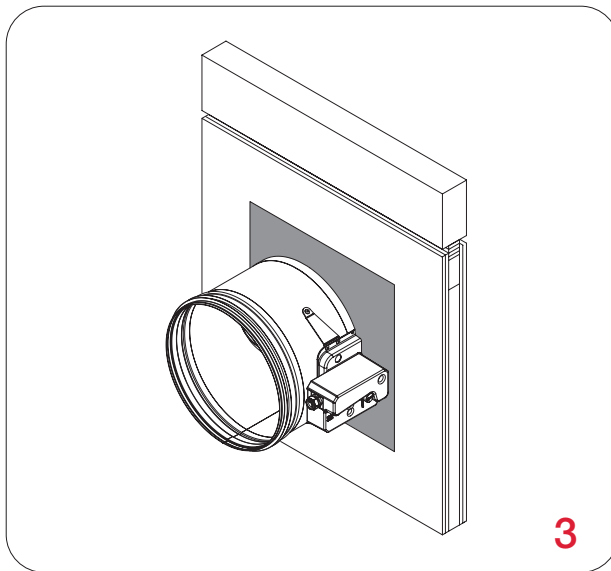
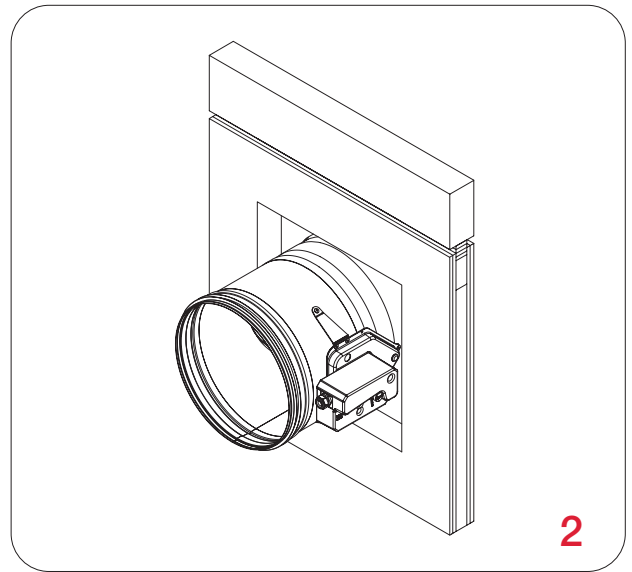
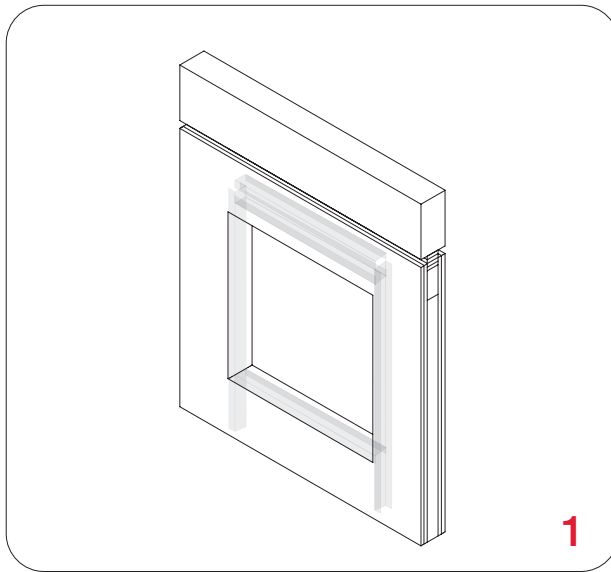

Damper blade must be closed during installation!

1. Prepare subconstruction and cladding of the wall with gypsum boards acc. to technical drawing. Take care that cladding of the wall is not connected to profile connected to the ceiling so it could compensate movement of the ceiling without impact to the wall. Fill the space between the ceiling segment and the wall with mineral wool. Create an opening in the wall.

2. Bend the fixing bracket 90°. Insert the fire damper into the opening and fix the mounting bracket with self tapping screw (3,5 x 35 mm)

3. Fill the space between the damper and the wall with gypsum plaster/ mortar.

4. Cover the mineral wool with GKF gypsum boards (12,5 mm thick), fix them with self-tapping screws Ø3,5x45 mm.

Damper size- Ød [mm]	Gap size - GS
100	55 mm
125	52,5 mm
160	47,5 mm
200	45 mm
250	42,5 mm
315	40 mm
355	40 mm
400	37,5 mm
450	37,5 mm
500	35 mm
560	35 mm
630	35 mm
710	32,5 mm
800	32,5 mm

Test the operation of the damper blade!

Rigid floor/ceiling installation (mortar sealing)



The floor/ceiling is composed of concrete blocks (minimum density of 450 kg/m³) or reinforced concrete (minimum density of 2200 kg/m³) and with a minimum thickness of 100 mm. Installation material is gypsum plaster or mortar.

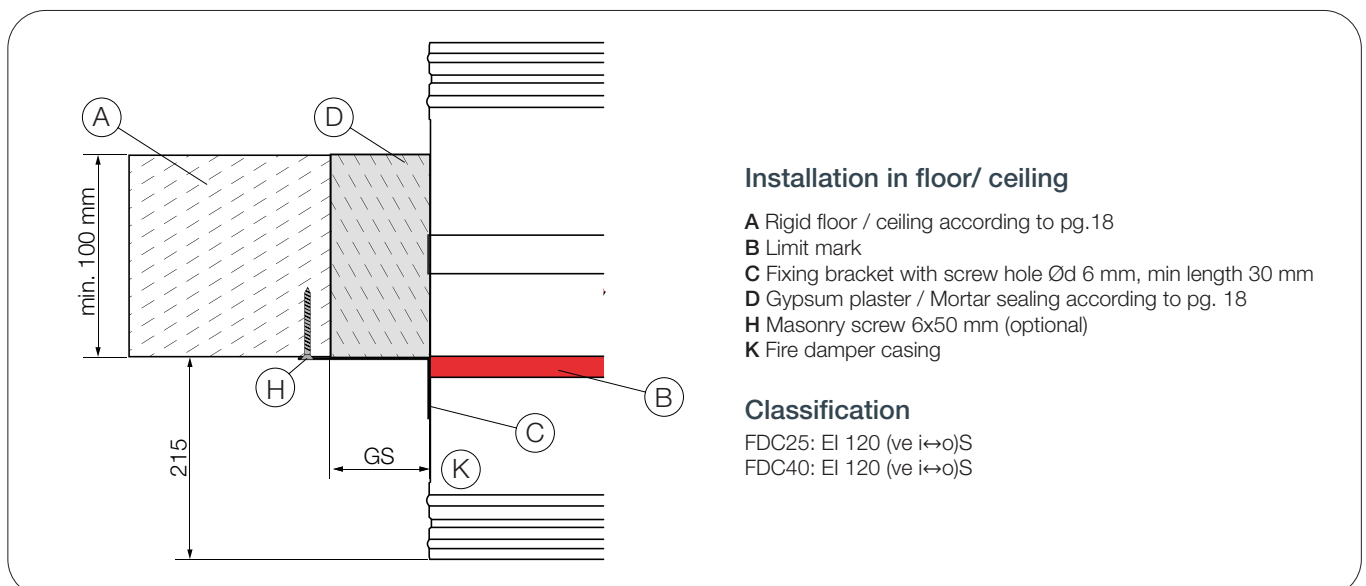



DOP



WALLS



MATERIALS

Possible damper orientations



0-360°

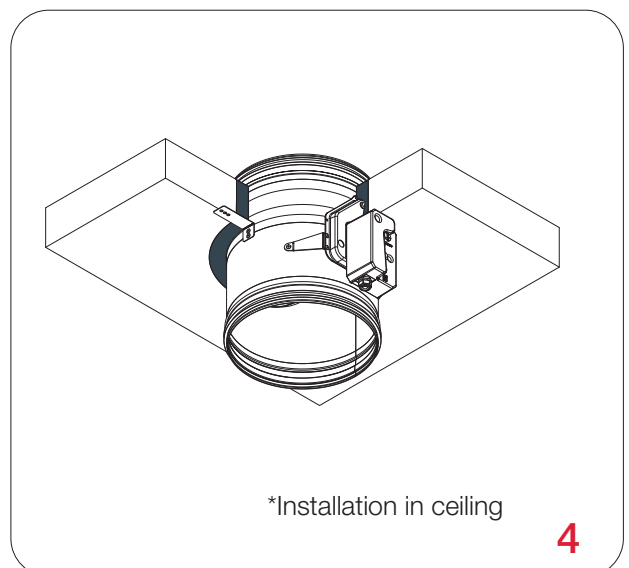
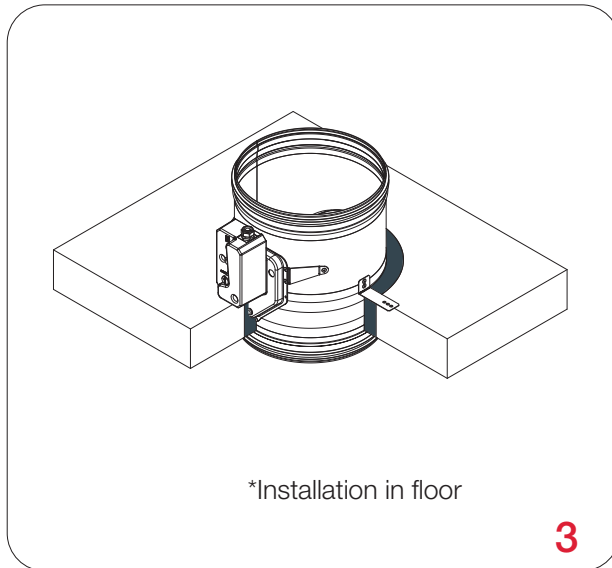
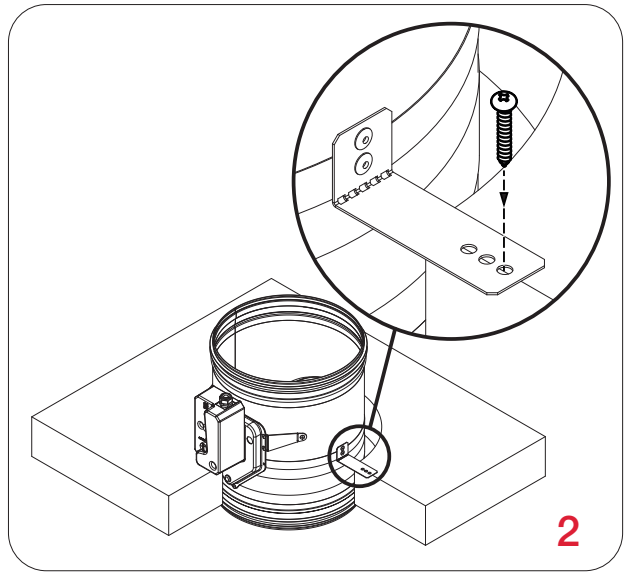
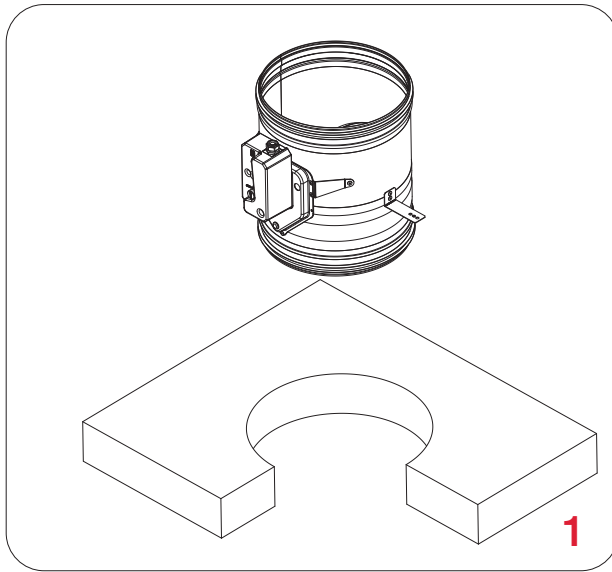

Damper blade must be closed during installation!

1. Create an opening in the floor/ceiling and bend the fixing bracket 90°. Place the damper in the opening up to the wall limit mark on the damper.

2. Fix the damper to the slab using screws (bracket screw hole is 6 mm in diameter).

3/3*. Fill the space between the damper and the slab with mortar or gypsum plaster.

Test the operation of the damper blade!

Damper size- Ød [mm]	Gap size - GS
100	55 mm
125	52,5 mm
160	47,5 mm
200	45 mm
250	42,5 mm
315	40 mm
355	40 mm
400	37,5 mm
450	37,5 mm
500	35 mm
560	35 mm
630	35 mm
710	32,5 mm
800	32,5 mm

* The images shown are for illustration purposes only and may not be an exact representation of the product.

Rigid floor installation (Fire Batt/ Weichschott)

Suspension systems are required for the Fire Batt/ Weichschott installation of the fire damper with mineral wool in floor slabs. Fire dampers can be suspended from solid floor slabs using adequately sized threaded rods. Load the suspension system only with the weight of the fire damper. Ducts must be suspended separately.

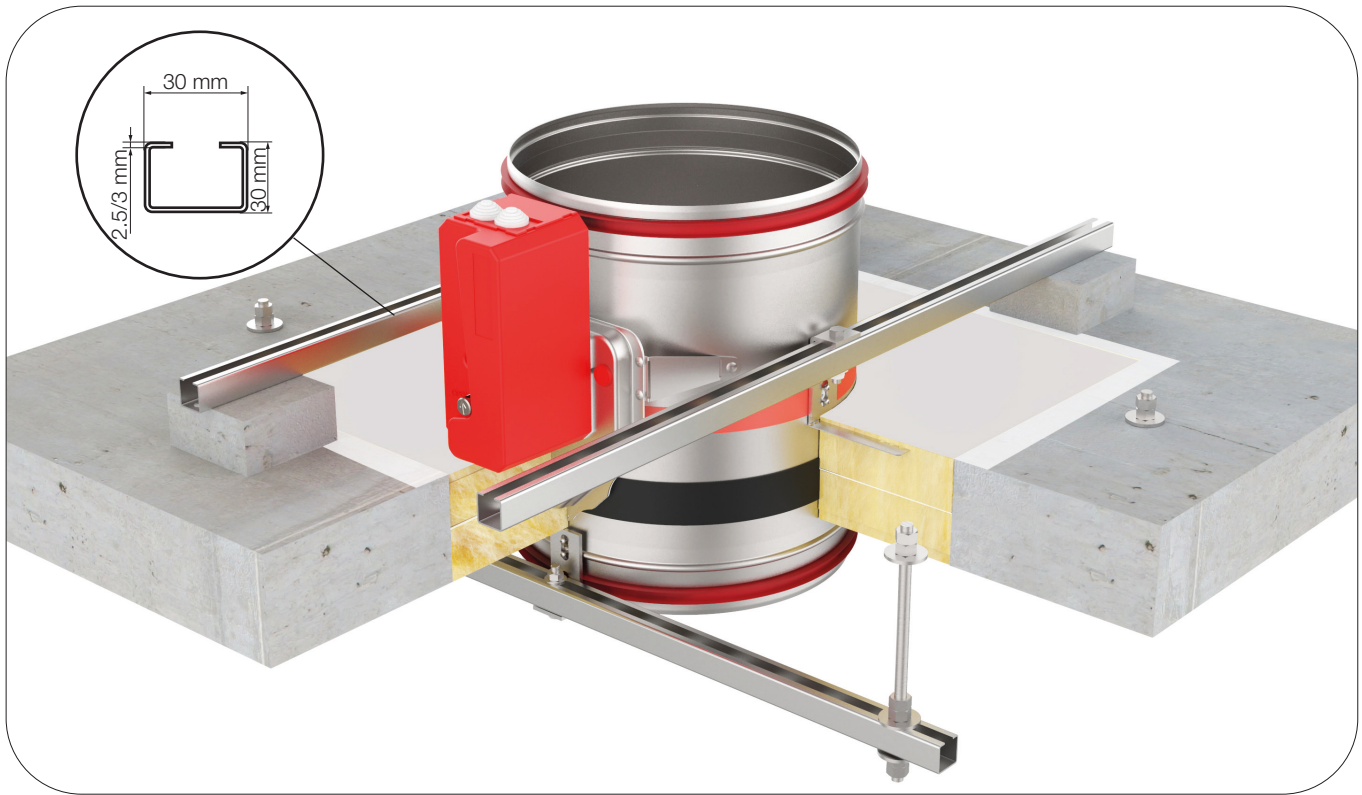

The ceiling is composed of concrete blocks (minimum density of 450 kg/m^3) or reinforced concrete (minimum density of 2200 kg/m^3) and with a minimum thickness of 100 mm.

Installation material: Mineral wool (minimum density of 140 kg/m^3), fire protection coating.

Suspension systems are required for the Fire Batt/Weichschott installation of the fire damper with mineral wool in floor and ceiling slabs.

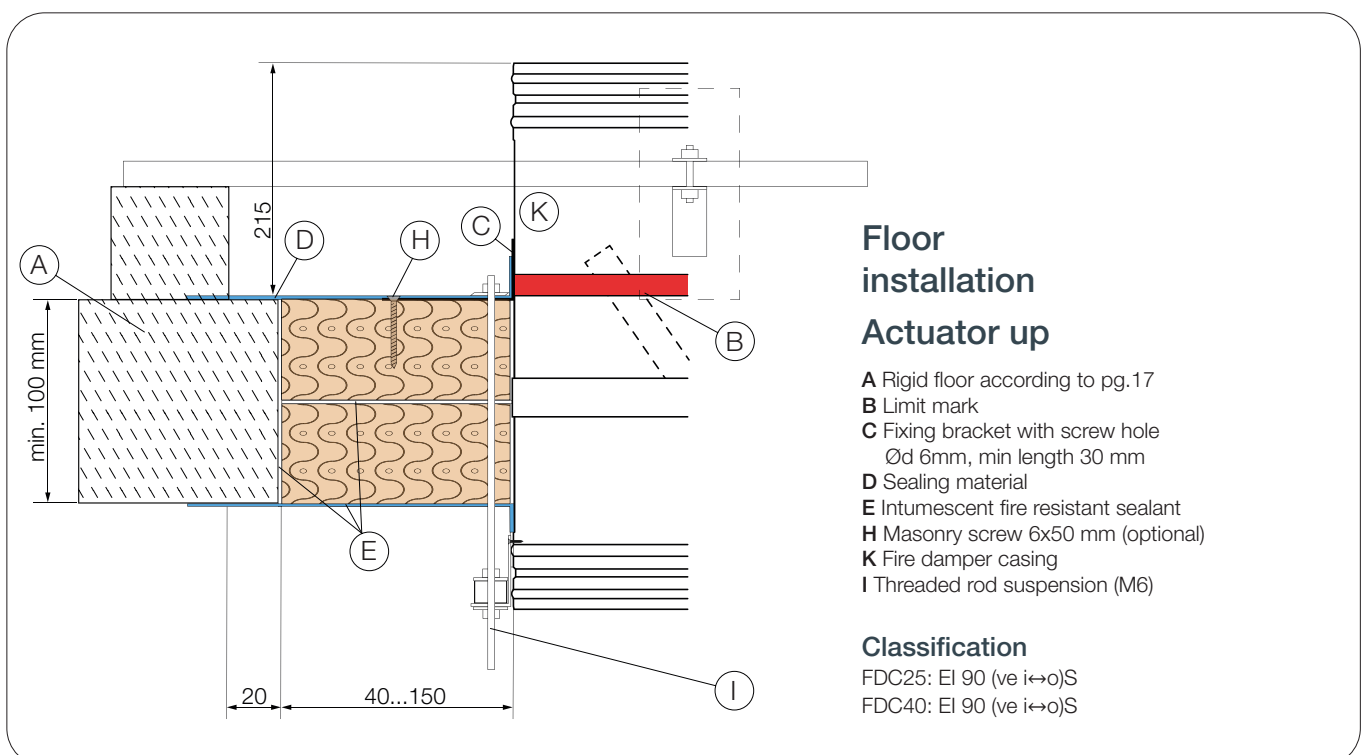



DOP



WALLS



MATERIALS

Possible damper orientations

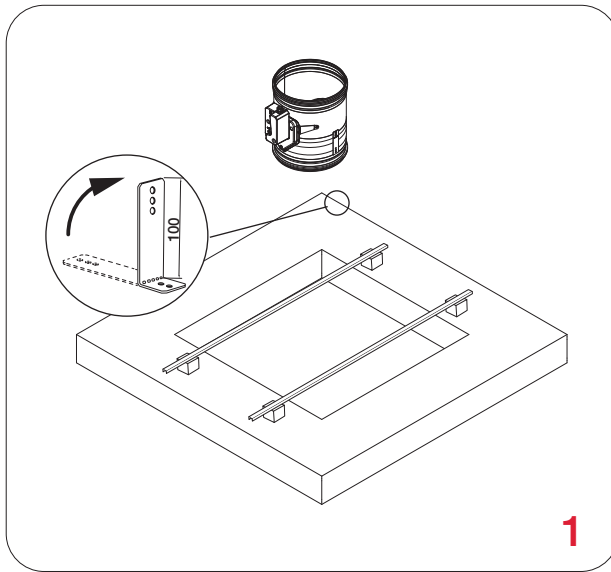

1

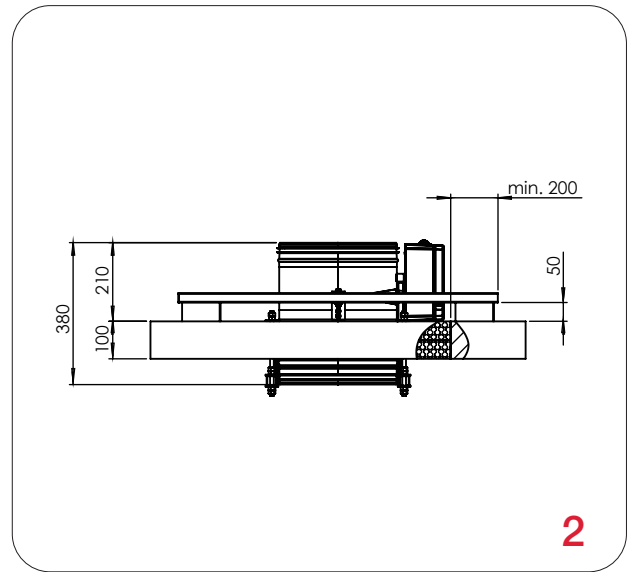

2

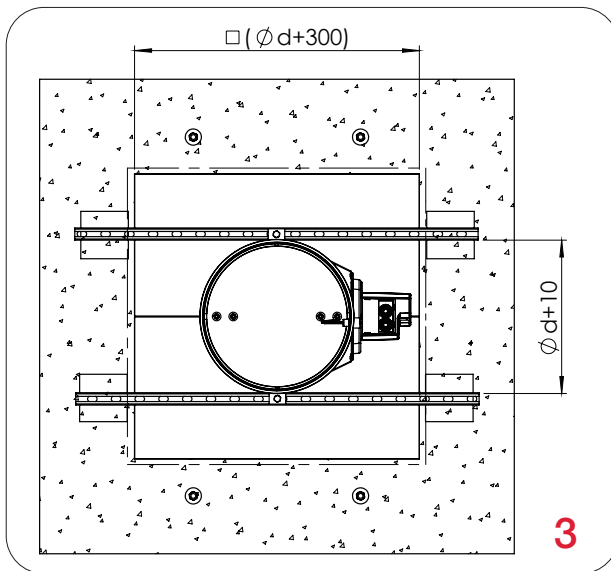

3

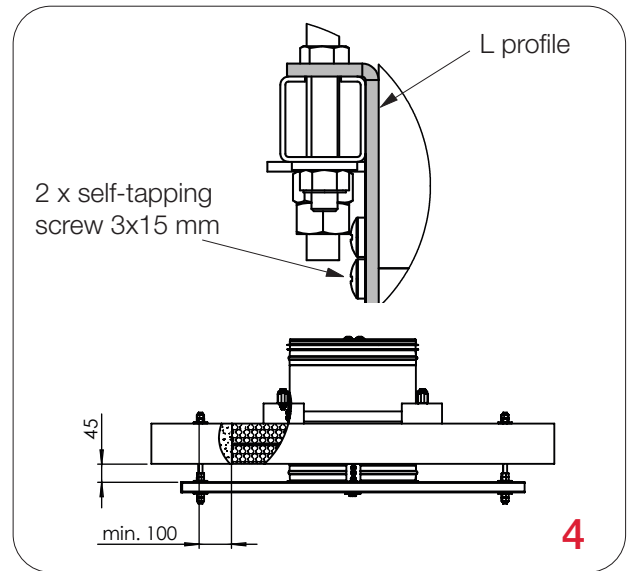

4

Damper blade must be closed during installation!

1. Create an opening in the floor ($B + 40 \dots 150$ mm) x ($H + 40 \dots 150$ mm). Bend the mounting bracket by 90° . Insert the damper into the opening up to the wall boundary mark on the damper.

For easier installation, the fire damper can be mounted on the floor / ceiling. Use approved / suitable screws for this purpose. (The mounting hole has a diameter of 6 mm.)

2. Suspension strut should be connected with drop rods (8/10 mm) to the floor slab above. It is used to support the damper and ease the installation.

3. When using L profile fixation, support steel C profile with 50 mm high piece of aerated concrete or similar rigid material. Not necessary if connecting rods directly to damper.

4. Damper casing is fixed to suspended and supported steel C profiles by two self tapping screws 4,8x16 (**make sure that it doesn't interfere with damper blade**) with L profile hanger (**detail A**) fixed to steel C profiles by M8 screw and nut. Position of self-tapping screws is trough the middle of damper casing.

For more details [see page 56-57](#).

Test the operation of the damper blade!

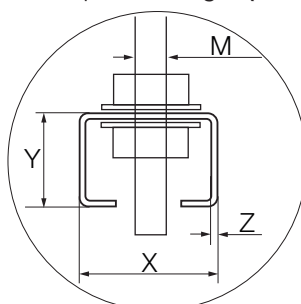

Suspension dimensions	X	Y	Z	M
FDC25	30	30	2.5	M8
FDC40	30	30	3	M10

Rigid ceiling installation (Fire Batt/ Weichschott)

Suspension systems are required for the Fire Batt/ Weichschott installation of the fire damper with mineral wool in ceiling slabs. Fire dampers can be suspended from solid ceiling slabs using adequately sized threaded rods. Load the suspension system only with the weight of the fire damper. Ducts must be suspended separately.

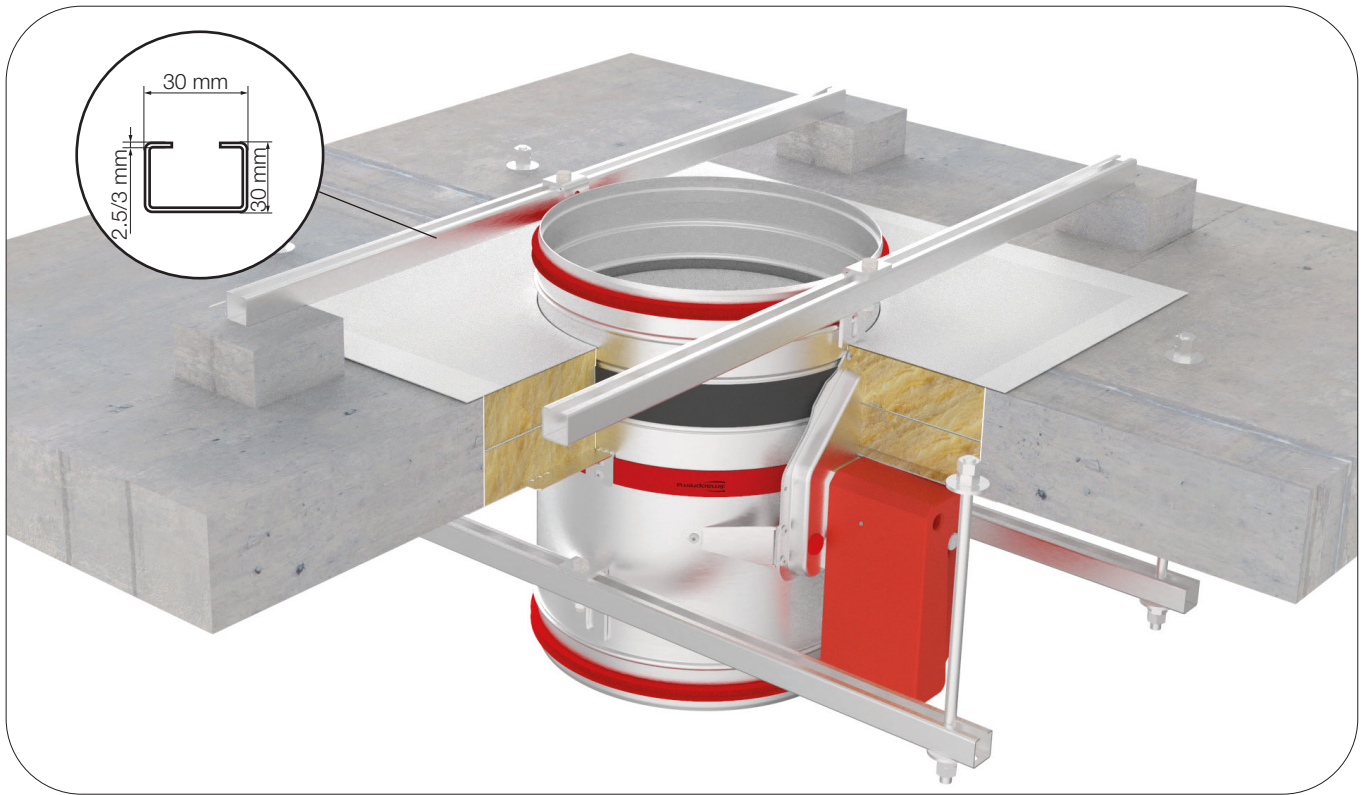

The ceiling is composed of concrete blocks (minimum density of 450 kg/m^3) or reinforced concrete (minimum density of 2200 kg/m^3) and with a minimum thickness of 100 mm.

Installation material: Mineral wool (minimum density of 140 kg/m^3), fire protection coating.

Suspension systems are required for the Fire Batt/Weichschott installation of the fire damper with mineral wool in floor and ceiling slabs.

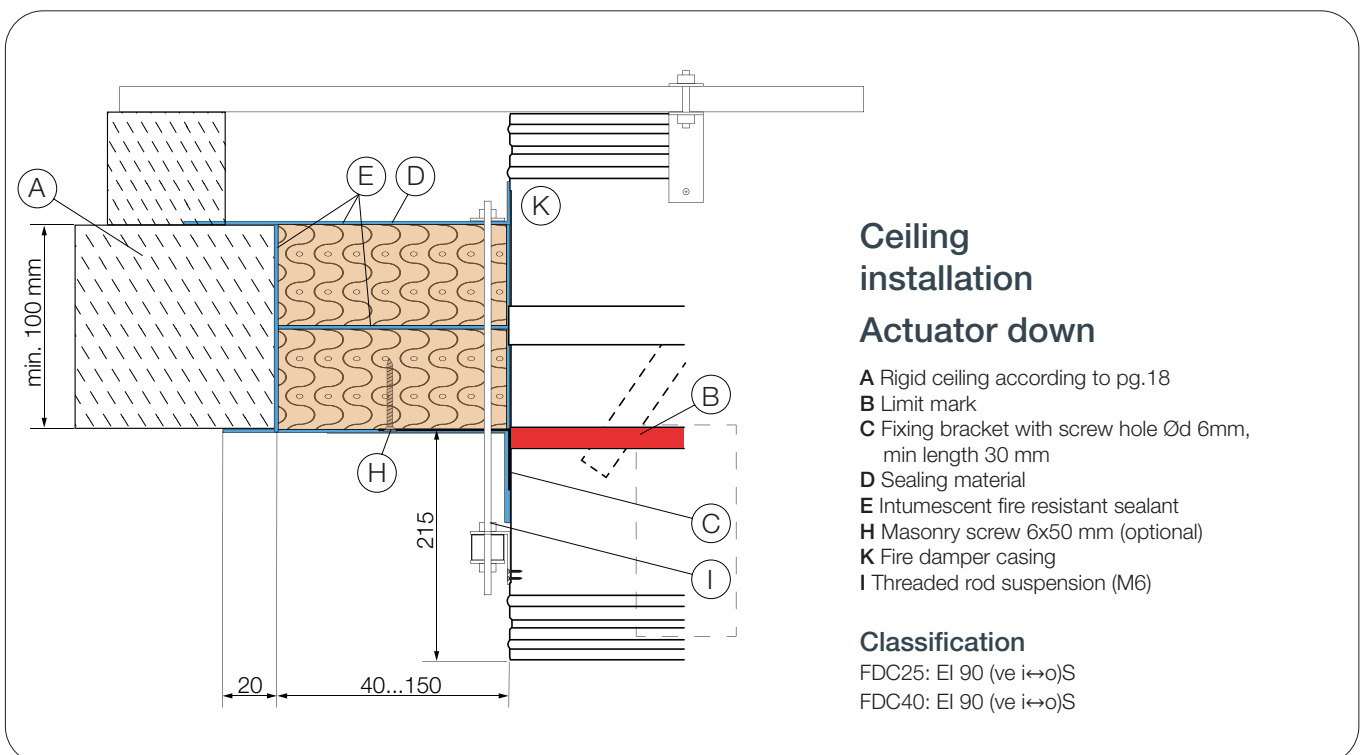



DOP



WALLS



MATERIALS

Possible damper orientations

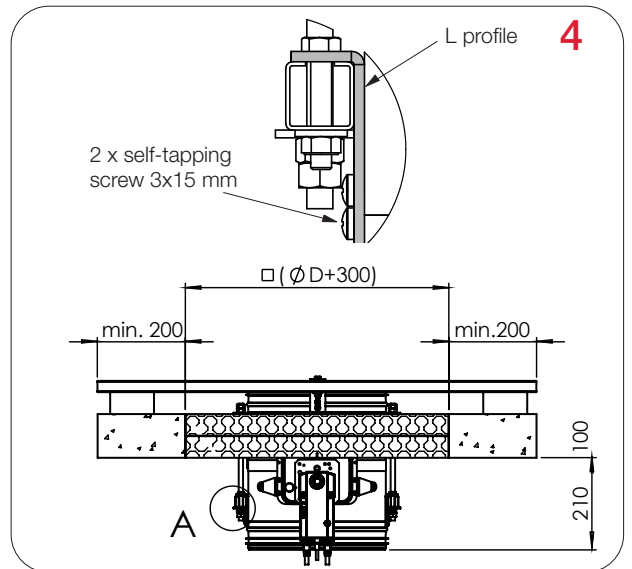
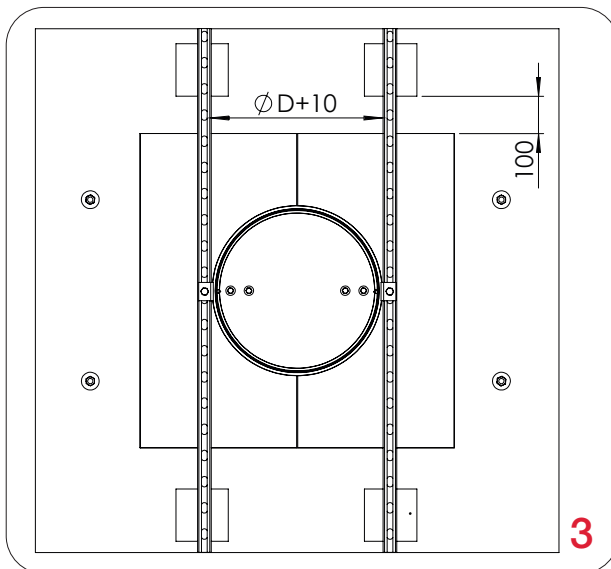
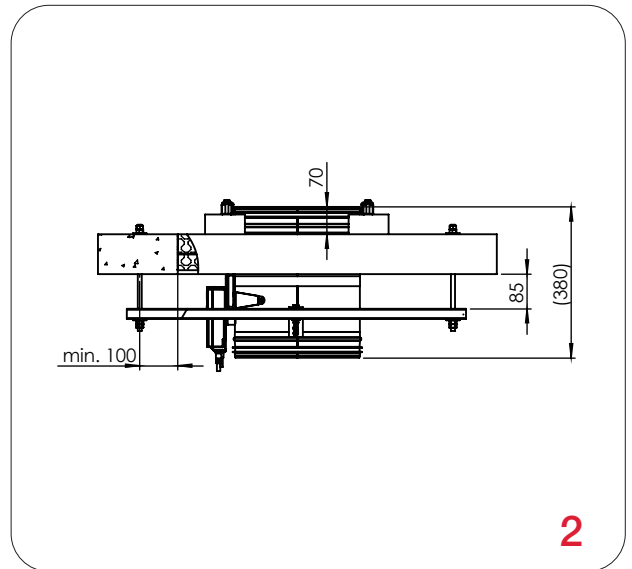
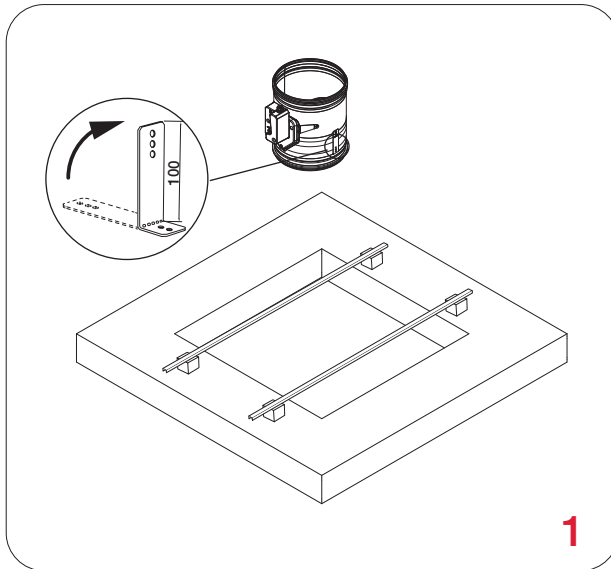

Damper blade must be closed during installation!

1. Create an opening in the ceiling (B + 40...150 mm) x (H + 40...150 mm). Bend the mounting bracket by 90°. Insert the damper into the opening up to the wall boundary mark on the damper.

For easier installation, the fire damper can be mounted on the floor / ceiling. Use approved / suitable screws for this purpose. (The mounting hole has a diameter of 6 mm.)

2. Suspension strut should be connected with drop rods (8/10 mm) to the floor slab above. It is used to support the damper and ease the installation.

3. When using L profile fixation, support steel C profile with 50 mm high piece of aerated concrete or similar rigid material. Not necessary if connecting rods directly to damper.

4. Damper casing is fixed to suspended and supported steel C profiles by two self tapping screws 4,8x16 (make sure that it doesn't interfere with damper blade) with L profile hanger (detail A) fixed to steel C profiles by M8 screw and nut. Position of self-tapping screws is trough the middle of damper casing.

For more details [see page 56-57](#).

Test the operation of the damper blade!

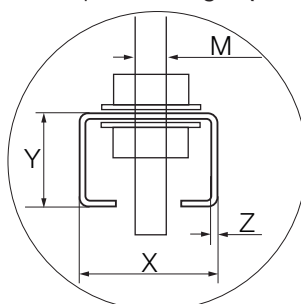

Suspension dimensions	X	Y	Z	M
FDC25	30	30	2.5	M8
FDC40	30	30	3	M10

* The images shown are for illustration purposes only and may not be an exact representation of the product.

Rigid floor/ceiling installation (Fire Batt/ Weichschott)

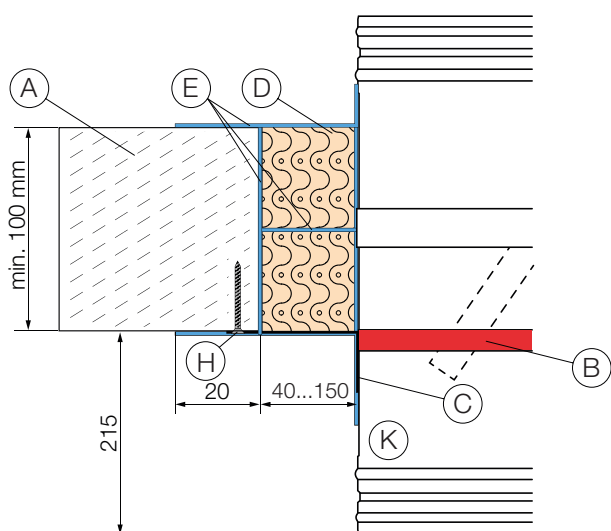
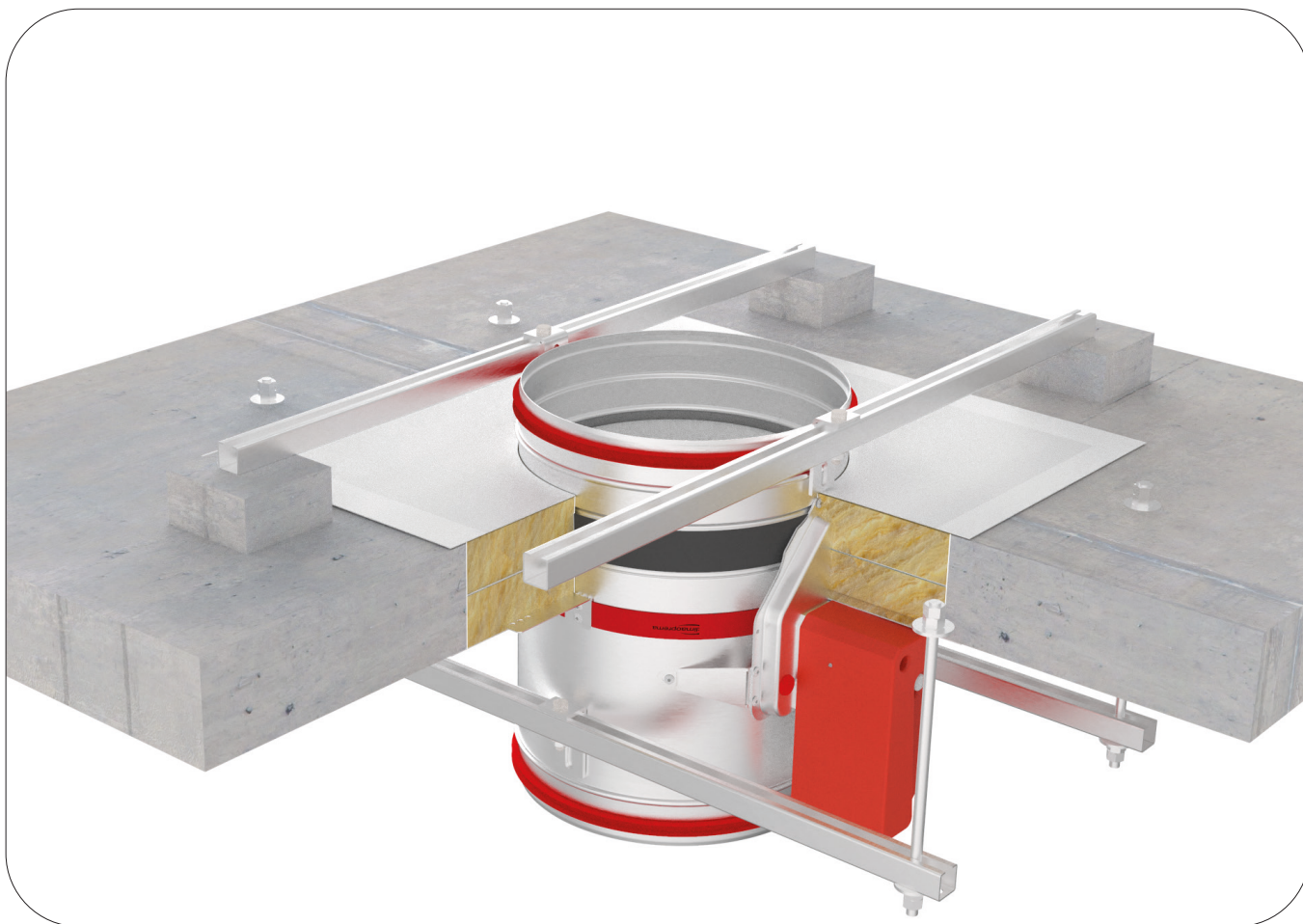

Installation in floor/ ceiling

- A Rigid ceiling according to pg.18
- B Limit mark
- C Fixing bracket with screw hole \varnothing d 6 mm, min length 30 mm
- D Gypsum plaster / Mortar sealing according to pg. 18
- H Masonry screw 6x50 mm (optional)
- K Fire damper casing

Classification

- FDC25: EI 90 (ve i↔o)S
- FDC40: EI 90 (ve i↔o)S



DOP



WALLS



MATERIALS

Possible damper orientations



0-90° -
180°-270°

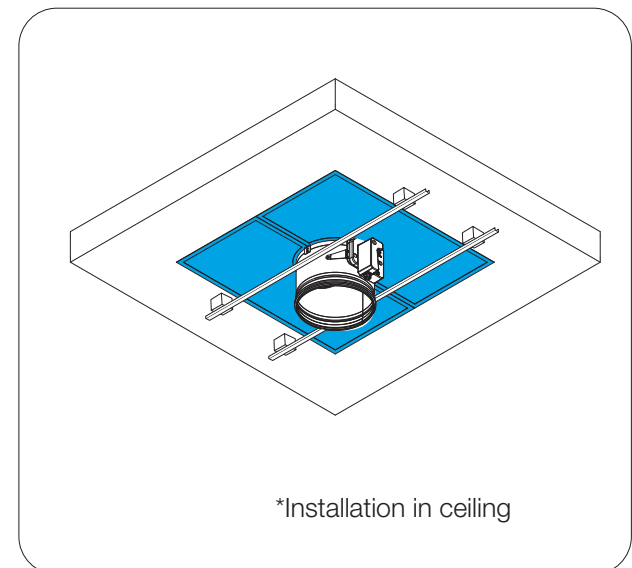
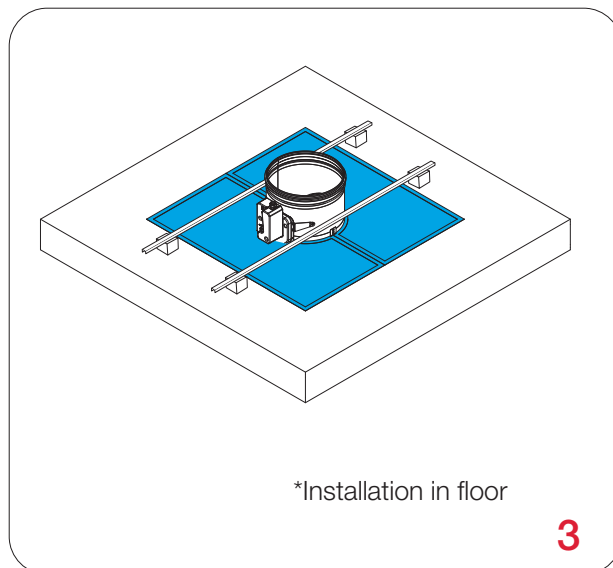
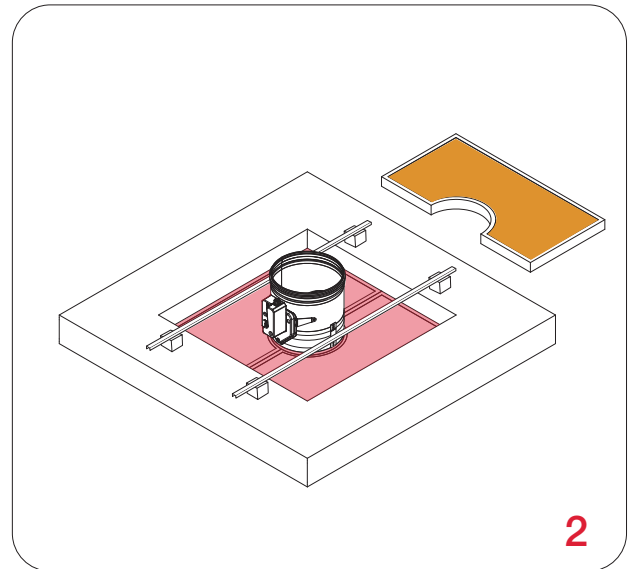
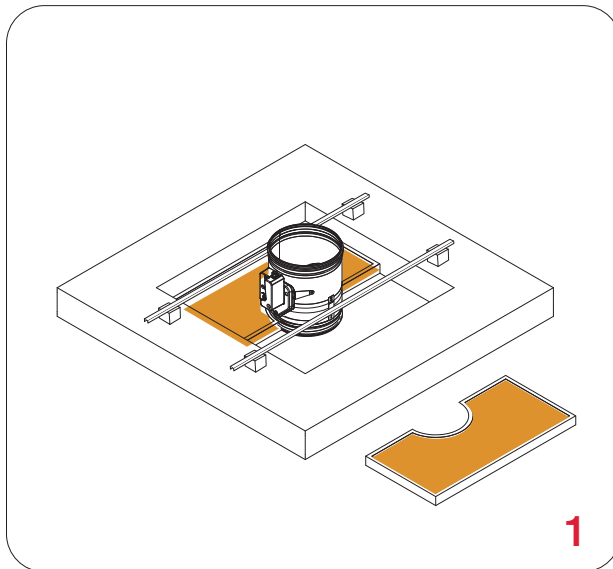

Damper blade must be closed during installation!

1. Close the gap between the housing and the wall with the first layer of mineral wool (50 mm thick, coated on the inside). Seal the joints between the pieces of mineral wool with intumescent, fire-resistant sealant.

2. Close the gap between the housing and the wall with the second layer of mineral wool (50 mm thick, coated on the inside). The joints between the mineral wool pieces must be sealed with intumescent, fire-resistant sealant.

3. The outside of the mineral wool and the damper housing must be coated with a 2 mm thick fire protection coating. The damper housing should be coated up to the profile projections.

*Fire Batt floor/ceiling installations require a suspension for the fire damper.
For more details; see [page 52 for floor](#) , see [page 54 for ceiling](#).

Test the operation of the damper blade!

Rigid wall installation

Applique installation frame



The wall is composed of concrete blocks (minimum density of 450 kg/m³) or reinforced concrete (minimum density of 2200 kg/m³) and with a minimum thickness of 100 mm.

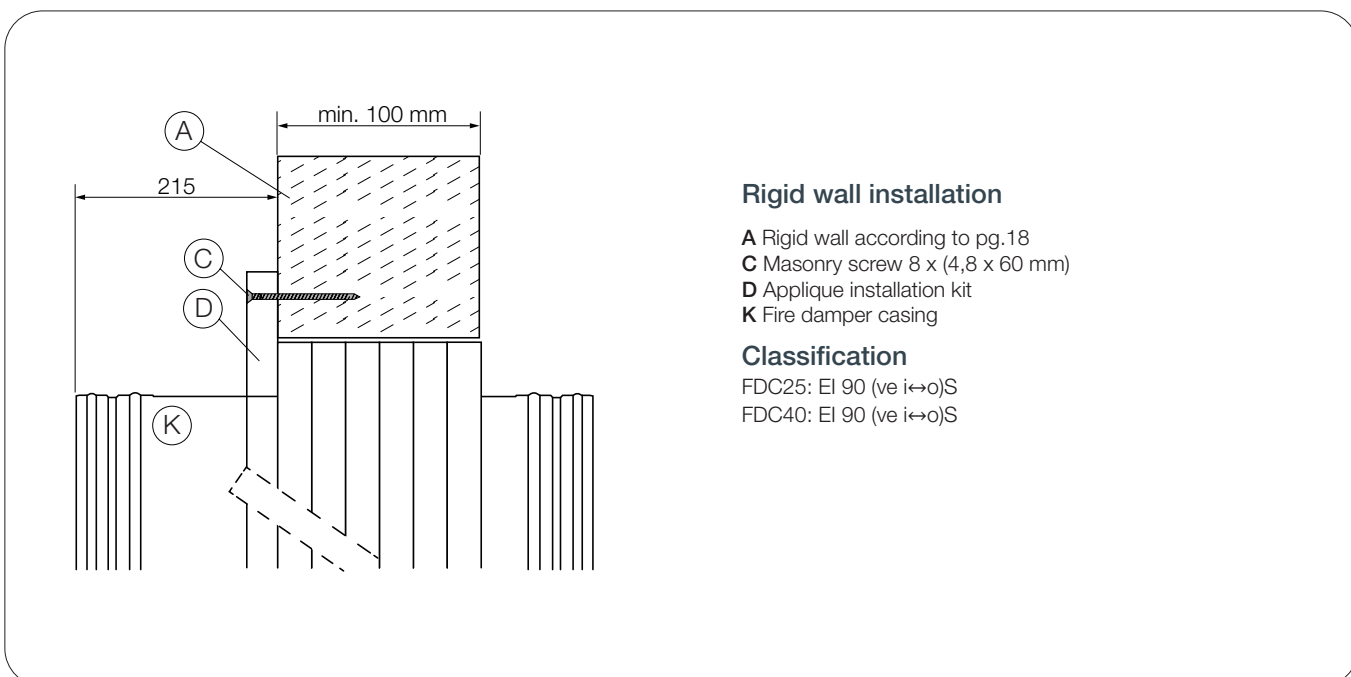

Rigid wall installation

- A Rigid wall according to pg.18
- C Masonry screw 8 x (4,8 x 60 mm)
- D Applique installation kit
- K Fire damper casing

Classification

- FDC25: EI 90 (ve i↔o)S
- FDC40: EI 90 (ve i↔o)S



DOP



WALLS



MATERIALS

Possible damper orientations



0-90° -
180°-270°

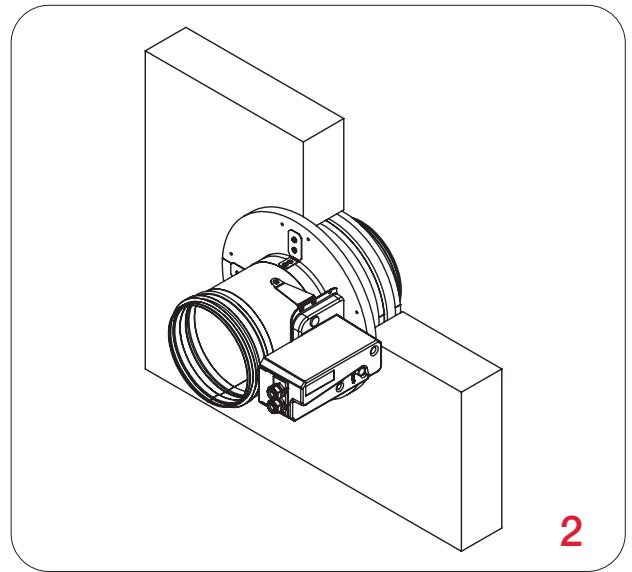
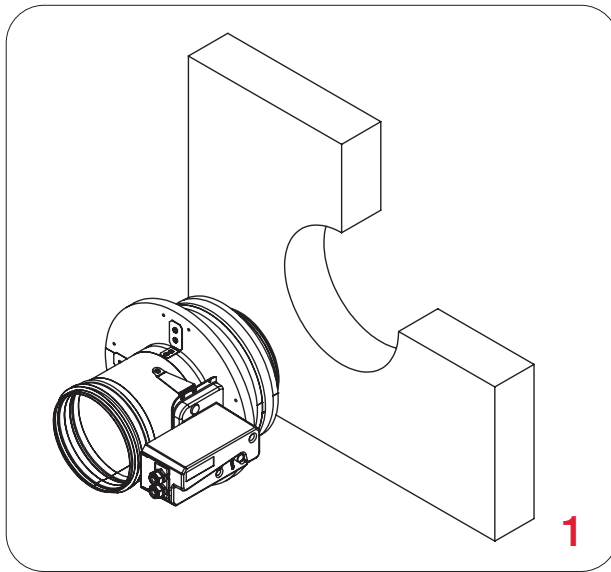

Wall opening dimensions

Damper diameter Ød [mm]	Wall opening [mm]
100	Ød + 105...115 mm
125-180	Ød + 95...105 mm
200-315	Ød + 80...90 mm

Damper blade must be closed during installation!

1. Create a wall opening according to the dimensions in the table below.
2. Insert fire damper into wall and fasten with screws (8 pcs, 4,8x60 mm).

Test the operation of the damper blade!

* The images shown are for illustration purposes only and may not be an exact representation of the product.

Gypsum blocks wall installation

Applique installation frame



The wall is composed of gypsum blocks (minimum density of 995 kg/m^3), and with minimum thickness of 70 mm.

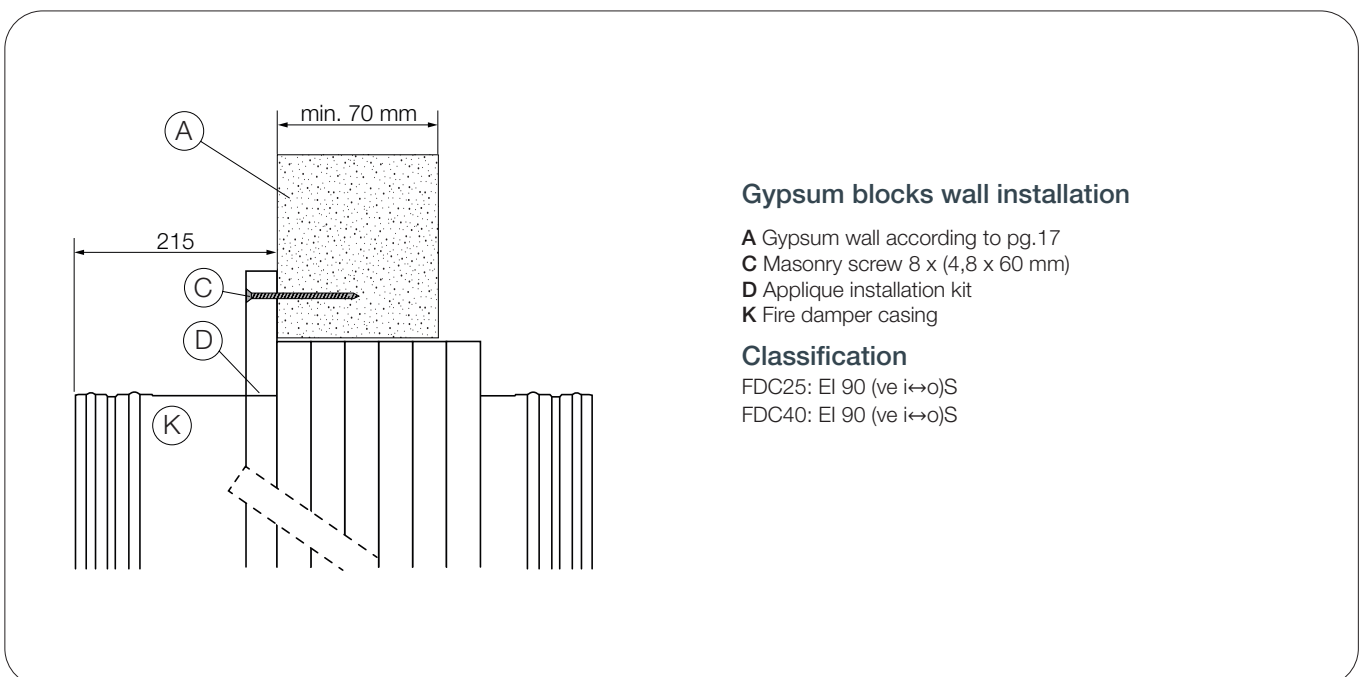



DOP



WALLS



MATERIALS

Possible damper orientations



0-90° -
180°-270°

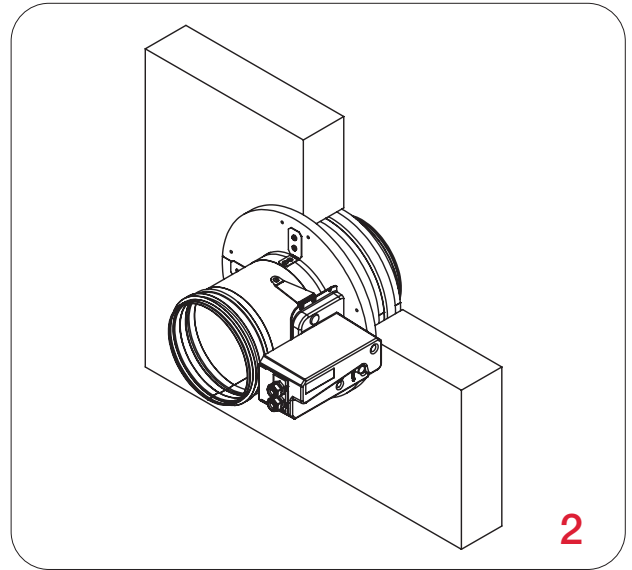
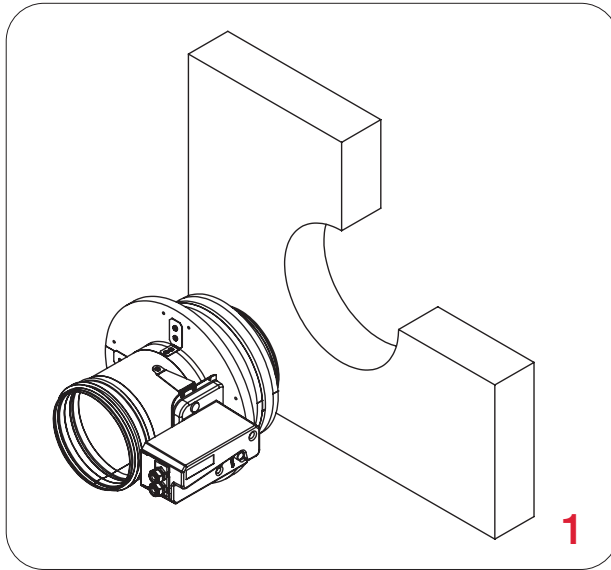

Wall opening dimensions

Damper diameter Ød [mm]	Wall opening [mm]
100	Ød + 105...115 mm
125-180	Ød + 95...105 mm
200-315	Ød + 80...90 mm

Damper blade must be closed during installation!

1. Create a wall opening according to the dimensions in the table below.
2. Insert fire damper into wall and fasten with screws (8 pcs, 4,8x60 mm).

Test the operation of the damper blade!

* The images shown are for illustration purposes only and may not be an exact representation of the product.

Flexible wall installation

Applique installation frame

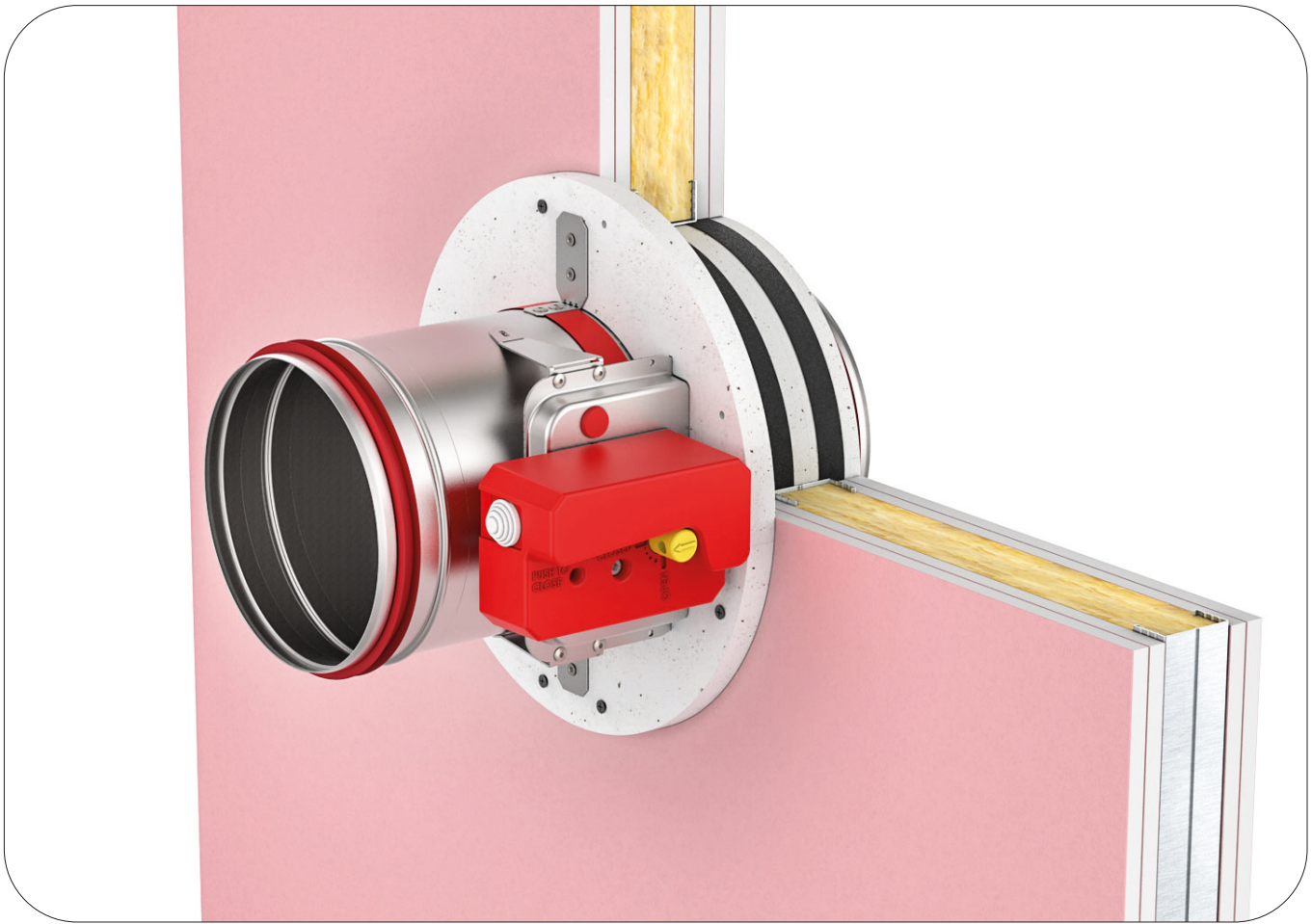

The wall is composed of 2x2 plasterboard boards, 12,5 mm thick, installed on a steel frame construction. To fulfill the classification it is **NOT** mandatory to use the mineral wool inside the wall (mineral wool with density up to 100 kg/m³ can be used). The minimum thickness of the wall is 100 mm.

EI 90 (ve i↔o)S The wall is made out of type F (EN520) gypsum plaster boards.

EI 60 (ve i↔o)S The wall is made out of type A (EN520) gypsum plaster boards.

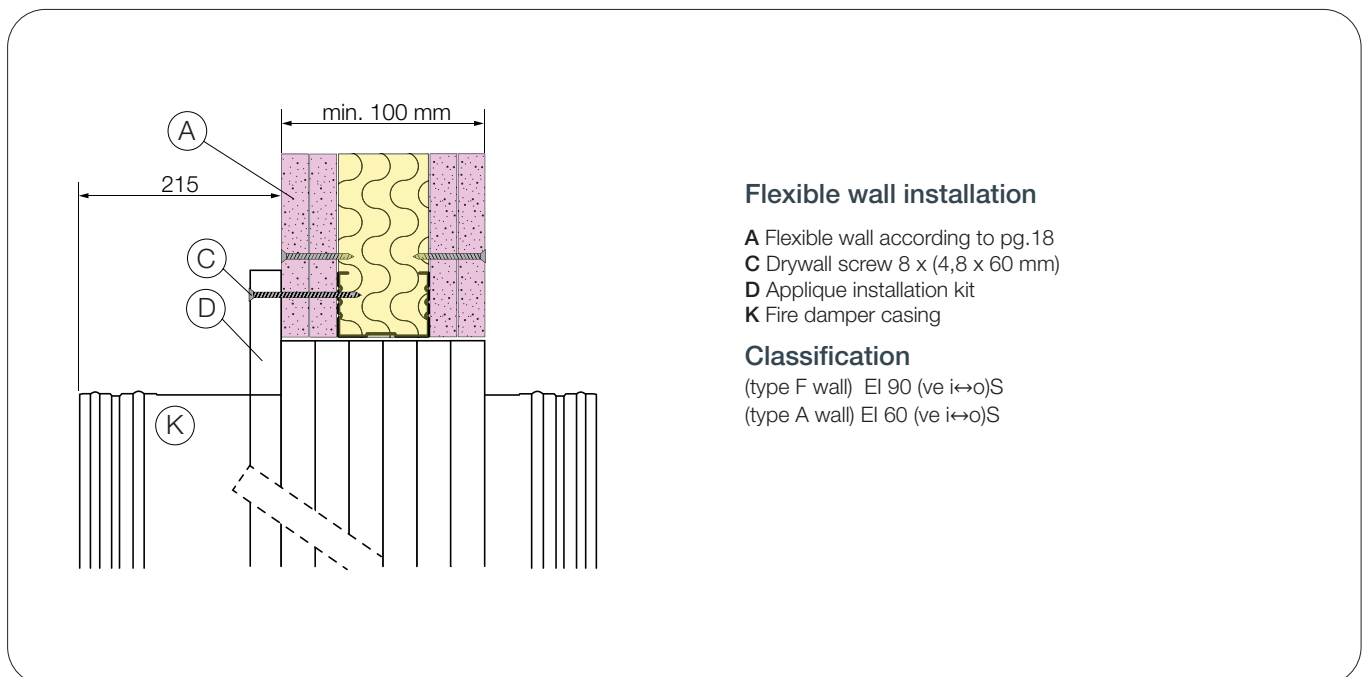



DOP



WALLS



MATERIALS

Possible damper orientations

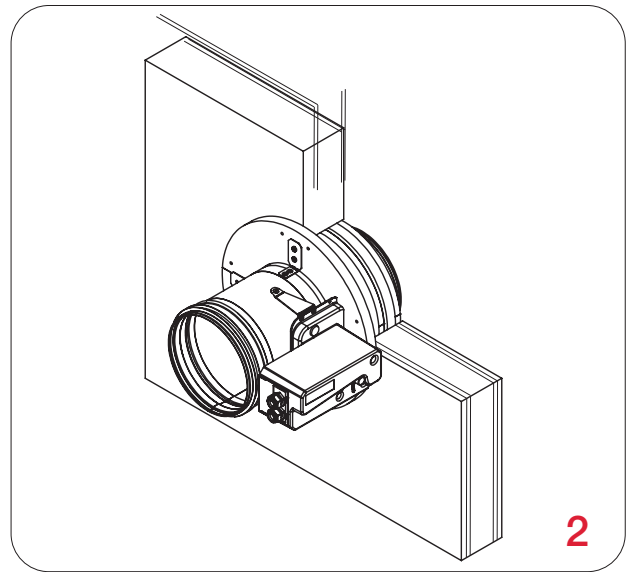
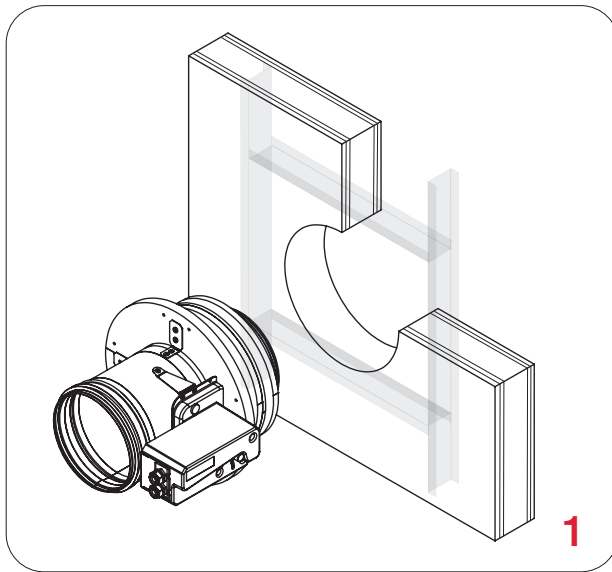

Wall opening dimensions

Damper diameter Ød [mm]	Wall opening [mm]
100	Ød + 105...115 mm
125-180	Ød + 95...105 mm
200-315	Ød + 80...90 mm

Damper blade must be closed during installation!

*Create an opening according to the table below and build the subframe according to the drawing, [see page 16](#).

1. Place the fire damper in the opening.
2. Fasten the fire damper with screws (8 pcs, 4,8x60 mm).

Test the operation of the damper blade!

* The images shown are for illustration purposes only and may not be an exact representation of the product.

Rigid wall installation

MF1/MF2 installation frame

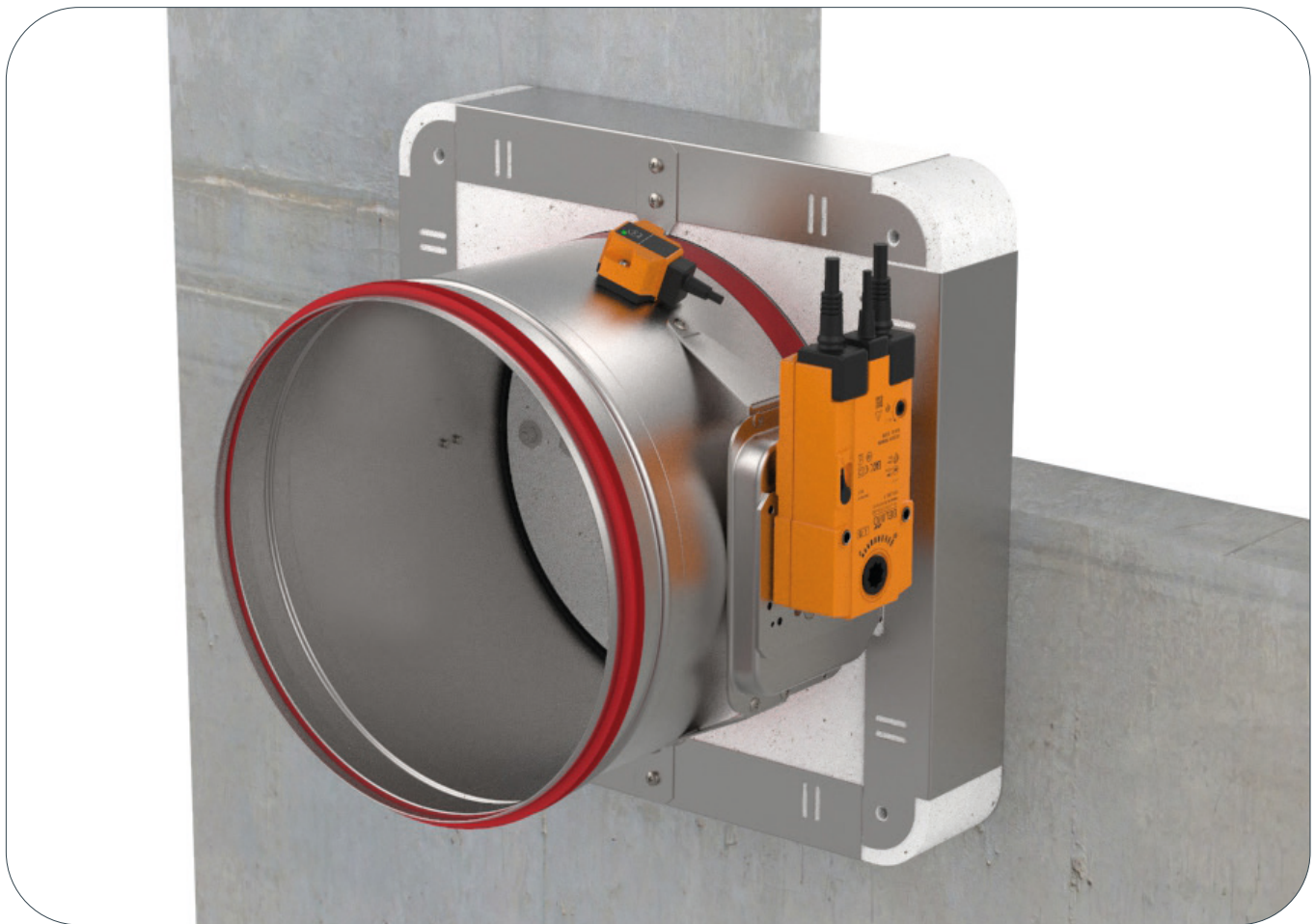

The wall is composed of concrete blocks (minimum density of 450 kg/m^3) or reinforced concrete (minimum density of 2200 kg/m^3) and with a minimum thickness of 100 mm.

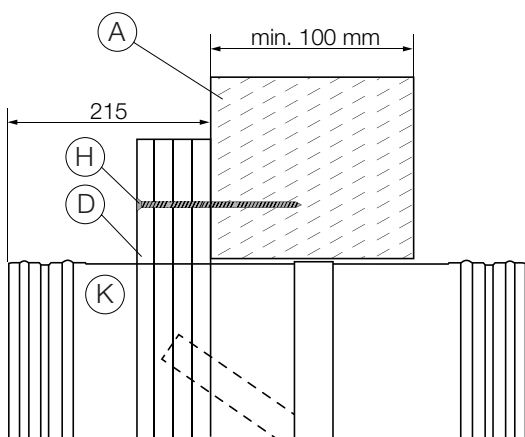

Rigid wall installation

A Rigid wall according to pg.18

D MF installation kit

H Masonry screw, (MF1 FDC25 4 pcs. 6x120mm, MF2 FDC25 12 pcs. 6x160mm, MF2 FDC40 12 pcs. 6x160mm)

K Fire damper casing

Classification

FDC25 MF1: EI 60 (ve i↔o)S

FDC40 MF2: EI 90 (ve i↔o)S



DOP



WALLS



MATERIALS

Possible damper orientations

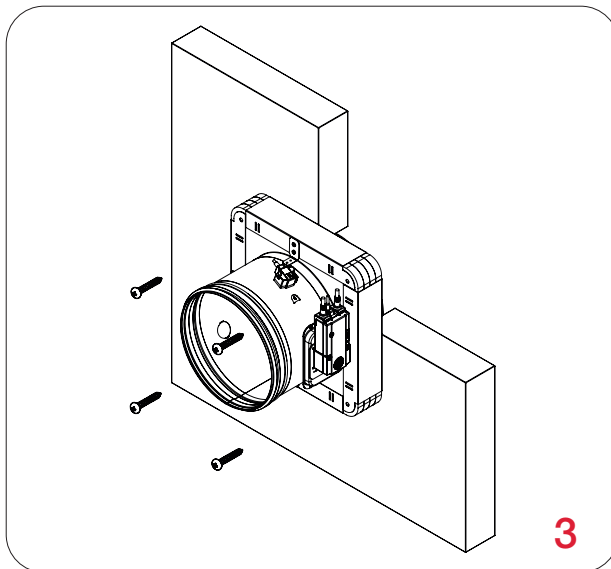
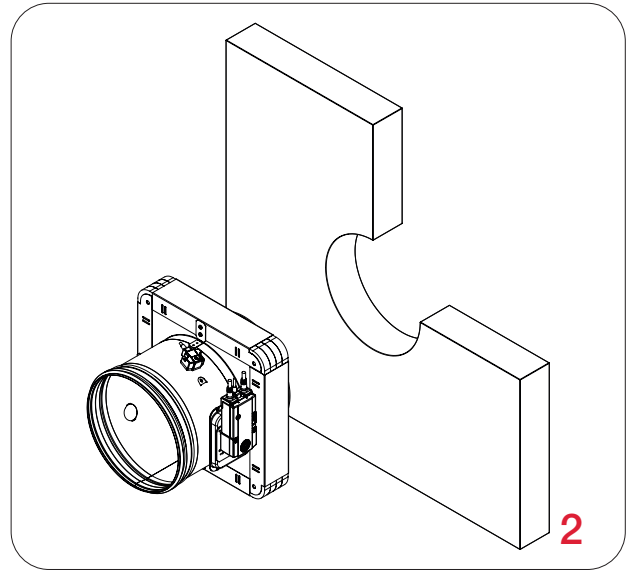
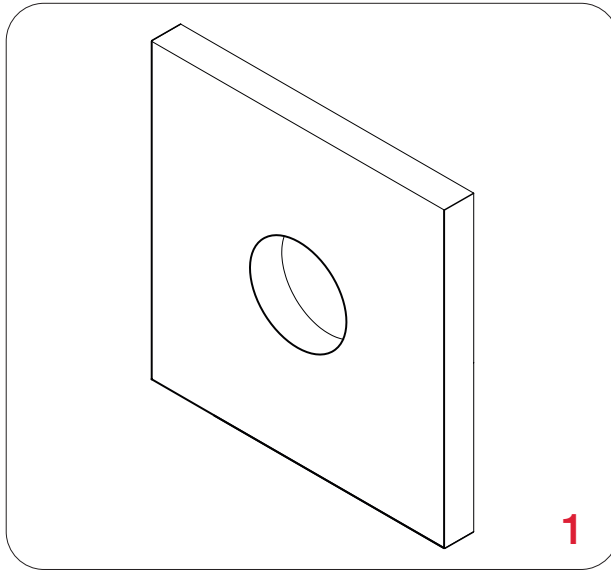

Damper blade must be closed during installation!

1. Create an opening in the wall (FDC25- Ød +10 mm, FDC40-Ød + 25 mm).
2. Place the damper in the opening.
3. Fasten the fire damper with screws
 - MF1 - 4 pcs, 6x140 mm,
 - MF2 - 12 pcs, 6x140 mm

Test the operation of the damper blade!

Gypsum blocks wall MF1/MF2 installation frame

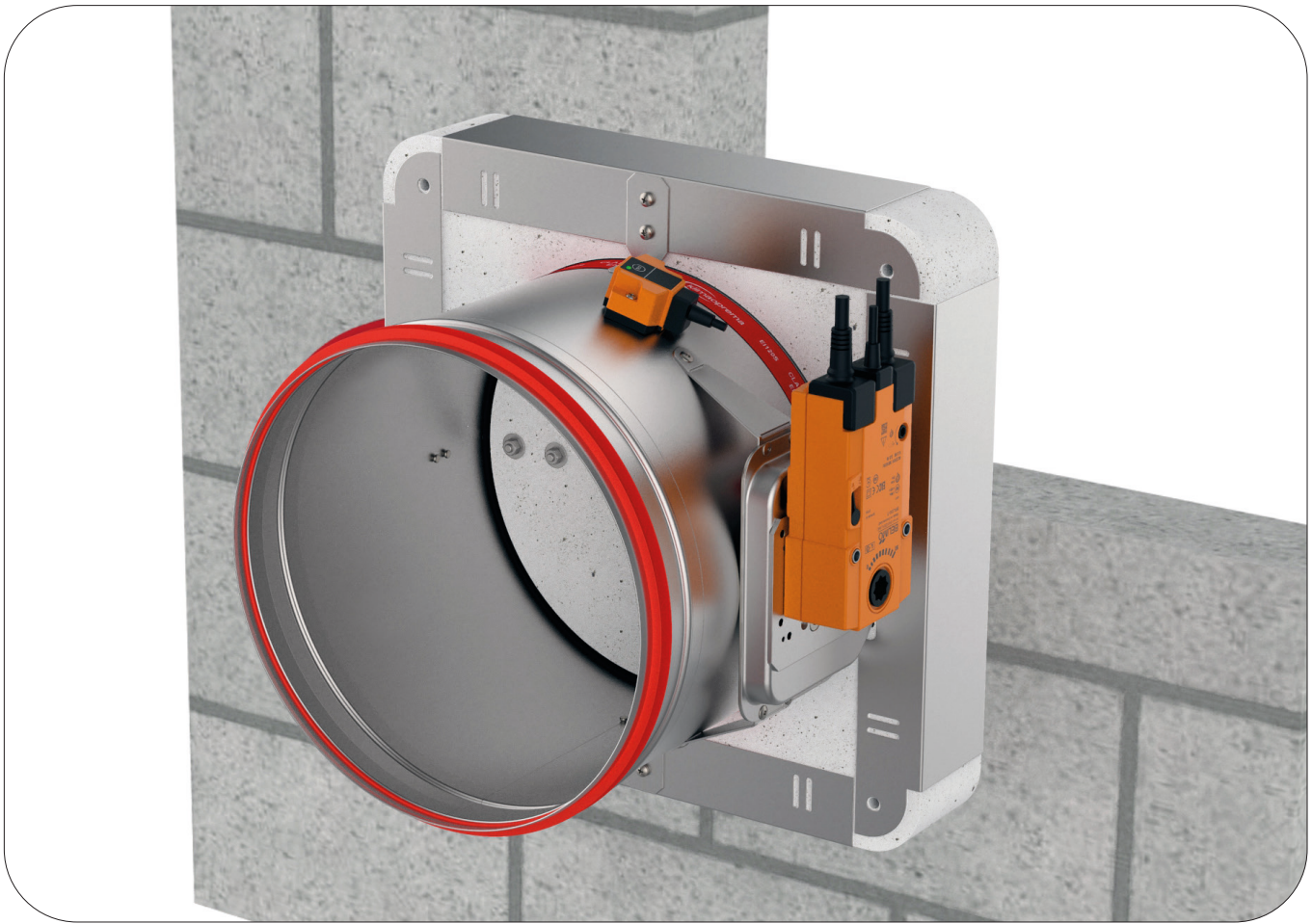

The wall is composed of gypsum blocks (minimum density of 995 kg/m³) and with minimum thickness of 70 mm.

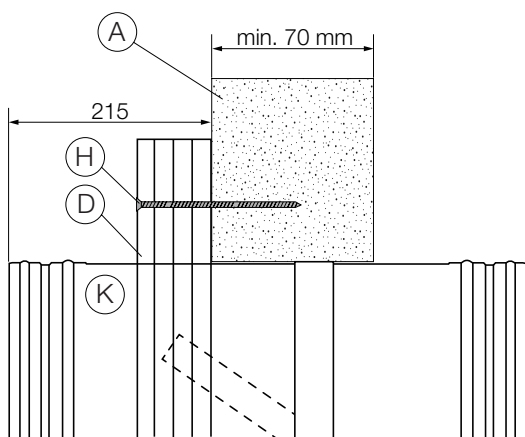

Gypsum blocks wall installation

A Gypsum wall according to pg.18

D MF installation kit

H Masonry screw (MF1 FDC25 4 pcs. 6x120mm, MF2 FDC25 12 pcs. 6x160mm, MF2 FDC40 12 pcs. 6x160mm)

K Fire damper casing

Classification

FDC25 MF1: EI 60 (ve i↔o)S

FDC40 MF2: EI 90 (ve i↔o)S



DOP



WALLS



MATERIALS

Possible
damper
orientations

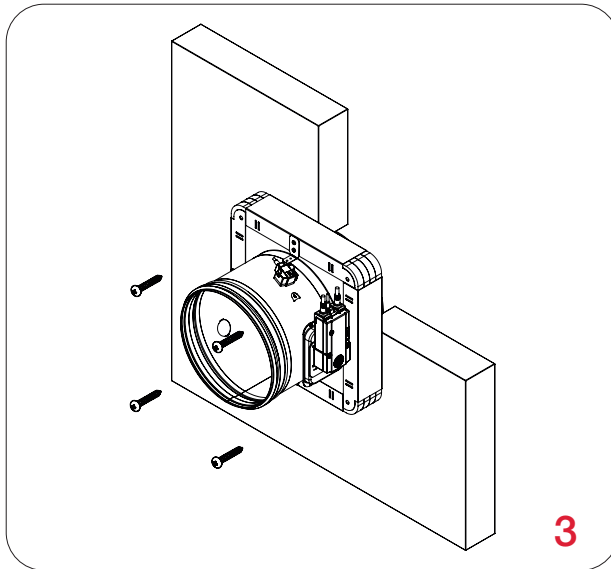
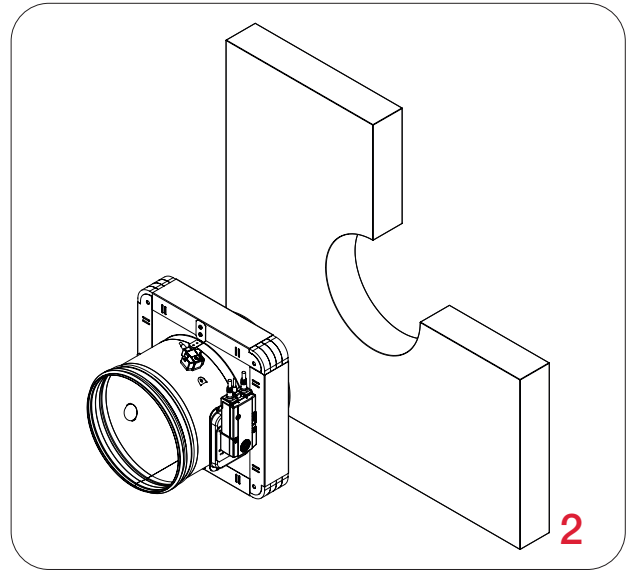
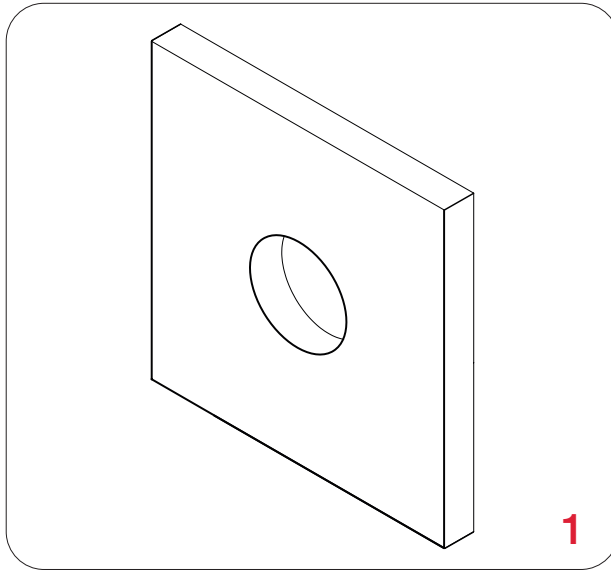

Damper blade must be closed during installation!

1. Create an opening in the wall (FDC25- $\text{Ød} + 10$ mm, FDC40- $\text{Ød} + 25$ mm).
2. Place the damper in the opening.
3. Fasten the fire damper with screws
MF1 - 4 pcs, 6x140 mm,
MF2 - 12 pcs, 6x140 mm

Test the operation of the damper blade!

Flexible wall installation

MF1/MF2 installation frame



MF1 (EI 60 (ve i↔o)S)

The wall is made out of type A (EN520) gypsum plaster boards. To fulfill the classification it is **NOT** mandatory to use the mineral wool inside the wall (mineral wool with density up to 60 kg/m³ can be used). The minimum thickness of the wall is 100 mm.

MF2 (EI 90 (ve i↔o)S)

The wall is made out of type F (EN520) gypsum plaster boards, installed on a steel frame construction. To fulfill the classification it is **NOT** mandatory to use the mineral wool inside the wall (mineral wool with density up to 100 kg/m³ can be used). The minimum thickness of the wall is 100 mm.

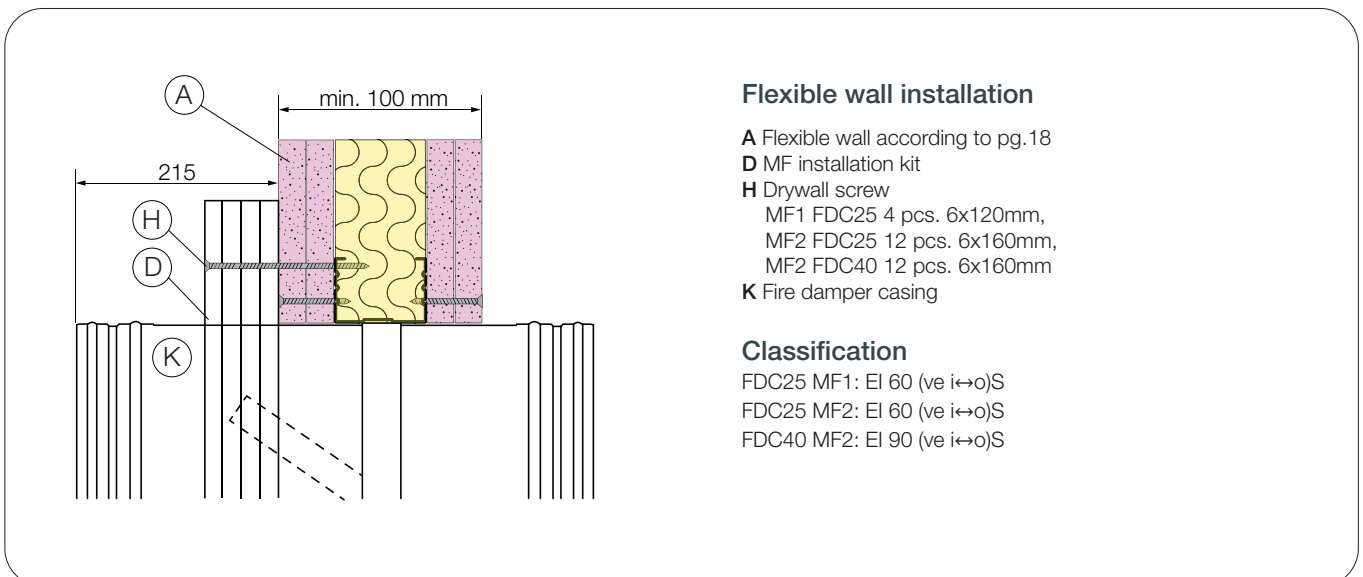



DOP



WALLS



MATERIALS

Possible damper orientations

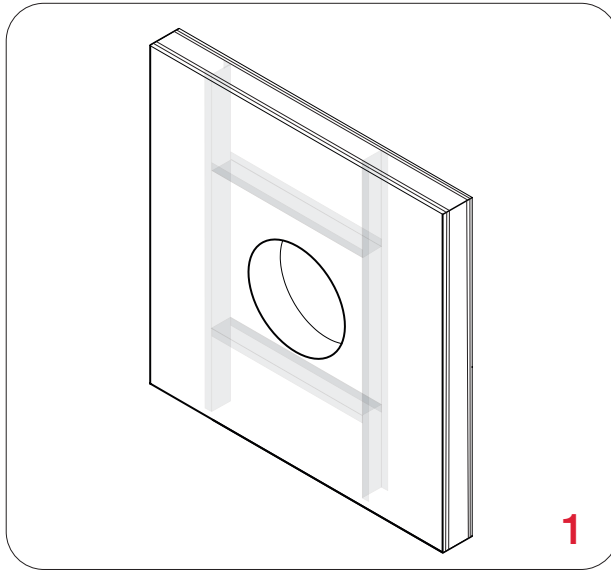

1

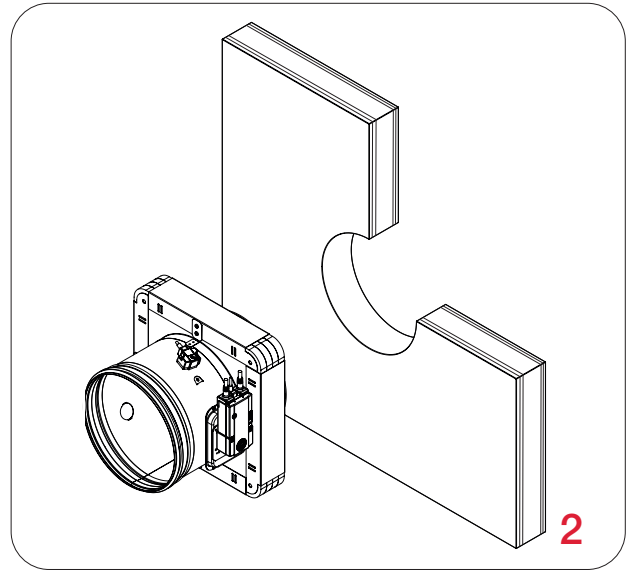

2

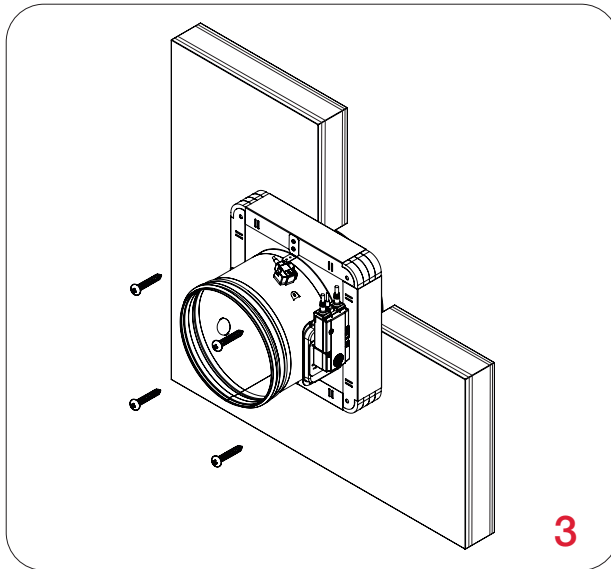

3

Damper blade must be closed during installation!

1. Create an opening in the wall (FDC25- $\text{Ød} + 10 \text{ mm}$, FDC40- $\text{Ød} + 25 \text{ mm}$) and build the subframe according to the drawing, [see page 16](#).

2. Place the fire damper in the opening.

3. Fasten the fire damper with screws

MF1 - 4 pcs, 6x140 mm,
MF2 - 12 pcs, 6x140 mm

Test the operation of the damper blade!

Rigid floor/ceiling installation

MF2 installation frame

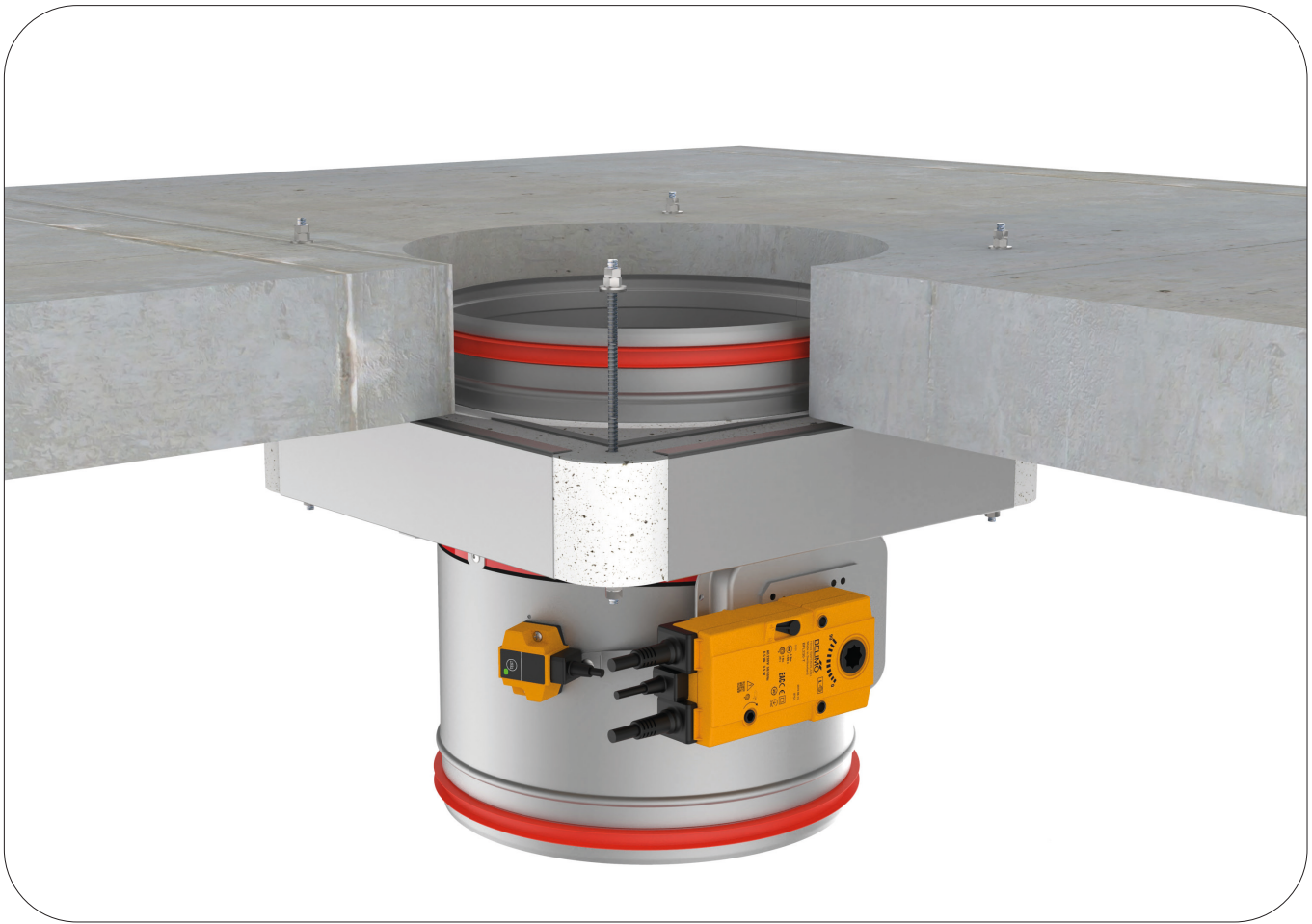

The floor/ceiling is composed of concrete blocks (minimum density of 450 kg/m³) or reinforced concrete (minimum density of 2200 kg/m³) and with a minimum thickness of 100 mm.

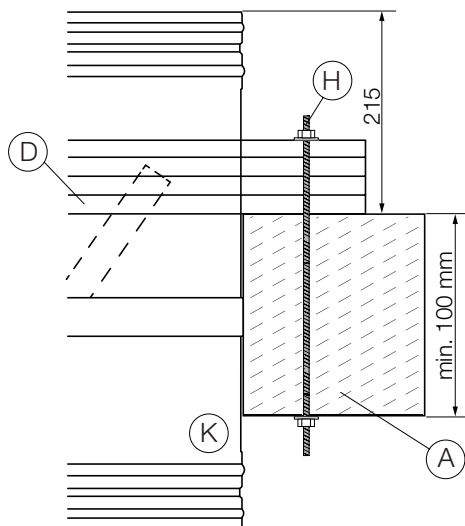

Floor/ceiling installation

Actuator down

- A Rigid floor/ceiling according to pg.18
- D MF installation kit
- H 4pcs of M6 threaded rods trough ceiling and tightened with M6 nut/counternut from both sides
- K Fire damper casing

Classification

FDC40 MF2: EI 90 (ve i↔o)S



DOP



WALLS



MATERIALS

Possible damper orientations



0-360°

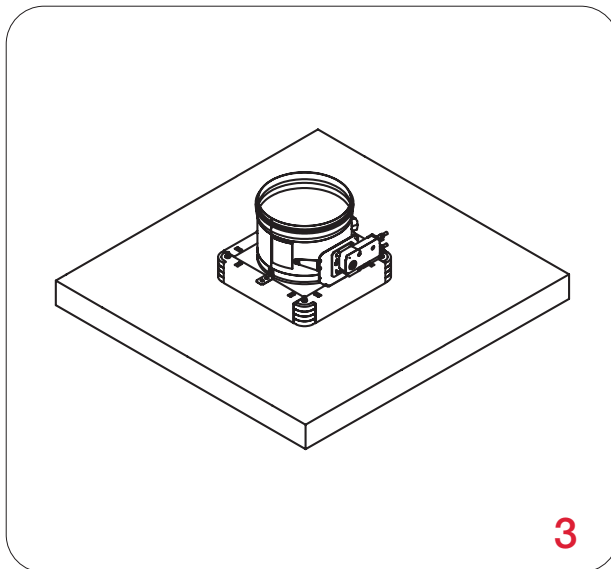
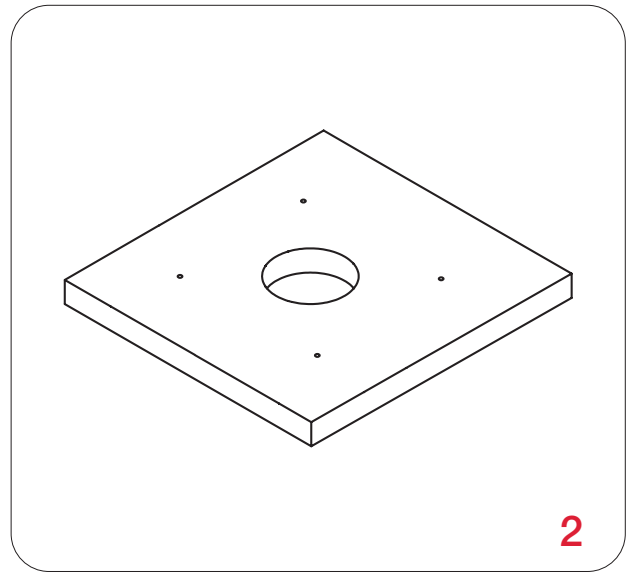
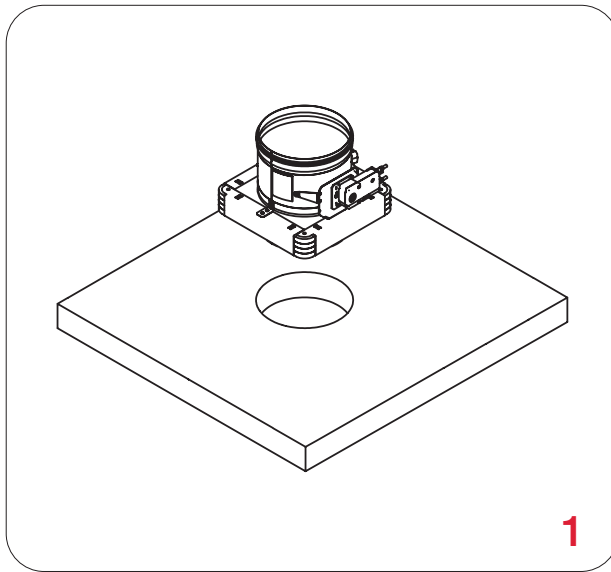

Damper blade must be closed during installation!

1. Create an opening in the floor/ceiling (FDC25- Ød +10 mm, FDC40-Ød + 25 mm). Insert the fire damper into the opening and mark the places for drilling holes.

2. Remove the fire damper and drill the marked places (8 mm).

3. Mount 4/12 sets of pre-cut threaded rods, washer, nut and counternut on one side. Place pre-assembled threaded rods in holes in floor/ceiling, and place the damper in the opening. Tighten the tightening sets from opposite side with washer, nut and counternut.

Test the operation of the damper blade!

Shaft wall installation

MF2 installation frame

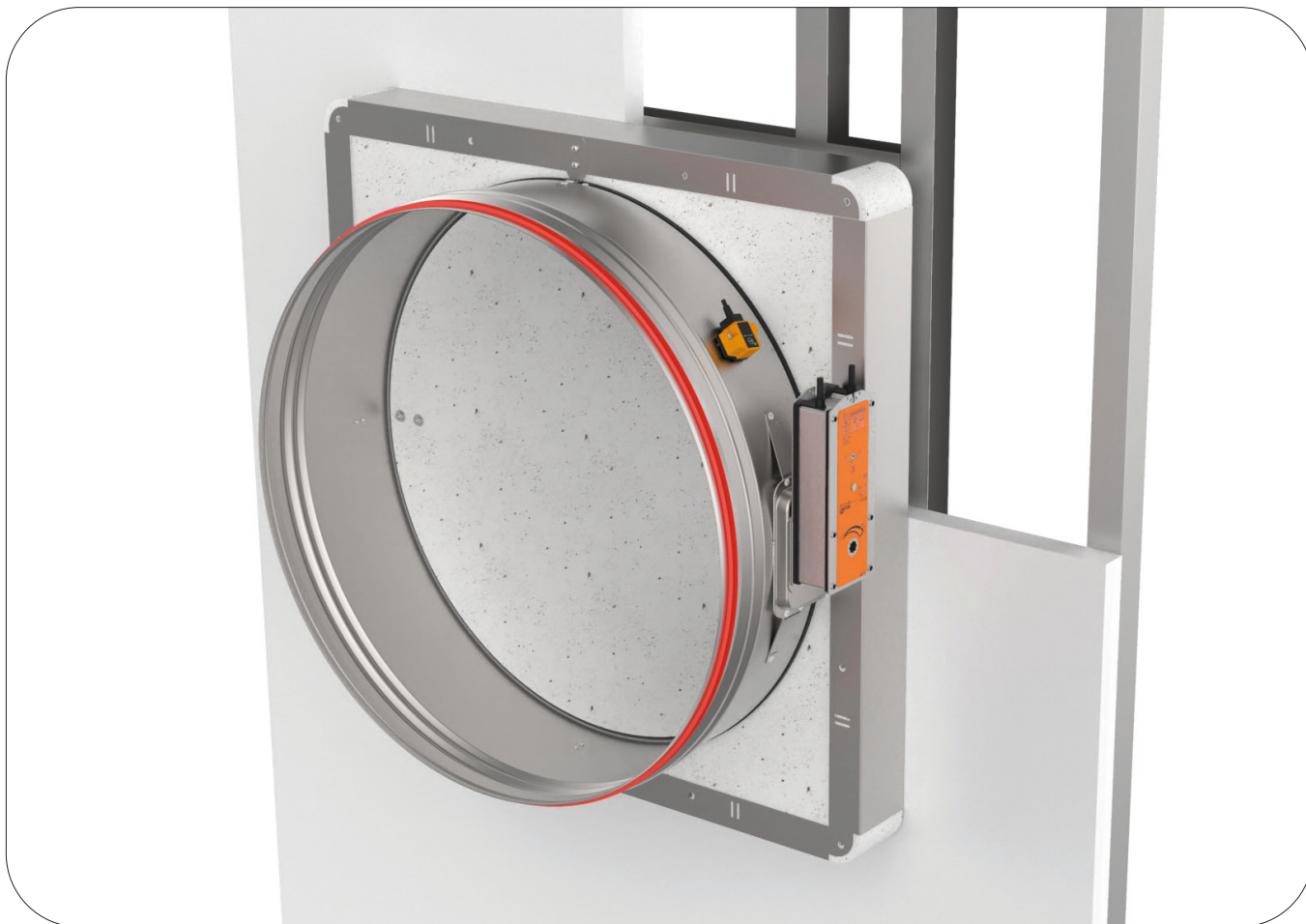

The wall is composed of 1x2 plasterboard boards, 12,5 mm / 20 mm thick, installed on a steel frame construction.

FDC25/FDC40 MF2 (EI 60 (ve i↔o)S) - 12,5 mm - GKF/Piano
 FDC25/FDC40 MF2 (EI 90 (ve i↔o)S) - 20 mm - Fireboard

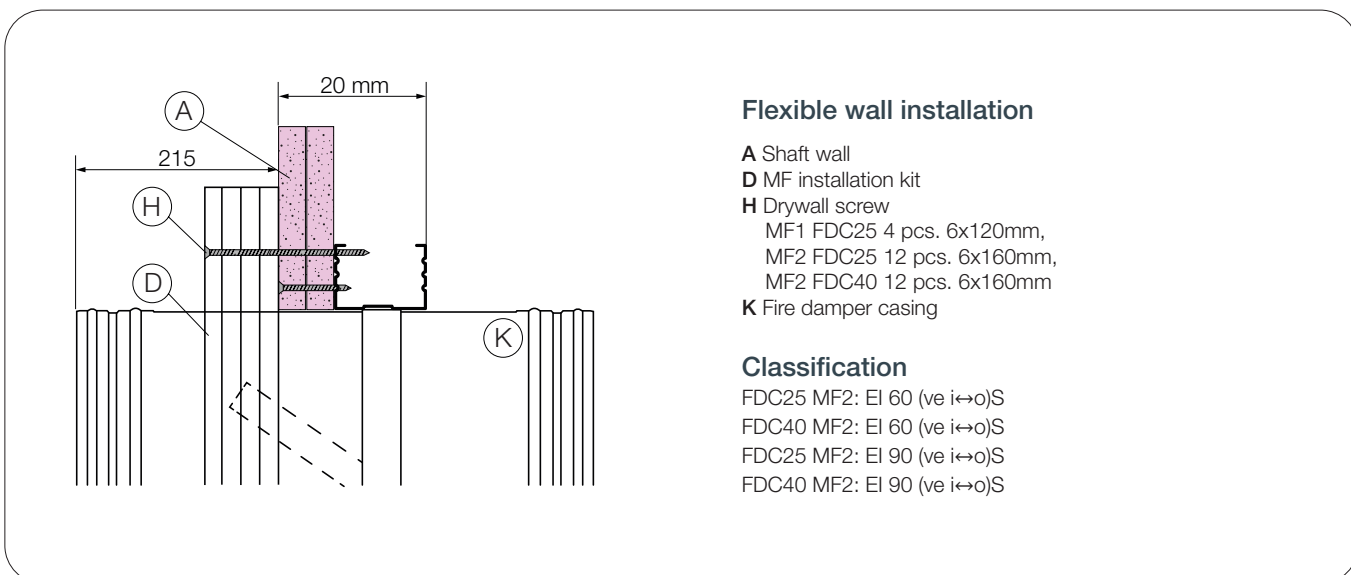



DOP



WALLS



MATERIALS

Possible damper orientations

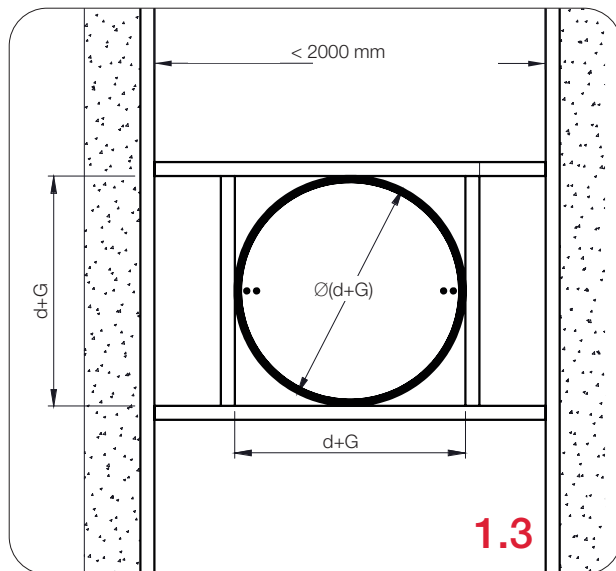
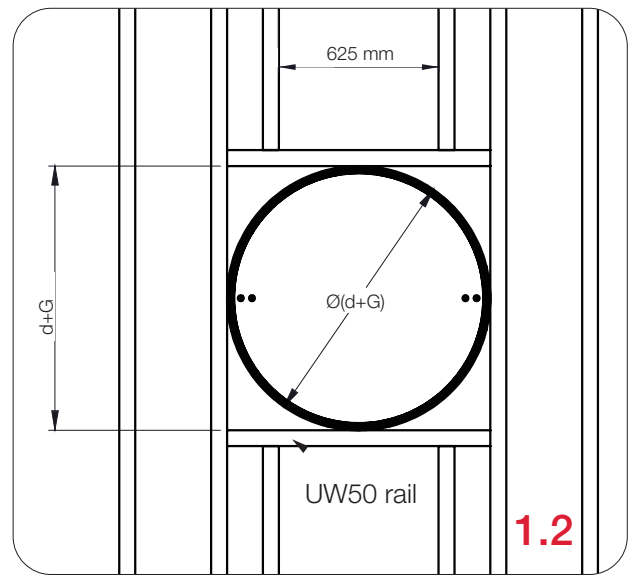
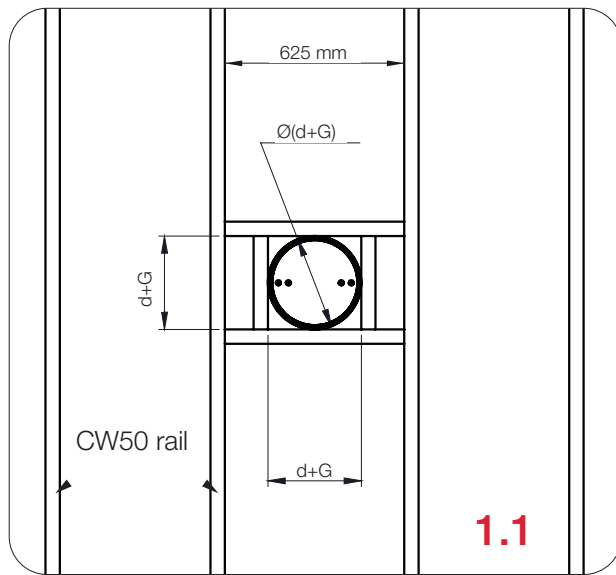

FDC25, FDC40 - side cross section

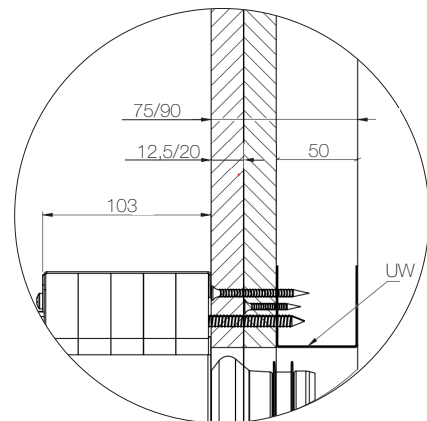

Damper blade must be closed during installation!

- (1.1) For fire dampers $\text{Ø}d < 625 \text{ mm}$, make a steel subframe according to drawing
- (1.2). For fire dampers $\text{Ø}d > 625 \text{ mm}$, make a steel subframe according to drawing.
- (1.3) For installation in shaft walls without metal studs, make a steel subframe according to drawing.

2. Place the fire damper in the opening.
3. Insert fire damper into wall and fasten with screws (12pcs, 6x160 mm).

Test the operation of the damper blade!

* Dimension G depending of the damper type is:
 G=10 mm for FDC25
 G=25 mm for FDC40

Installation remote from flexible/rigid wall FDC 25

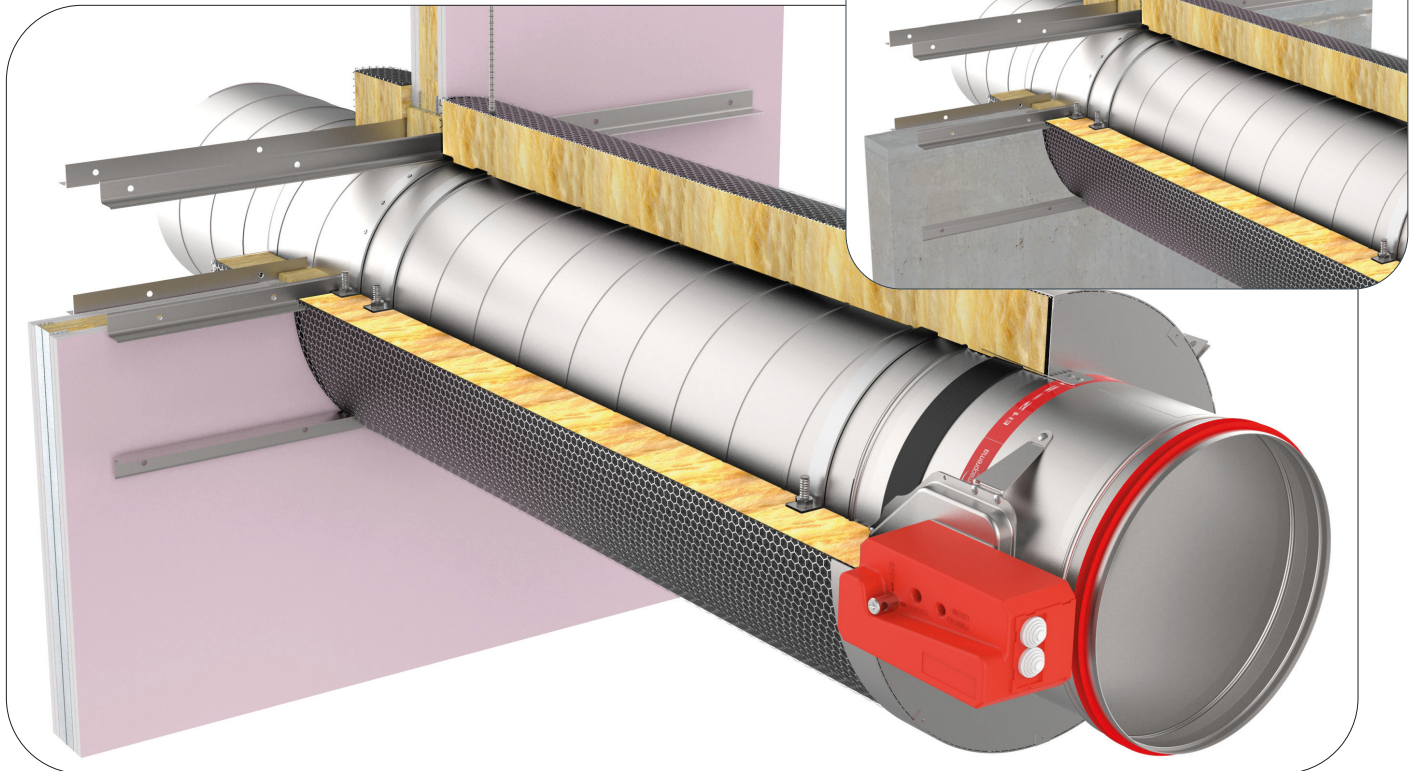

Flexible wall: The wall is composed of 2x2 plasterboard boards, 12,5 mm thick, installed on a steel frame construction. To fulfill the classification it is **NOT** mandatory to use the mineral wool inside the wall (mineral wool with density up to 115 kg/m³ can be used). The minimum thickness of the wall is 100 mm.

Rigid wall: The wall is composed of concrete blocks (minimum density of 450 kg/m³) or reinforced concrete (minimum density of 2200 kg/m³) and with a minimum thickness of 100 mm.

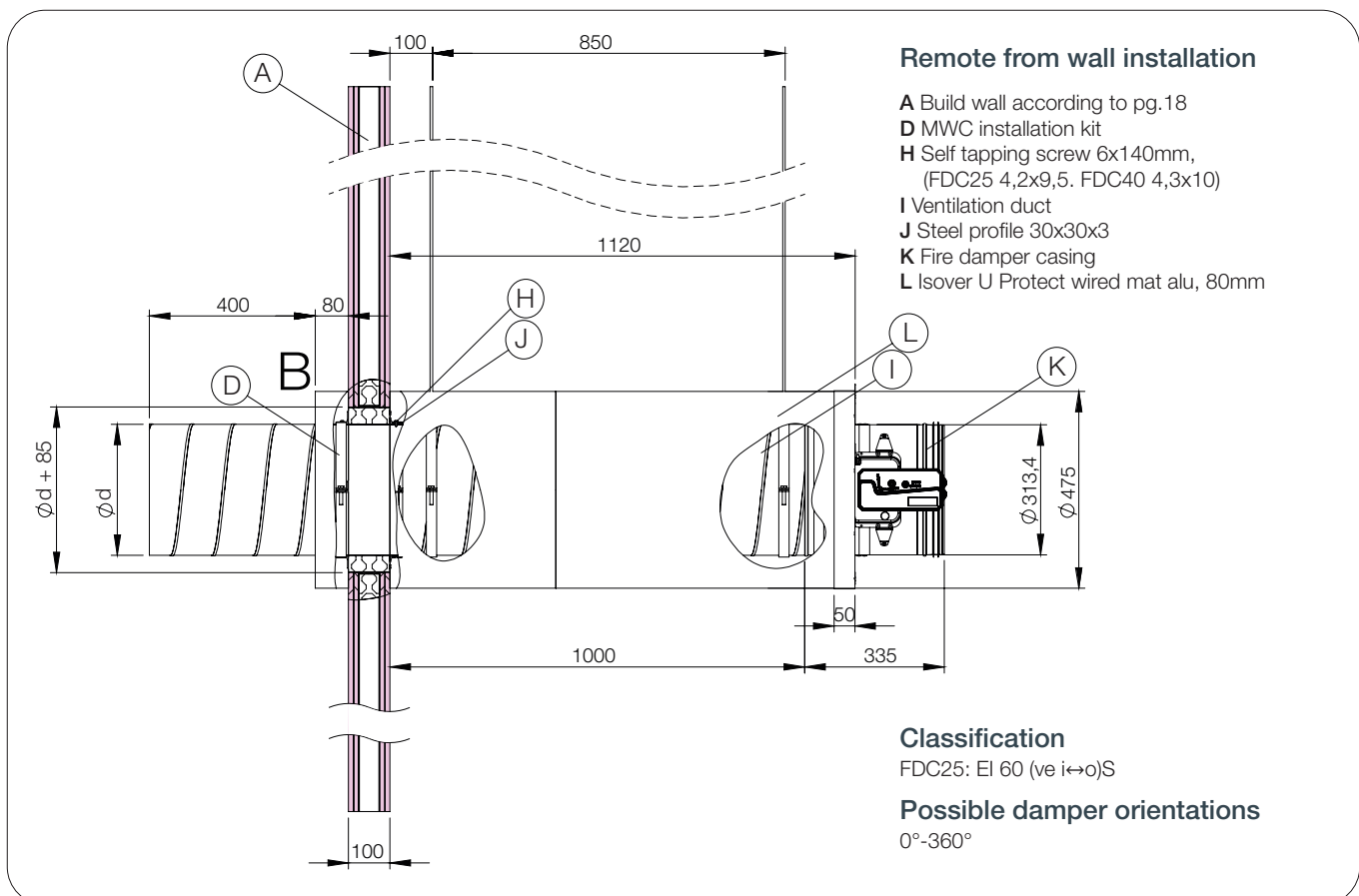



Technical drawing
FDC 25



DOP



WALLS



MATERIALS

Possible damper orientations

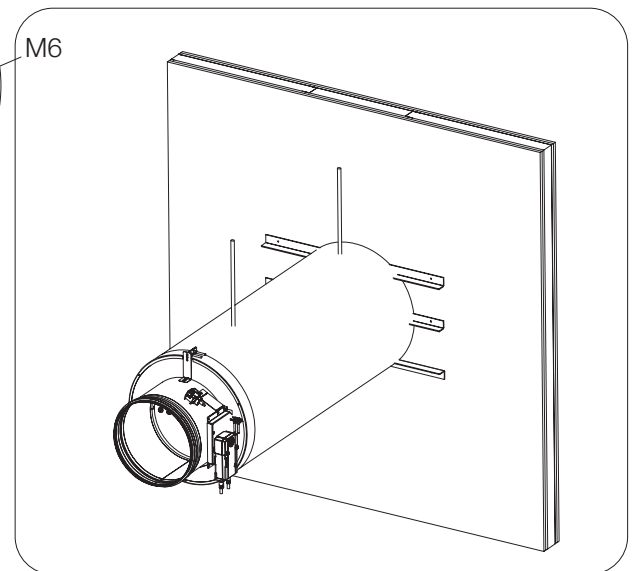
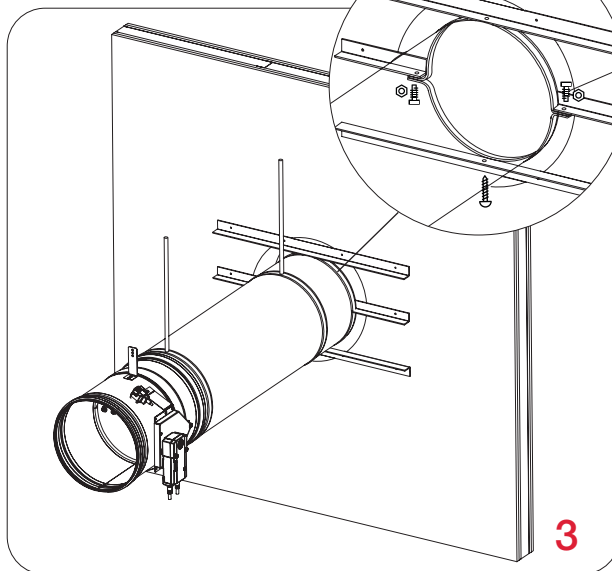
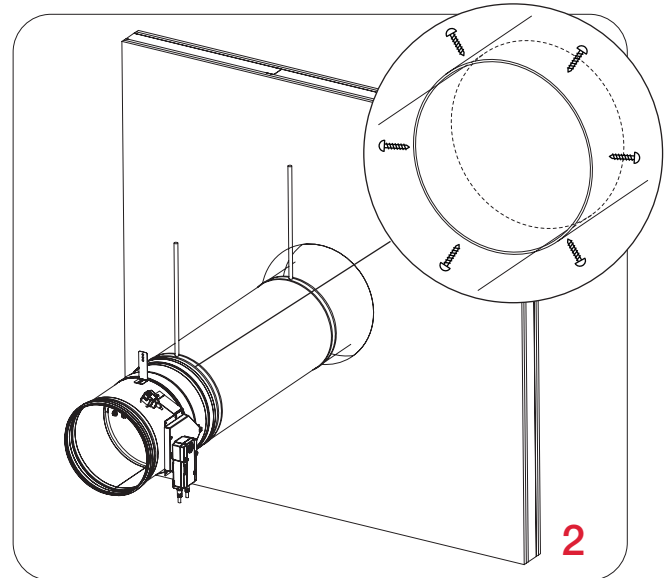
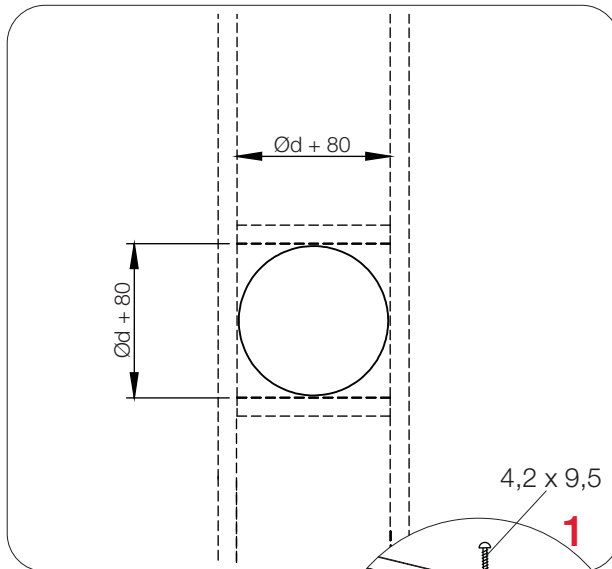

Damper blade must be closed during installation!

1. Place the damper in an opening according to the picture. Place ventilation duct trough wall (thickness of threaded rod for suspension should be M10)
2. Install fire damper and secure it with self-tapping screws 4,2x9,5 to duct (every 300 mm max). Fill space between duct and wall with mineral wool (Isover U protect Wired Mat Alu 1, min. 80 mm thickness). Additionally paint wool with Isover BSF in thickness of 2 mm on both sides.
3. Close installation with L profiles 30x30x3 mm. Additionally fix profiles to duct with self-tapping screws, and screw them to wall with 4,5x50 screws with 200 mm distance between them. On connection wool-wall apply glue Isover BSK in thickness of 2 mm. Repeat the same procedure on the other side. Place the wool on ventilation duct in length of 80 mm
4. Place steel protection on place where insulation on damper ends (80x80 mm, 1 mm thick metal sheet cover)

Max. dimension for this installation $\text{Ød } 315$
*Use MWC accessories kit for installation!

Test the operation of the damper blade!

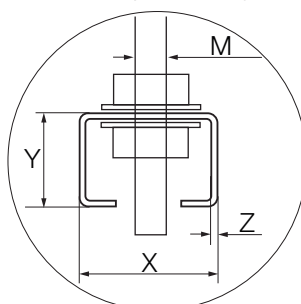

Suspension dimensions	X	Y	Z	M
FDC25	30	30	3	M10

Installation remote from flexible/rigid wall FDC 40

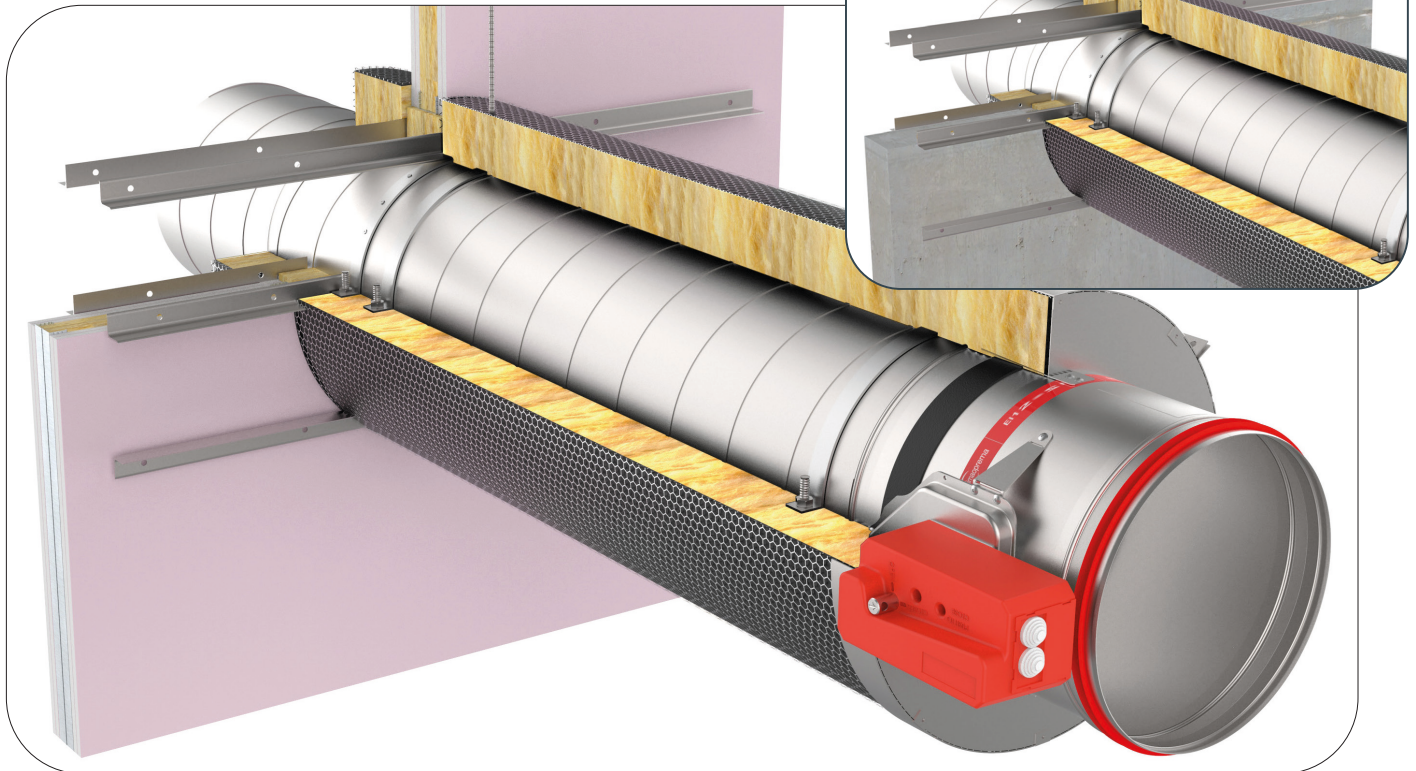

Flexible wall: The wall is composed of 2x2 plasterboard boards, 12,5 mm thick, installed on a steel frame construction. To fulfill the classification it is **NOT** mandatory to use the mineral wool inside the wall (mineral wool with density up to 60 kg/m³ can be used). The minimum thickness of the wall is 100 mm.

Rigid wall: The wall is composed of concrete blocks (minimum density of 450 kg/m³) or reinforced concrete (minimum density of 2200 kg/m³) and with a minimum thickness of 100 mm.

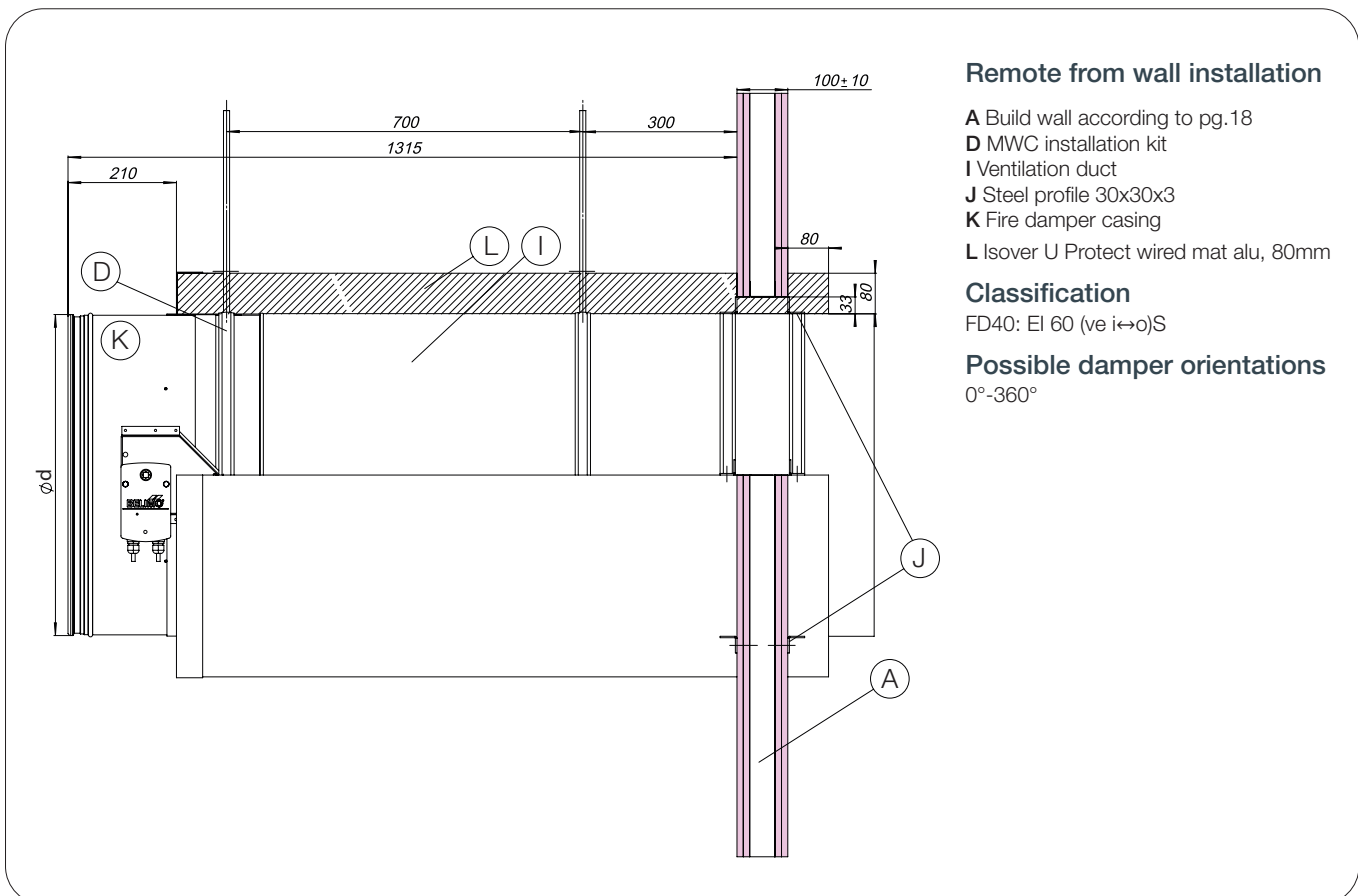



Technical drawing
FDC 40



DOP



WALLS



MATERIALS

Possible damper orientations

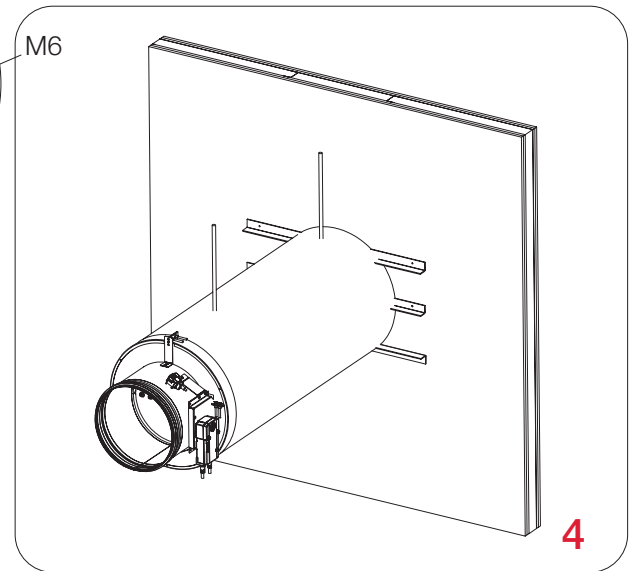
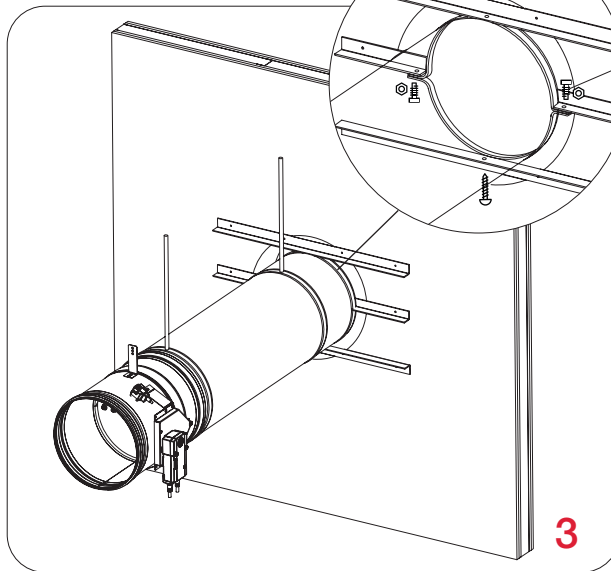
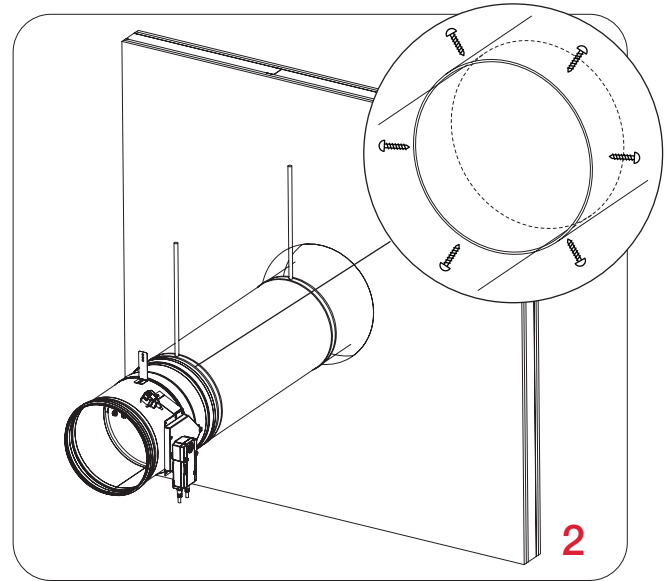
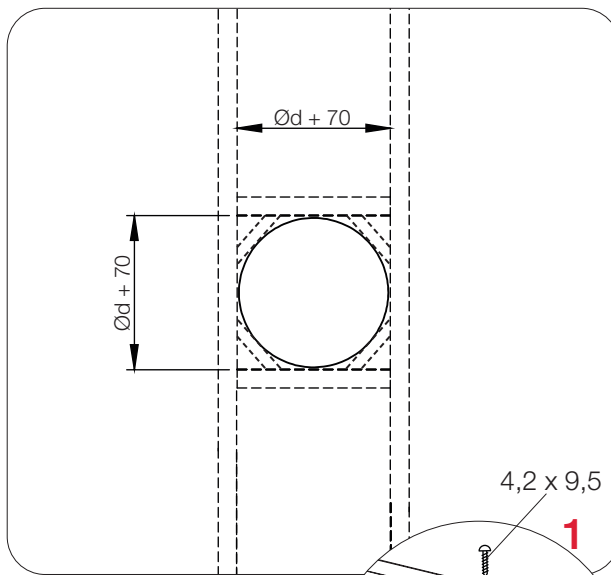

Damper blade must be closed during installation!

1. Place the damper in an opening according to the picture. Place ventilation duct trough wall (thickness of threaded rod for suspension should be M12)
2. Install fire damper and secure it with self-tapping screws 4,3x10 to duct (every 300 mm max). Fill space between duct and wall with mineral wool (Isover U protect Wired Mat Alu 1, min. 80 mm thickness). Additionally paint wool with Isover BSF in thickness of 2 mm on both sides.
3. Close installation with L profiles 30x30x3 mm. Additionally fix profiles to duct with self-tapping screws, and screw them to wall with 4,5x50 screws with 200 mm distance between them. On connection wool-wall apply glue Isover BSK in thickness of 2 mm. Repeat the same procedure on the other side. Place the wool on ventilation duct in length of 80 mm
4. Place steel protection on place where insulation on damper ends (80x80 mm, 1 mm thick metal sheet cover)

Max. dimension for this installation $\varnothing d$ 630

***Use MWC accessories kit for installation!**

Test the operation of the damper blade!

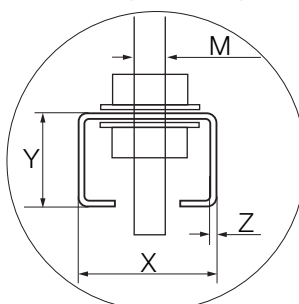

Suspension dimensions	X	Y	Z	M
FDC40	30	30	3	M12

* The images shown are for illustration purposes only and may not be an exact representation of the product.

Multiple fire dampers installation

Damper blade must be closed during installation!



Weichschott/Firebatt - Mineral wool

1*. Prepare opening in the wall according to the installation type. (Weichschott/Firebatt installation- build the subframe according to the drawing see page 15.

Mortar - Gypsum blocks

1. Prepare opening in the wall according to the installation. Fire damper can be installed with minimal distance of 30 mm between wall/ceiling and 30 mm from other dampers.
2. Insert the fire dampers into the wall and fill the space between the dampers and between dampers and wall with material specified in DOP, [see page 20](#).
3. In case of weichschott/firebatt installation fill the space between the dampers and between the dampers and ceiling with coated mineral wool up to flanges.
4. Complete the installation according to the assembly instructions for the particular installation. Mineral wool and damper casing must be coated with 2 mm thick fire protection coating. Damper casing should be coated up to profile protrusions.

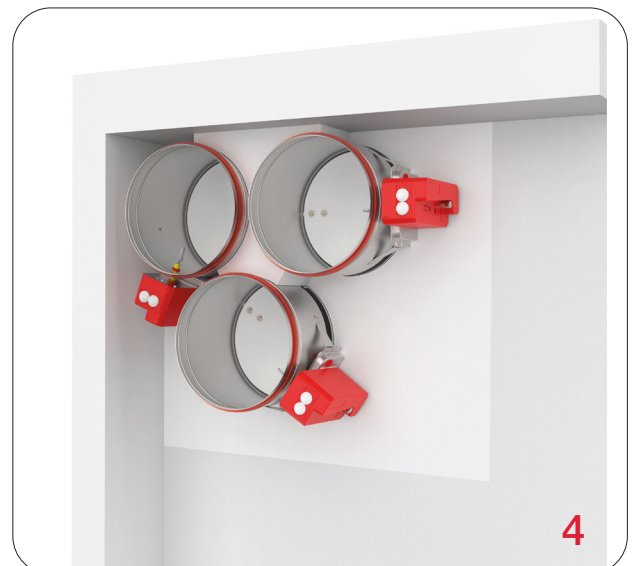
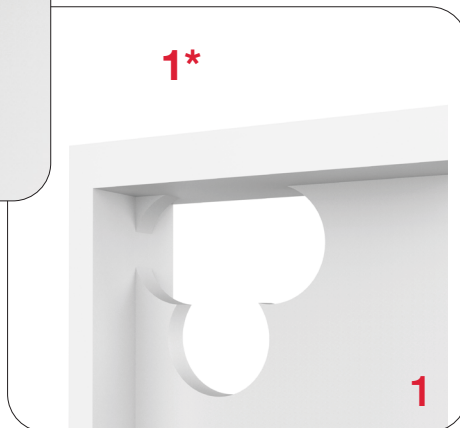



DOP



WALLS



MATERIALS

- Material in width of supporting constructions compliant with the classification from [DOP](#)
- *Coated mineral wool 240 mm wide (140 kg/m³) only in case of weichschott/firebatt

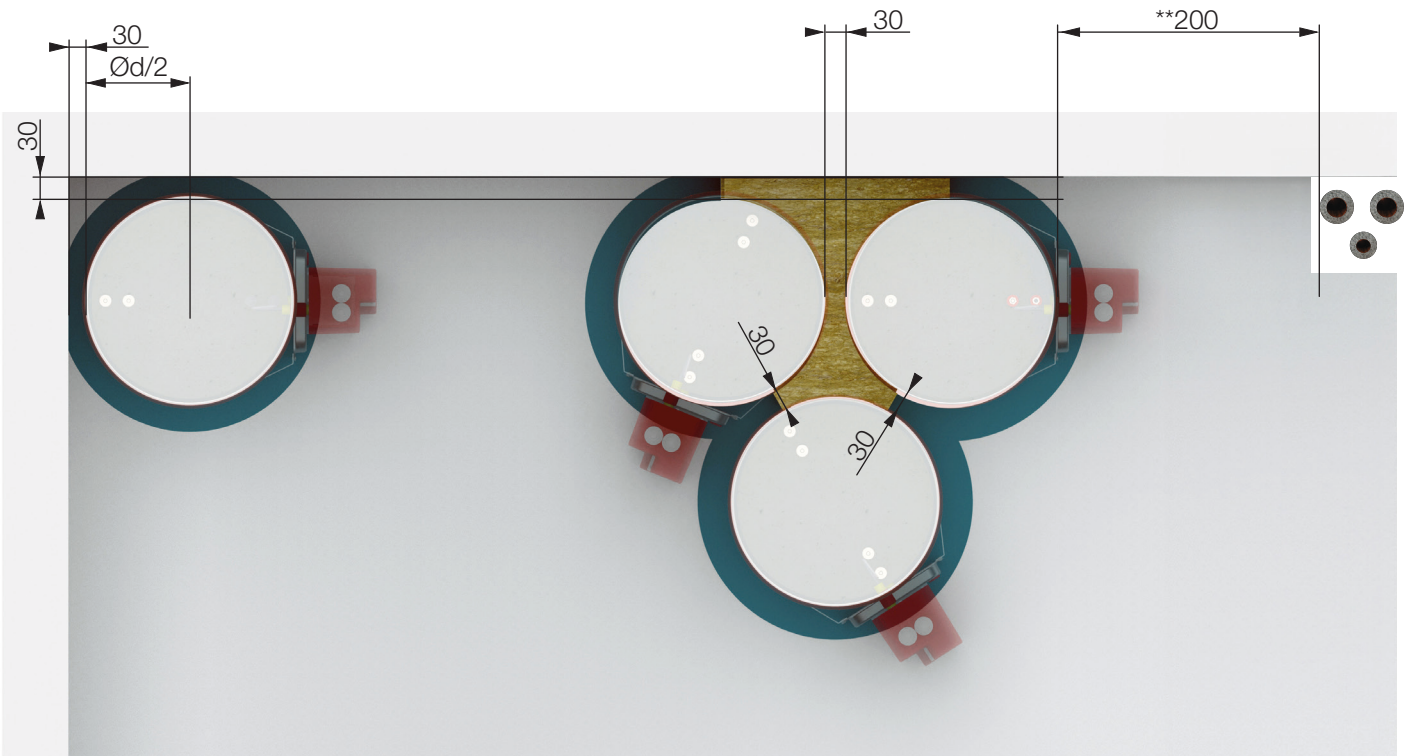

- * Minimal distances from another damper or wall/ceiling.
- ** Minimal distances from any other penetration through the wall.

Accessories

1 **FD-A-CSP GKF boards for dry installation** - Calcium silicate plates are used in dry installations as insulation cover. It keeps the insulation in place and provides for better fire penetration characteristics of the whole installation. Cover the complete perimeter around fire damper from both sides with boards in 150 mm height.

2 **FD-A-FLEX Flexible duct connections** - Flexible duct connectors are used in HVAC systems for isolation from structure-borne noise, expansion compensation and fire damper connections (total length 130 mm, flexible 70mm).

3 **FD-A-SG Safety grill**- Safety grill is used for protection of the fire damper and duct from large debris. Safety grille is produced out of galvanized steel and perforated with square 10x10mm perforation providing approx. 70% free cross section area. Fire damper, safety grille and, if applicable, extension piece are assembled at the factory to form a unit. FD-A-SG1-operation side, FD-A-SG2-installation side

4 **FD-A-CMB Communication module bracket** - is used when the height of the fire damper is more than 350mm and damper blade in open position is protruding out of the casing.

5 **FD-A-IH Inspection hatch** - is used for performing regular visual functionality inspection checks.

6 **FD-BP-KIT Thermal fuse blanking plate**- is used for covering the thermal fuse hole on the casing in case of changing from the motor to the manual actuator. Installation with performed with 2 self-taping screws

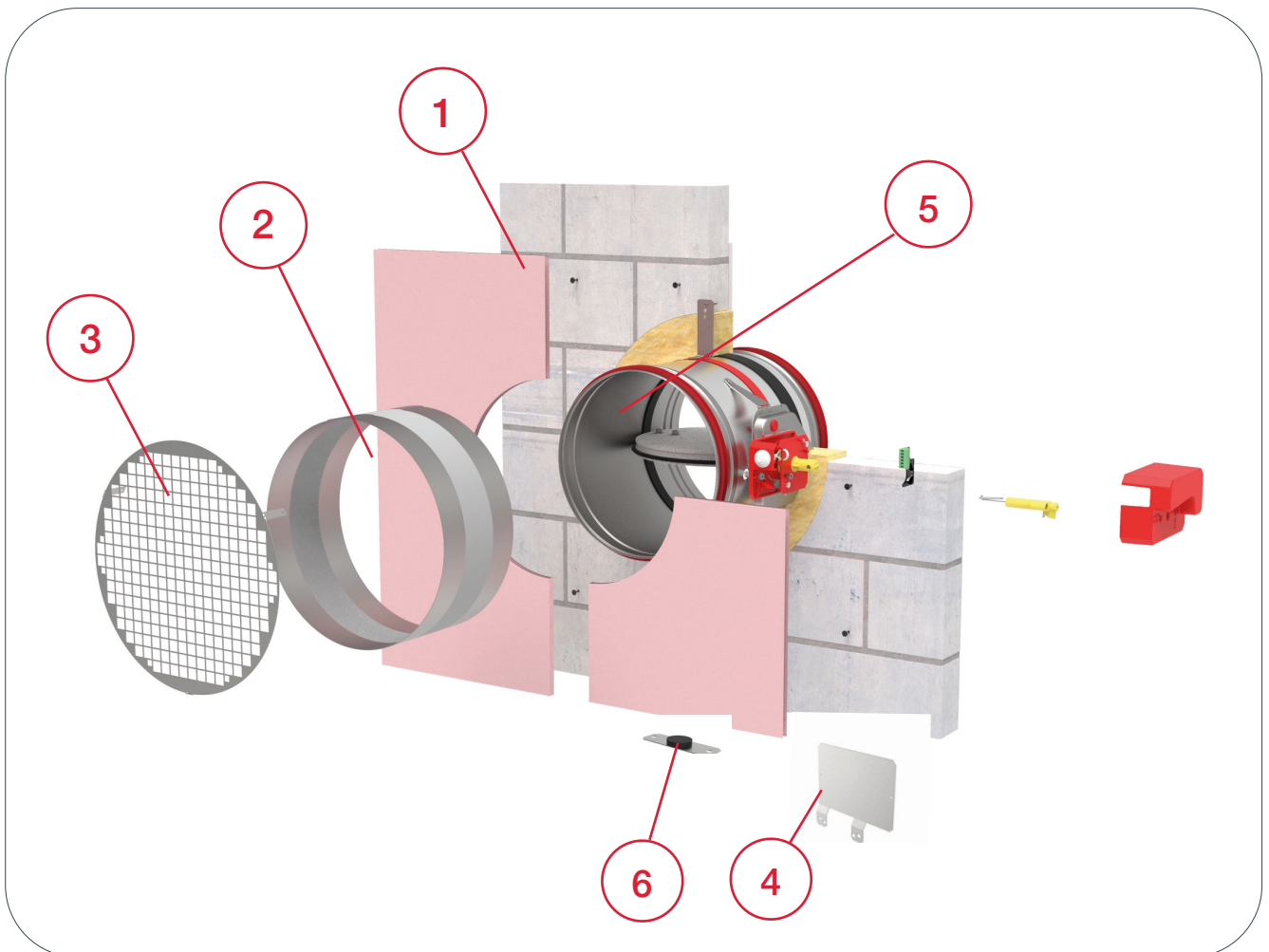



DOP



WALLS



MATERIALS

- 7 **MWC** Mineral wool cover (for remote installation) - MWC kit,
 - Steel 1,0 mm
 - Galvanised

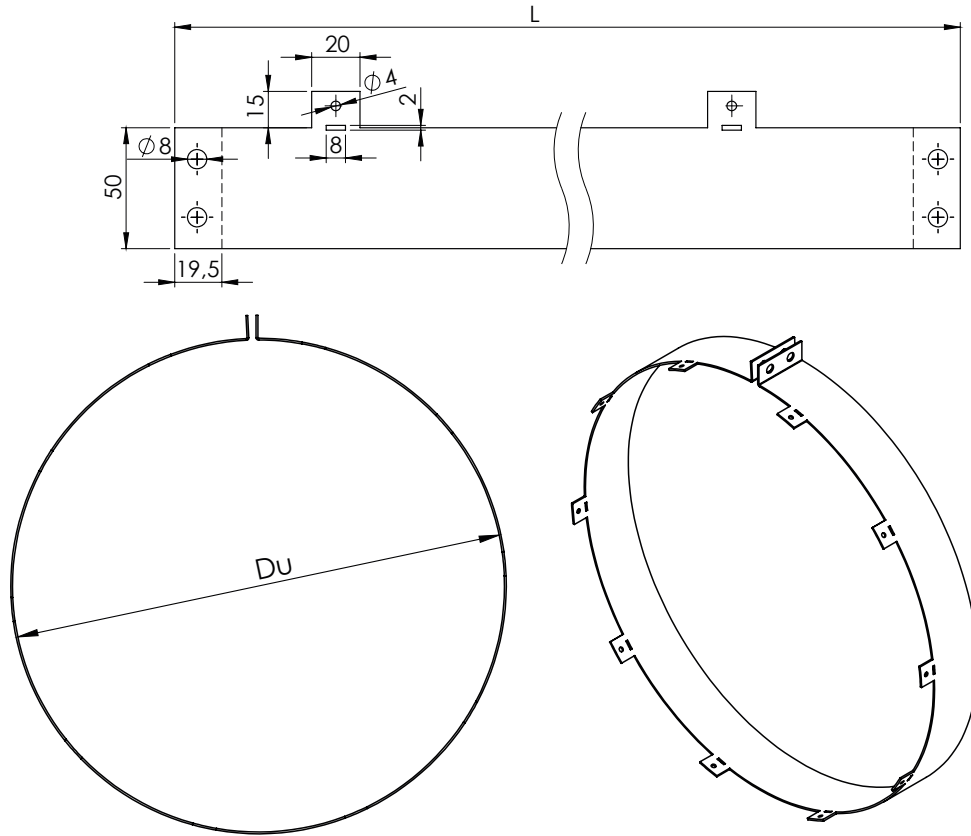

FDC	Du	L
100	256,6	844
125	281,6	922
160	316,6	1032
200	356,6	1157
250	406,6	1313
300	456,6	1470
315	471,6	1519
350	506,6	1628
355	511,5	1644
400	556,6	1785
450	606,6	1941
500	656,6	2100
630	786,6	2507
710	866,6	2759
800	956,6	3040

* The images shown are for illustration purposes only and may not be an exact representation of the product.

Spare parts

For safety reasons, parts need to be changed by a trained personnel or the manufacturer.

WARNING! Install the original parts only!

1. **FD-A-THERM-72** Fuse kit
2. **FD-A-R25S-KIT** Double contact S kit
3. **FD-A-R40S-KIT** Double contact S kit
4. **FD-A-EMS-KIT** Solenoid actuator
5. **FD-A-BAT72** Belimo thermal fuse 72°C
6. **FD-A-ZBAT95** Belimo thermal fuse 95°C
7. **Belimo BFL Kit A** Upgrade to electric actuator (Belimo BFL)
8. **Belimo BFN Kit B** Upgrade to electric actuator (Belimo BFN)
9. **Belimo BF Kit C** Upgrade to electric actuator (Belimo BF)
10. **FD-A-R40** R40 manual mechanism
11. **FD-A-ERK** Electric actuator rotation kit
12. **FD-SSA** Smoke sensor
13. **MWC** Mineral wool cover (for remote installation)

1



2

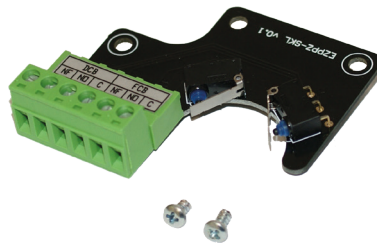

3

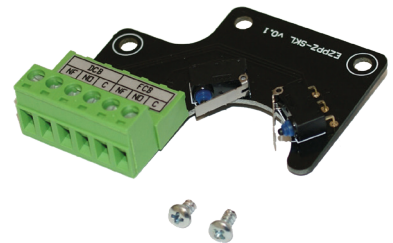

4

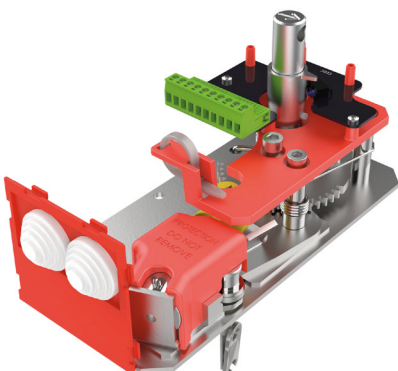

5



6





DOP



WALLS



MATERIALS

7



8



8



9



10



11

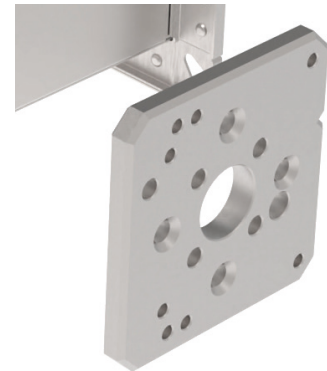

12



* The images shown are for illustration purposes only and may not be an exact representation of the product.

MANUAL ACTUATORS

R, R-S

Manual operating mechanism, optionally with end switches (R-S). In case of fire, the fire damper closes automatically. Damper closing can be initiated either by thermal fuse melting, or by manual activation on the operating mechanism. Upon closure, damper blade is locked in closed position and can only be opened manually. Thermal fuse melting point is 72 °C.

R25

R25 manual actuator is installed on FD25 fire dampers range from 100x200 till 800x600. It is available in version with (R-S) and without (R) end switches. End switches and thermal fuse are easily replaceable and available as service parts.

To upgrade to EMS, upgrade of R25 to R40 is required.

R40

R40 manual actuator is installed on FD40 fire dampers from 800x600 till 1500x800. It is available in version with (R-S) and without (R) end switches. In case remote activation is needed, R40 actuator is easily upgradeable to electromagnetic EMS-S actuator with installation of the electromagnet. End switches, thermal fuse and electromagnet are easily replaceable and available as service parts.

Technical specifications

Nominal voltage	N/A
Power	N/A
Switching capacity	1mA...500mA, 5VDC...48VDC
Blade closing time	Spring: 1 sec
Blade opening time	Manual
Manual activation	Release button on the casing
Degree of protection	IP 42
Ambient temperature range	min. -30 °C, max. 50 °C
Ambient humidity	95% r.h., non-condensing
Service life	Min. 30,000 cycles
Maintenance	Maintenance-free
Weight R25/R40	0,5 kg / 1,7 kg

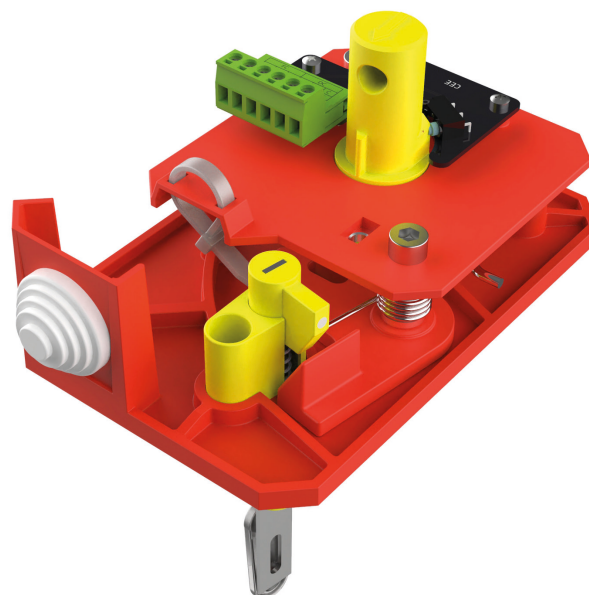

Wiring diagram

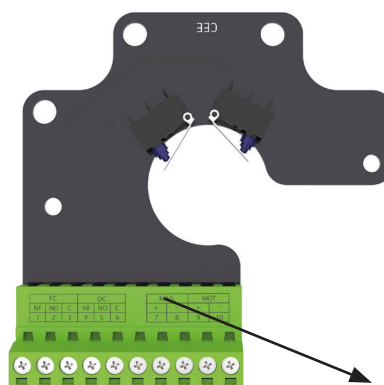

FC			DC		
NC	NO	C	NC	NO	C
11	12	13	14	15	16

FC = Limit switch - end
 DC = Limit switch - start
 NO = normally open
 NC = normally closed
 C = common

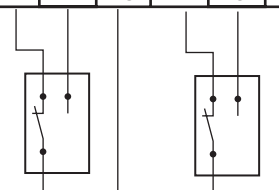

SOLENOID ACTUATOR EMS-S

Electromagnetic operating mechanism, comes with end switches as standard. In case of fire, the fire damper closes automatically. Damper closing can be initiated either by thermal fuse melting or remotely by triggering the electromagnet. Electromagnet is constantly under power and activates closing of the damper blade in case the power cuts out. Upon closure, damper blade is locked in closed position and can only be opened manually. Thermal fuse melting point is 72 °C. EMS-S mechanism is the same for FDC25/ FDC40 fire dampers.



Technical specifications

Nominal voltage	Solenoid: 24/48 VDC
Power	Dual voltage SOLENOID: Break of current: P _{nom} = 1.6W
Switching capacity	1 mA...500 mA, 5 VDC...48 VDC
Blade closing time	Spring: 1 sec
Blade opening time	Manual
Manual activation	Release button on the casing
Degree of protection	IP 42
Ambient temperature range	min. -30 °C, max. 50 °C
Ambient humidity	95% r.h., non-condensing
Service life	Min. 30,000 cycles
Maintenance	Maintenance-free
Weight	2,2 kg

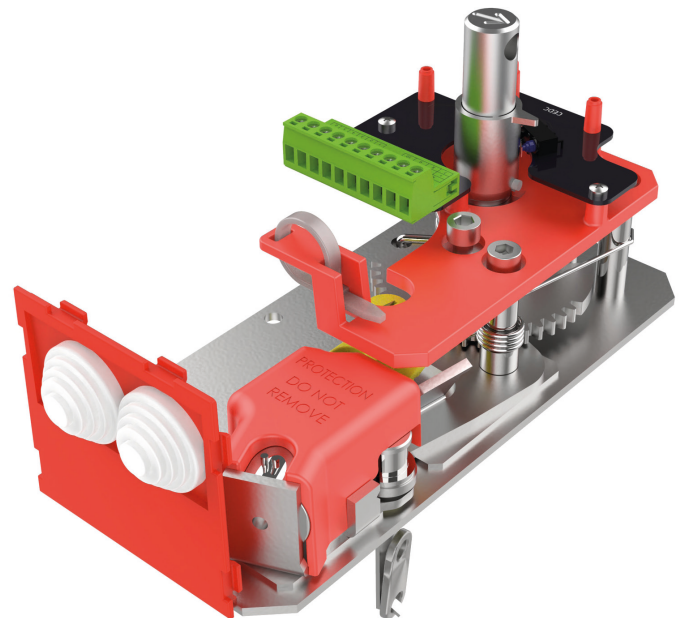

Wiring diagram

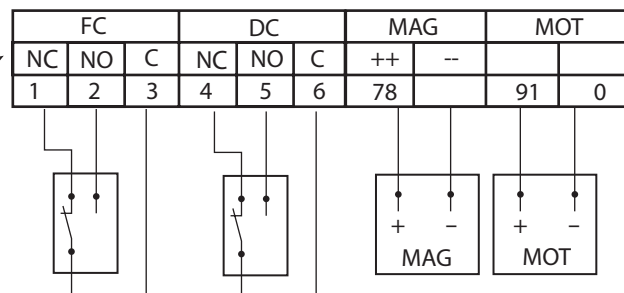
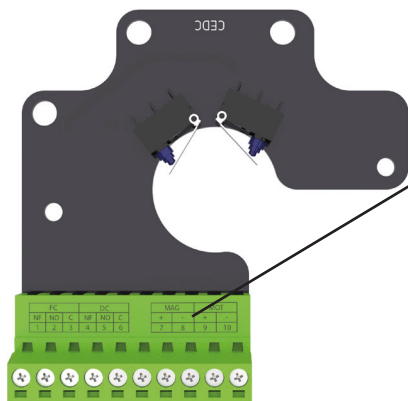

FC = Limit switch - end
 DC = Limit switch - start
 NO = normally open
 NC = normally closed
 C = common

* The images shown are for illustration purposes only and may not be an exact representation of the product.

ELECTRIC ACTUATOR

M24-S, M230-S, M230-SST, M24-S-ST

Damper is delivered in closed position. When electric actuator is connected to the power supply damper will open. When the damper reaches the end position (damper open), the electro motor will stop. Closing fire damper takes place automatically when a power failure occurs. Thermal tripping device that comes with fire damper causes power circuit break at a temperature of 72 °C, optional 95 °C (inside or outside duct). If checking is needed for proper functioning of fire damper, pushing the switch on the thermal tripping device will close damper.

When switch on tripping device is released, the damper will open. Damper can be opened without connecting to a voltage with enclosed handle turning in the direction of the arrow on electric actuator (clockwise). Damper can be locked in the desired position by fast turning back handle a quarter of a turn (counter clockwise) for Belimo BF, and by pulling brake on Belimo BFL and BFN.

To unlock the electro motor, turn handle clockwise for a quarter of a turn for Belimo BF, or release brake for Belimo BFL and BFN. After release, damper will be closed by return spring. When damper is opened manually, electric actuator will not move the damper into closed position in case of power failure.



Technical specifications

Type of Belimo actuator	BFL24-T	BFN24-T	BFL230-T	BFN230-T	BF24-T	BF230-T	
voltage	AC/DC 24 V, 50/60 Hz	AC 24 V, 50/60 Hz	AC 230 V, 50/60 Hz	AC 230 V, 50/60 Hz	AC/DC 24 V, 50/60 Hz	AC 230 V, 50/60 Hz	
Nominal voltage / power	opening	2,5 W	4 W	3,5 W	5 W	7 W	8.5 W
	holding	0,8 W	1,4 W	1,1 W	2,1 W	2 W	3 W
for wire sizing	4 VA	6 VA	6,5 VA	10 VA	10 VA	11 VA	
End switch	1 mA...3 A (0,5 A), DC 5 V...AC 250V	1 mA...3 A (0,5 A), DC 5 V...AC 250 V	1 mA...3 A (0,5 A), DC 5 V...AC 250 V	1 mA...3 A (0,5 A), DC 5 V...AC 250 V	1 mA...6 A (3 A), DC 5 V...AC 250 V	1 mA...3 A (0,5 A), DC 5 V...AC 250 V	
Running time	motor	< 60 s	< 60 s	< 60 s	< 60 s	< 120 s	< 120 s
	spring return	~ 20 s	~ 20 s	~ 20 s	~ 20 s	~16 s	~16 s
Ambient temperature range	min. -30 °C, max. 50 °C						

Wiring diagram

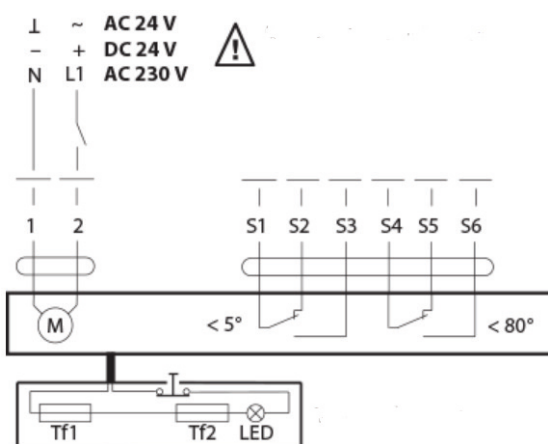

- 1 negative (direct-current) or neutral (alternating current)
- 2 positive (direct-current) or faze (alternating current)
- S1 common micro switch closed damper
- S2 normally closed micro switch closed damper
- S3 normally open micro switch closed damper
- S4 common micro switch open damper
- S5 normally closed micro switch open damper
- S6 normally open micro switch open damper
- Tf temperature sensor on the outer side of the duct (ambient temperature) max. 72 °C

ELECTRIC ACTUATOR SCHISCHEK ExMax

Damper is delivered in closed position. When electric actuator is connected to the power supply damper will open. When the damper reaches the end position(damper open), in which is it blocked, the electric actuator will stop. Closing fire damper takes place automatically when a power failure occurs. Thermal tripping device that comes with fire damper causes power circuit break at a temperature of 72 °C (inside or outside duct). If checking is needed for proper functioning of fire damper, pushing the switch on the thermal tripping device will close damper. When switch on tripping device is released, the damper will open.

Damper can be opened without connecting to a voltage with enclosed Allen key, by turning in the direction of the arrow on electric actuator (clockwise). After release of Allen key, damper will go to closed position.

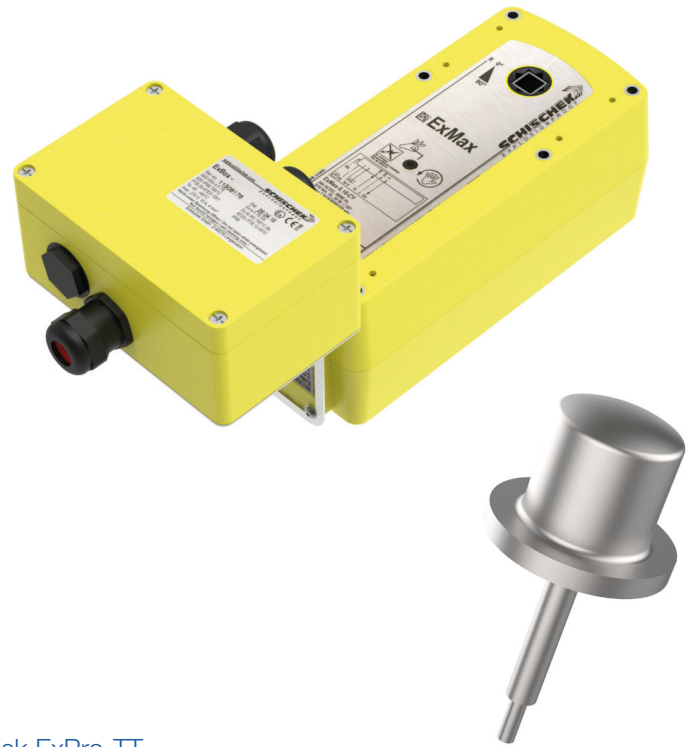

- 1) [Tecnical documentation Safety temperature trigger Schischek ExPro-TT](#)
- 2) [Tecnical documentation electric actuator Schischek ExMax-5.10-BF](#)
- 3) [Tecnical documentation Ex-e terminal box ExBox-BF](#)

Technical specifications

Type	ExMax -5.10-BF
Torque	5/10 Nm
Power Supply	24-230 V AC/DC
Running time	3/15/30/60/120 s / 90°
Spring return	3 or 10s / 90°
Control mode	On-Off, 3 position
Feedback	2 x aux switches + Ex. tripping device
Ambient temperature range	min. -40 °C, max. 40 °C
Ambient humidity	0-90% r.h., non-condensing
Service life	Min. 10,000 cycles @ 10 s, min 1000 cycles @ 1s
Maintenance	Maintenance-free
Weight	3,5 kg

Wiring diagram

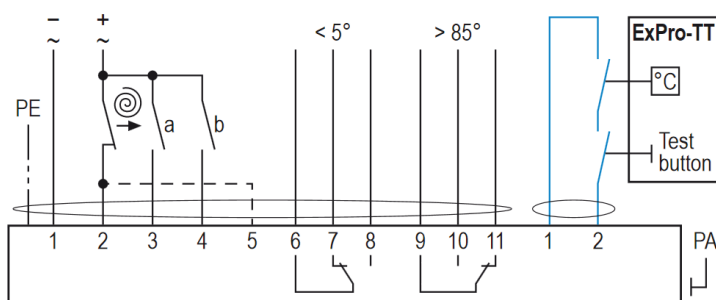

* The images shown are for illustration purposes only and may not be an exact representation of the product.

SMOKE SENSOR ASSEMBLY

FD-SSA-DIBt

Smoke sensor assembly is developed to detect smoke in ventilation ducts and combines a smoke detector and an adaptor system where both tube and housing are specially designed for optimum airflow through the smoke detector. Smoke sensor provides the signal for the fire damper which is activated when smoke is detected. Smoke sensor assembly consists of casing (length: 415 mm), smoke sensor and specially designed venturi pipe inside the duct.

For proper functioning of the smoke sensor (as it is physically connected as in the render above) a straight length of 5 times hydraulic diameter, in the size of the connecting duct, should be in front of the sensor. When the sensor is installed separate from the fire damper there are two conditions to be met:

- 1) Length of 5 times hydraulic diameter, in the size of the connecting duct, should be in front of the sensor.
 - 2) Length of 3 times hydraulic diameter, in the size of the connecting duct, should be after the sensor.
- $dh=(2xHxB)/(H+B)s$, dh - hydraulic duct diameter.

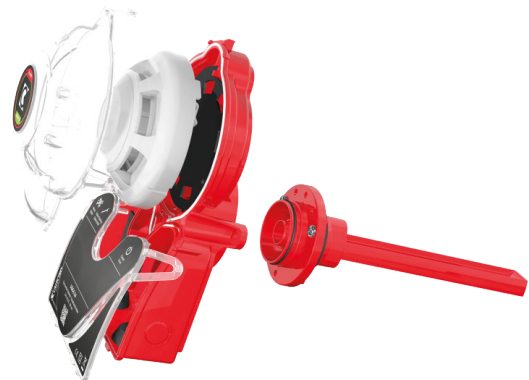

Technical specifications

	FD-A-UG-8-ZB-24	FD-A-UG-8-ZB-230
Voltage Supply	24V AC/DC ±10% Not polarity sensitive	230V AC ±10%, Not polarity sensitive
Detector type	Optical EVC-PR-DA	Optical EVC-PR-DA
Max. power consumption	85 mA (DC), 235 mA (AC)	100 mA
Operating temperature	-20°C to +55°C	
Maximum humidity	95% rH	
Duct air velocity range	1 to 20 m/s	
Approvals	VdS, CE, EN-54-27	
Relay output	Potential free	
Smoke alarm relays	One changing contacts 250V, 8A and one bracking contact 250V, (A	
Service alarm	One breaking contact 250V, 1A	
System error alarm	One breaking contact 250V, 1A	
Low Flow alarm:	One breaking contact 250V, 1A	
LED on smoke detector:	Yellow - service alarm(contamination) Red - smoke alarm	
LED on PCB:	Green - normal operation Yellow flashing - system error Yellow - Low-Flow	

Wiring diagram

FD-A-UG-8-ZB-24V (DIBt)

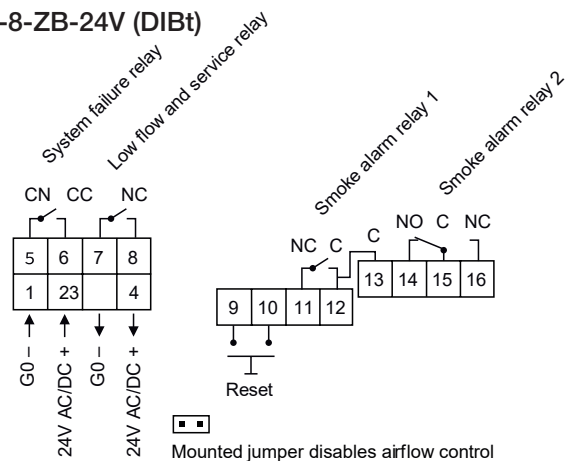

FD-A-UG-8-ZB-230V (DIBt)

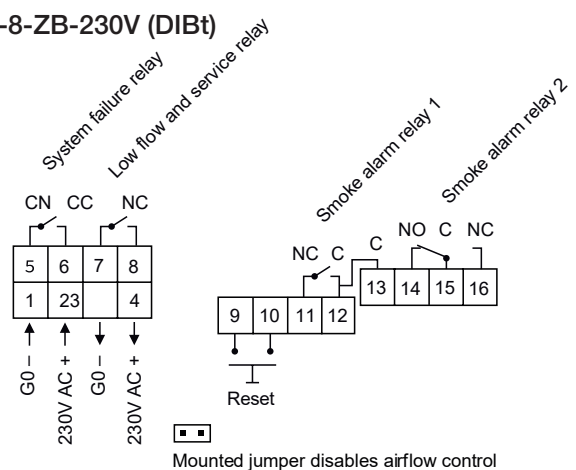

UPGRADE TO END CONTACTS (R25 → R25-S)



DOP



WALLS



MATERIALS

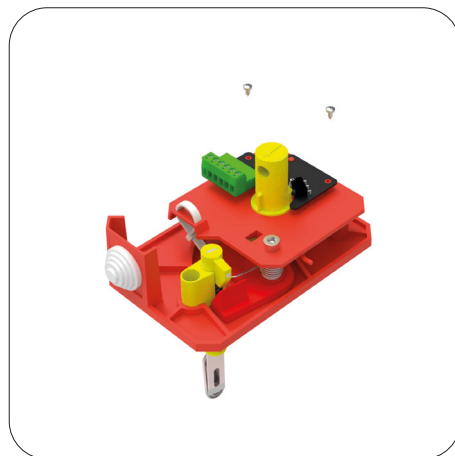
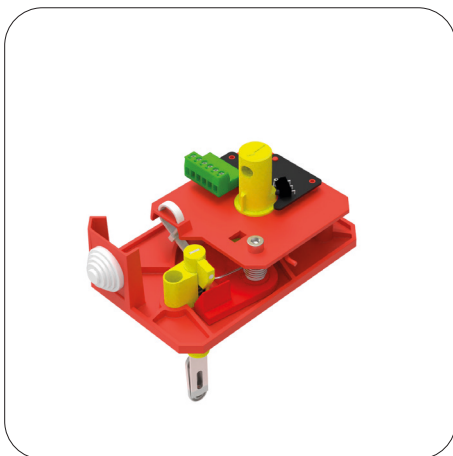
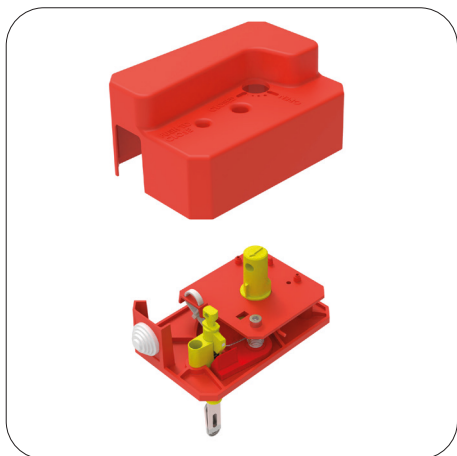

1. Locate hex screw, unscrew it and remove the cover.
2. Insert CEE (R25)/CEDC (R40) board in the appropriate place.
3. Screw the board to the plate. Put the cover back in place!

UPGRADE TO END CONTACTS (R40 → R40-S)

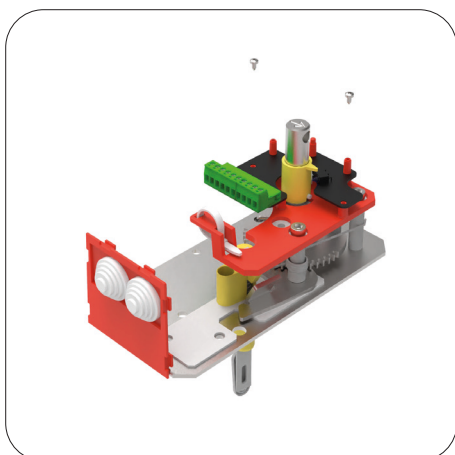
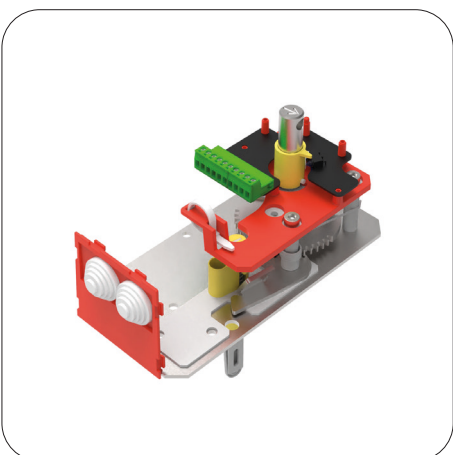
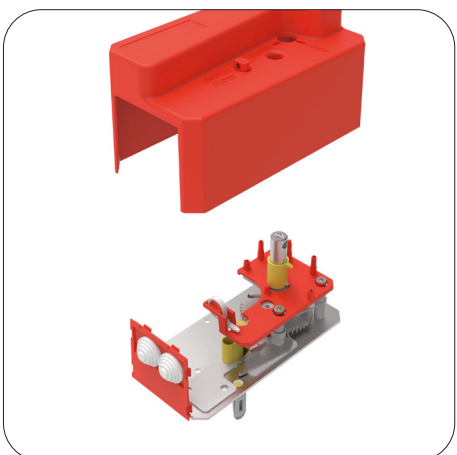

[Video instructions](#)

UPGRADE FROM MANUAL (R40-S) TO EMS

Before upgrade R40 to EMS, it is necessary to install kit for end contacts (FD-A-R40S-KIT).

Before upgrade R25/RS25-S to EMS, it is necessary to install R40 mechanism (FD-A-R40) and kit for end contacts (FD-A-R40S-KIT).

To upgrade to EMS you need to use the EMS kit!

Service work may only be performed by authorized persons!



1. Locate hex screw. Unscrew it and remove the cover.
2. Insert the EMS on the custom plate.
3. Screw the EMS to the plate and connect the 2-pin connector into the appropriate socket on the CEDC board.
4. Put the cover back in place.

Test the operation of the damper blade!

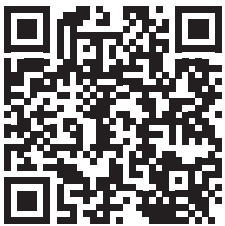

[Video instructions](#)

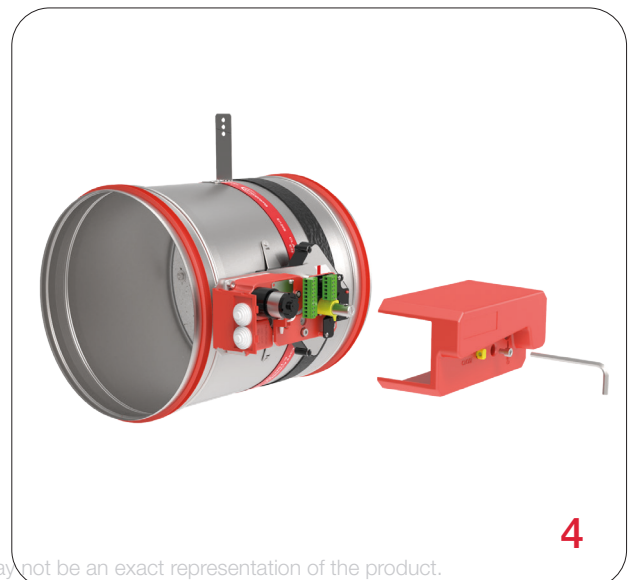
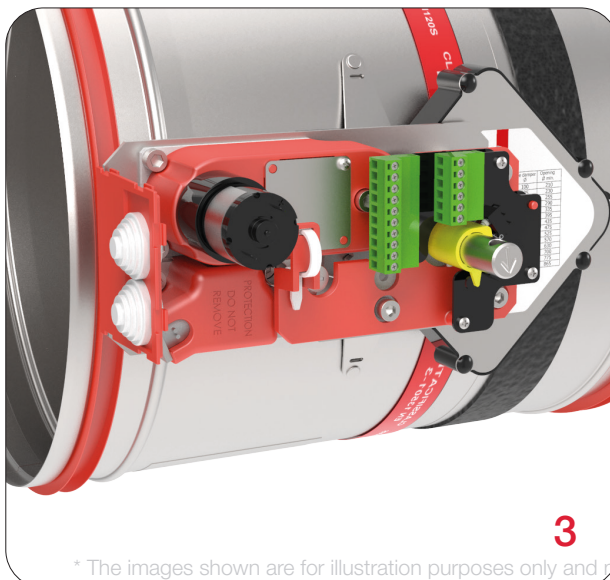
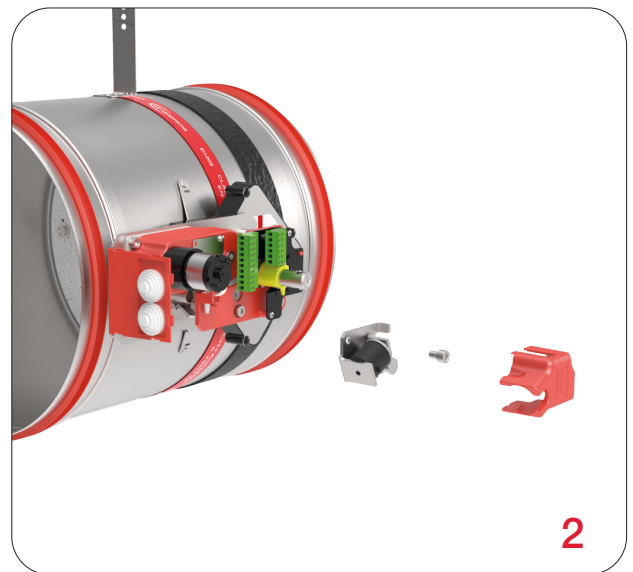
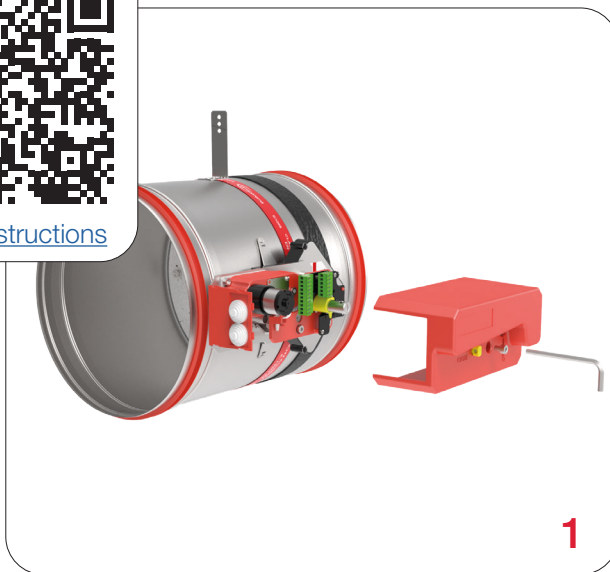

REPLACEMENT OF THERMAL FUSE (R25)



1. Find the hex screw located on the cover. Unscrew and remove the screw and the cover.
2. Find the hex screw on the thermal fuse and unscrew it.
3. Remove the old thermal fuse. Insert a new thermal fuse and screw it back on.
4. Put the cover back in place.

Test the operation of the damper blade!



[Video instructions](#)

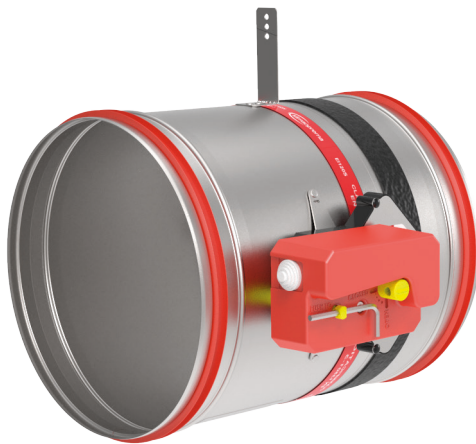

1

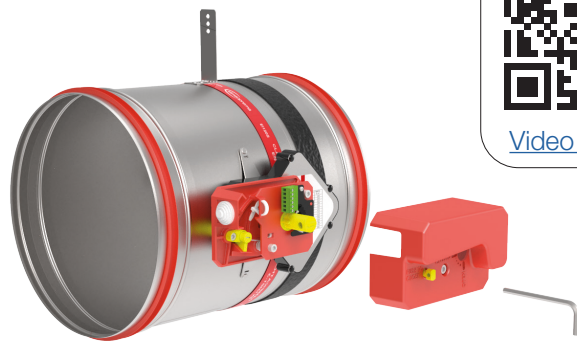

2

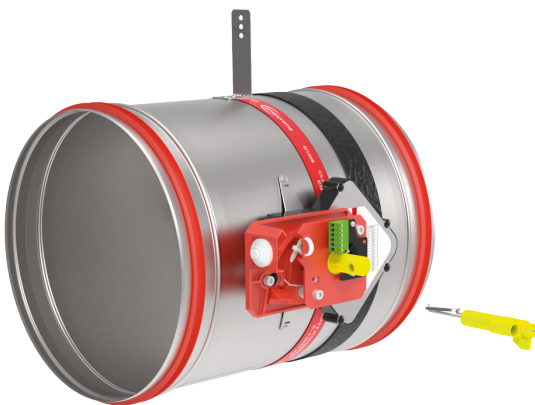

3

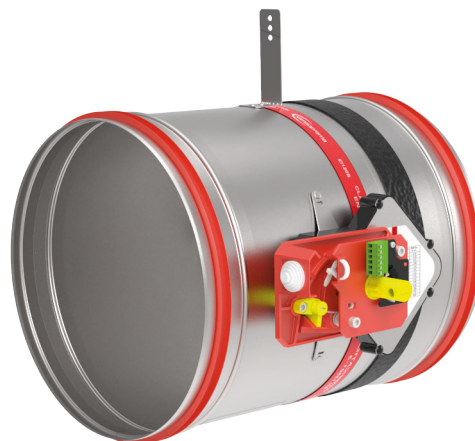

4

REPLACEMENT OF THERMAL FUSE (R40)

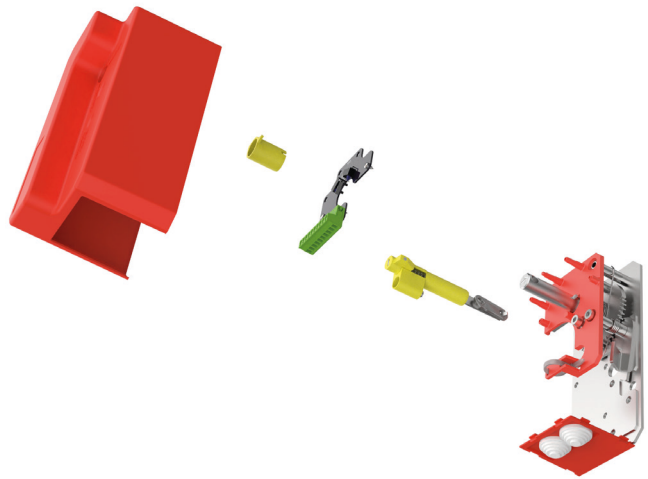

1. Find the hex screw located on the cover, unscrew and remove the screw and the cover.
2. Remove the position indicator sleeve.
3. Locate the 3 hex screws. Unscrew them. Remove the CEDC board (if applicable).
4. Locate the screw on the thermal fuse. Unscrew it. Remove the old thermal fuse. Insert a new thermal fuse. Put the CEDC board and the cover back in place.

Test the operation of the damper blade!



[Video instructions](#)

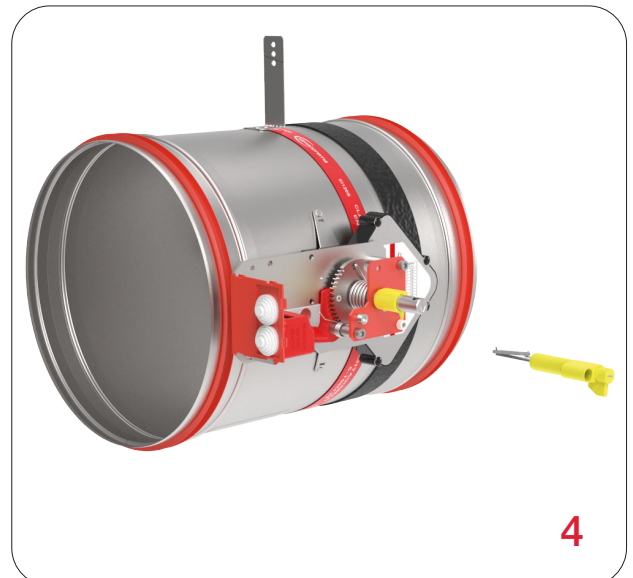
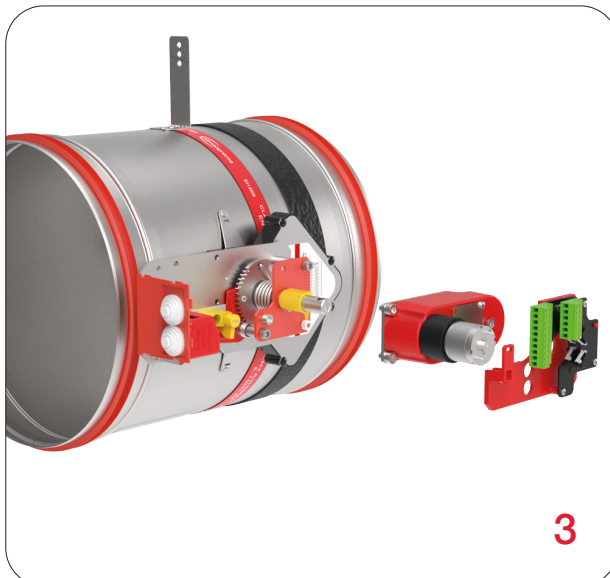
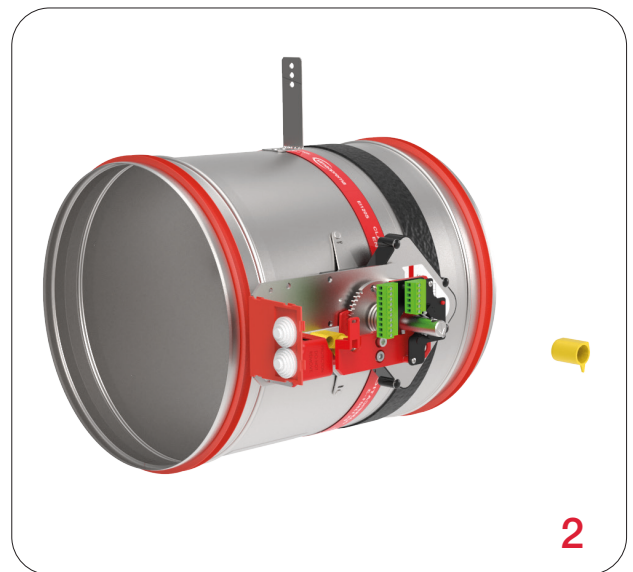
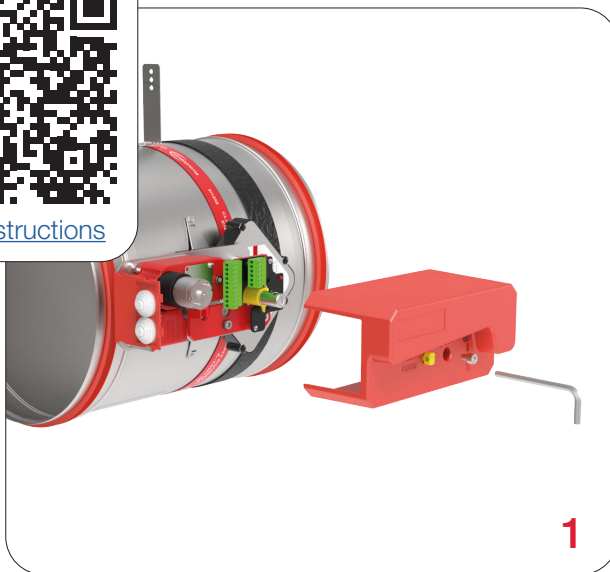

FIRE DAMPER TESTING

MANUAL ACTUATORS/ SOLENOID ACTUATOR

1. Close the damper blade by pushing the thermic actuator through the hole on the casing.

2. Open the damper blade by inserting the metal rod (i.e. screwdriver, hex wrench) max. 7 mm in diameter, into the yellow/ silver part and rotate the arrow to the open position.

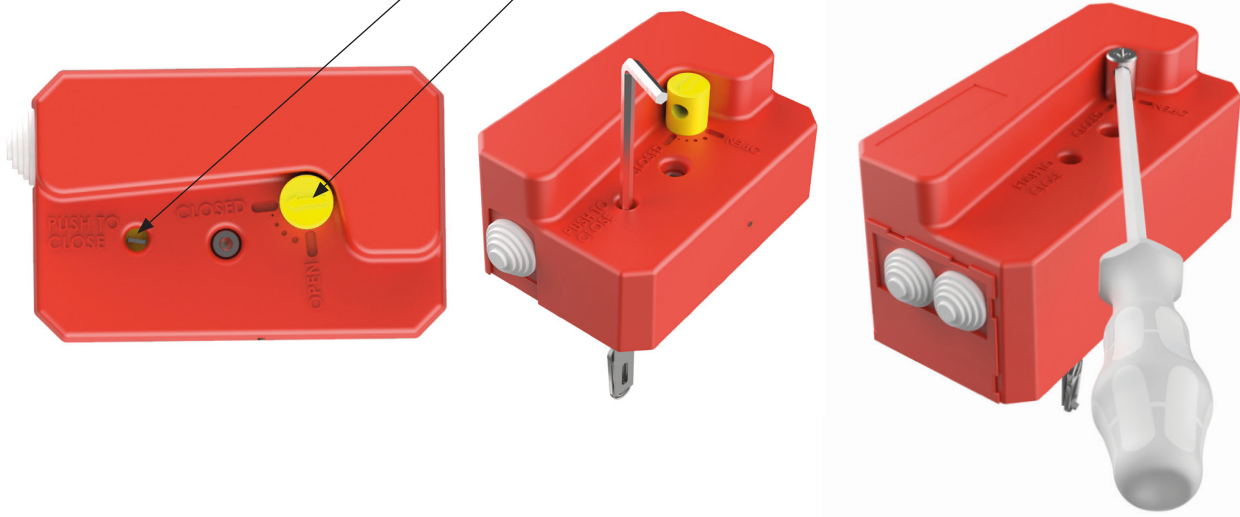

ELECTRIC ACTUATOR

1. Test the operation of the damper blade by pushing the test button.

2. Opening the damper blade:
Insert the handle provided with the Belimo actuator into the hole. Rotate it as shown on the actuator.



MAINTENANCE AND OPERATION

Fire dampers are designed with fully enclosed drive mechanism outside of the duct and as such do not require cleaning and regular maintenance.

However, fire dampers should be part of the routine cleaning and maintenance of the ventilation system.

Provide periodic inspection in accordance with the requirements of the law or by the building regulations or other local regulations.

In the absence of specific regulations, it is recommended to carry out the following control activities at intervals of no more than every 12 months:

Check access to the fire damper. Confirm that internal and external components of the fire damper are easily accessible.

Inspect the servomotor electrical wiring for any signs of damage (where applicable), check if the electrical terminals are tightened.

Inspect the end-switch wiring for damage (where applicable), check if the electrical terminals are tightened.

Check the fire damper for damage, examine the condition of the damper blades and seals, report if necessary.

Check the cleanliness of the damper and clean if necessary.

TRANSPORT

After arrival, check the fire damper for transport damage and shortcomings. In case of any damage or shortcomings, immediately contact your supplier.

STORAGE

If the damper is not installed immediately:

- Remove any wrapping.
- Protect fire damper from dust and contamination. Do not expose the fire damper to the effects of weather - store fire damper in a dry place.
- Do not store the unit below -20 °C or above 50 °C.

Please properly dispose of packaging material!

FUNCTIONAL TESTS

During normal operation, the damper blade remains open. The functional test consists of closing the damper blade and then reopening it.

According to EN 15650, a functional test should be performed at least every six months. If two tests in a row are successful, the next test can be performed a year later.

Verify correct manual opening and closing of the fire damper in accordance with the technical manual, testing procedure for different mechanisms is shown on a pg. 64.

Test the damper's opening and closing functions when controlled by the fire alarm system (if applicable)

Check the operation of the end switches in both open and closed positions, adjust and report as required

Ensure the damper performs its intended function as part of the control system (where applicable);

Confirm that the damper is returned to its normal operating position, typically the open position.

The functional test must be carried out in compliance with the basic maintenance principles of the European norms EN 13306, EN 15423 and EN15650.

COMMISSIONING

- 1) Carefully unpack FDC fire damper - be careful of sharp edges and do not use excessive force for unpacking
- 2) Inspect the fire damper - check the fire damper for damage
- 3) Installation of the fire damper - according to the installation instructions ([page 14.](#))
- 4) Before commissioning: check the fire damper functions



CLEANING

May be cleaned with a sponge, with water or a mild detergent. Take precaution if using disinfectant (disinfectant may contain alcohol which is flammable, take precaution to avoid ignition)

* The images shown are for illustration purposes only and may not be an exact representation of the product.





Images are for informational purposes only and may differ from the actual product.
Follow the latest versions of the catalog on the website.

 Gradna 78A, 10430 Samobor, Croatia
 +385 (0)1 33 62 513
 info@klimaoprema.com
 www.klimaoprema.com



www.hth.info

 Rehkamp 9, 30853 Langenhagen
 +49 511 / 726090-0
 hannover@hth.info